



OWNER'S MANUAL

Edition 5/June 2023



Silver Line S470N OWNER'S MANUAL



1. SAFETY INFORMATION	9
Introduction	9
Precautionary symbols.....	10
General information.....	12
Maximum number of persons	13
Maximum loading capacity	13
Engine information.....	14
Risk of flooding and stability	15
Bilge pumps and bailing.....	17
Stability and buoyancy.....	18
Risk of fire or explosion	20
Fire prevention	21
Battery.....	23
Fuel	24
Fire-fighting equipment	25
Electrical systems - Safety rules	26



TABLE OF CONTENTS

Engine starting	26
Man-overboard prevention and recovery	26
Means of reboarding	27
Danger from moving parts	27
Safety equipment.....	28
Safety driving rules	29
2. BOAT IDENTIFICATION	31
Boat's identification number	31
Builder's plate	32
3. BEFORE OPERATING YOUR CRAFT	34
Weather	34
Checklist before departure	34
Checking the boat and equipment	36
Rules to observe when afloat	37
4. OPERATING THE CRAFT	38
CL-14 steering console installation	39



CS-03 steering console installation.....	40
Container installation.....	41
Tube inflation	42
Overpressure valve (if fitted).....	49
Motor installation	50
Electrics	53
Navigation lights	59
Horn	59
Anchoring and mooring	61
Anchoring.....	61
Mooring	62
Towing.....	65
5. TECHNICAL INFORMATION	73
Technical specifications	73
Standard and optional equipment.....	75
Compartment chart	77
General arrangement of a boat S470N (S470NF)	78



TABLE OF CONTENTS

General arrangement of a boat S470NS (S470NSF)	79
General arrangement of a boat S470NL (S470NLF)	80
Steering console components	81
General view of a boat S470N	82
General view of a boat S470NS	83
General view of a boat S470NL	84
Loading passengers for S470NS (S470NSF)	85
Loading passengers for S470NL (S470NLF)	86
Electrical schematic diagram	87
6. SERVICE AND MAINTENANCE	89
Cleaning of tube	91
Plastic preservation	93
Cleaning	93
Salt removal	94
Polishing	94
Waxing	94
Cleaning of the underwater part of the hull from deposits.....	95



Upholstery care.....	96
Acrylic glass windshield care	97
Airtightness of the inflatable tube	98
Maintenance of stainless steel	100
Winterizing and storage.....	100
Regular inspections	101
7. TRAILERING.....	102
Lifting the boat	102
Boat towing.....	103
8. RESPECTING THE ENVIRONMENT	104
9. GRAND'S WARRANTY	105
Warranty period.....	105
Warranty coverage.....	106
Warranty exclusions	107
FOR YOUR NOTES.....	109



SAFETY

1. SAFETY INFORMATION

INTRODUCTION

Thank you for choosing a Grand boat.

If you need assistance or advice please contact your Grand Dealer or Distributor who has qualified specialists, special tools, original spare parts and accessories and will be happy to assist.

This Manual provides an overview for the safe operation of your Grand boat and *is not intended to teach you how to repair it*. Please take time to read it carefully so as to become familiar with your new boat. Make sure that you fully understand the controls and instructions before operating the boat. Improper operation can be extremely dangerous!

Please, note that most boating-related accidents happen when safety instructions are ignored. We want you to enjoy your experience on your boat so please be sure to take our guidance seriously and comply with safety instructions at all times.

The basic safety rules are stated throughout the Manual, additional precautions are indicated by the special PRECAUTIONARY SYMBOLS:



PRECAUTIONARY SYMBOLS

The following precautionary symbols are used throughout this Manual:



Indicates an imminently hazardous situation that, if not avoided, will result in death or serious injury. This signal word is to be limited to the most extreme situations.



Indicates a potentially hazardous situation that, if not avoided, could result in death or serious injury.



Indicates a potentially hazardous situation that, if not avoided, could result in minor or moderate injury.

Please note that in some countries a boat operating license or other form of authorization may be required.

We strongly recommend that your boat is inspected at least once a year by an authorized Grand agent.



SAFETY

Helmsmen should be familiar with the use of all safety equipment and emergency procedures (e.g. man overboard recovery, towing etc.). We strongly recommend that appropriate training is undertaken from a recognized boating and/or safety organization prior using your boat.

Please note that in some countries it is a mandatory requirement to wear a buoyancy aid.

Some information may not apply to your boat since standard and optional equipment may vary from model to model.

Data sheets and specifications given in this manual relate to the boat's characteristics at the time of publishing. Grand reserve the right to introduce changes in specifications and equipment without notice and without obligation.

We continually work with our customers to improve quality and to ensure you will be completely satisfied with your Grand boat.

If you have any additional questions after reading this manual, please feel free to ask for your dealer.

PLEASE KEEP THIS MANUAL IN A SECURE PLACE, AND HAND IT OVER TO THE NEW OWNER WHEN YOU SELL THE CRAFT.



GENERAL INFORMATION

Name of craft Manufacture: GRAND MARINE. Models: S470N, S470NF, S470NS, S470NSF, S470NL, S470NLF.

According to the Recreational Craft Directive 2013/53/EU of the European Parliament and of the Council of 20th November 2013, which is in force, your boat has design category: C, i.e., the craft is designed to operate in the following conditions:

Wind (Beaufort scale) up to and including Force 6.

Significant wave height ($H^{1/3}$, meters) up to and including 2 meters.

Explanatory note:

A watercraft given design category C is considered to be designed for a wind speed up to and including Force 6 and significant wave height up to and including 2 m.



WARNING

BE RESPONSIBLE, TAKE NOTICE OF THESE PARAMETERS WHEN YOU PLAN YOUR NAVIGATION PROGRAM AND DO NOT BOAT IF THE WIND/WAVE CONDITIONS ARE LIKELY TO EXCEED THESE PARAMETERS.



SAFETY

MAXIMUM NUMBER OF PERSONS

The Maximum number of people (adults + children) authorized to be on board according to design standards ISO 6185, ISO 14946 and ISO 12217 is given in the technical data sheet in the "TECHNICAL INFORMATION" section.



WARNING

DO NOT EXCEED THE MAXIMUM RECOMMENDED NUMBER OF PEOPLE. REGARDLESS OF THE NUMBER OF PEOPLE ON BOARD, THE TOTAL WEIGHT OF PEOPLE AND EQUIPMENT MUST NEVER EXCEED THE MAXIMUM RECOMMENDED LOAD. ALWAYS USE THE SEATS/SEATING SPACES PROVIDED.

MAXIMUM LOADING CAPACITY

You can find the maximum load capacity in the "TECHNICAL INFORMATION" section in this Manual. It is also shown on the manufacturer's plate affixed to the hull. Please note that the maximum load capacity includes the weight of all people onboard, outboard engine, provisions, personal effects, and additional equipment minus liquids in fixed tanks. Note that excess and unevenly distributed load within the boat can create unstable steering conditions and even loss of control.

**! WARNING**

WHEN LOADING THE CRAFT, NEVER EXCEED THE MAXIMUM RECOMMENDED LOAD. ALWAYS LOAD THE CRAFT CAREFULLY AND DISTRIBUTE LOADS APPROPRIATELY TO MAINTAIN DESIGN TRIM (APPROXIMATELY LEVEL). AVOID PLACING HEAVY WEIGHTS HIGH UP.

ENGINE INFORMATION

Information about recommended engine capacities, maximum engine capacities, maximum engine weights for each model are given in the technical data sheet of "TECHNICAL INFORMATION" section.

Please refer to the manual supplied by motor manufacturer before operating the motor and craft.



Routine maintenance should be carried out in strict conformity with the instructions given in the appropriate motor owner's manual.

! DANGER

NEVER USE A MOTOR WITH A POWER OUTPUT GREATER THAN THE MAXIMUM RECOMMENDED, OR HEAVIER THEN INDICATED ON THE MANUFACTURER'S PLATE. THIS COULD RESULT IN LOSS OF CONTROL.



SAFETY

RISK OF FLOODING AND STABILITY

HULL DRAINAGE



DANGER

NEVER OPEN THE HULL DRAIN PLUG WHEN AFLOAT.

To drain the hull, remove the plug (fig. 1).

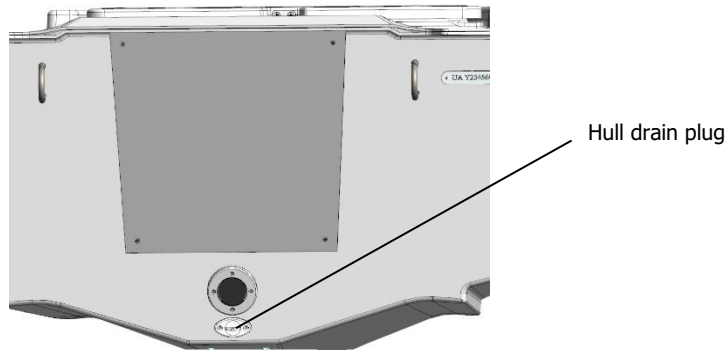

Fig. 1. The hull drain plug is located on the transom.

After removal refit and re-tighten (do not over-tighten) the plug before using the boat.

COCKPIT DRAINAGE

The boat is equipped with two cockpit drain plugs located at the transom.

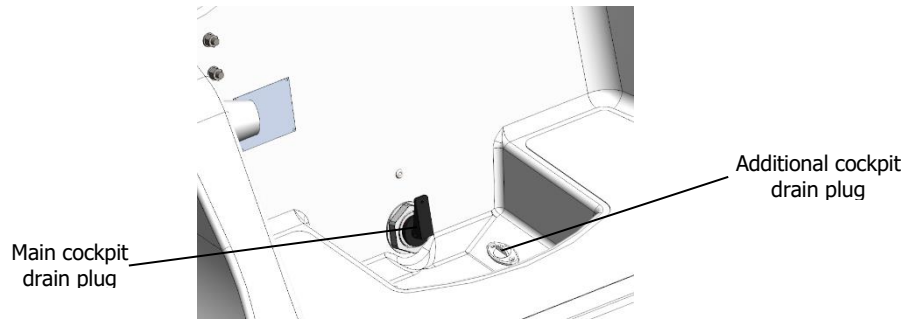

Fig. 2. Cockpit drain plugs.



WHEN THE BOAT IS ON LAND/DAVIT OR TRAILER, OPEN THE COCKPIT DRAIN PLUGS SO THAT WATER (RAINWATER, FOR INSTANCE) CAN EASILY DRAIN OUT OF THE BOAT AND NO DAMAGE TO THE INTERNAL COMPONENTS (E.G THE BATTERY) WILL OCCUR.



SAFETY

BILGE PUMPS AND BAILING

The craft is equipped with a bilge pump and drain pipe. To turn on/off the bilge pump use a switch located on the steering console.



WARNING

THE BILGE PUMP SYSTEM IS NOT DESIGNED FOR DAMAGE CONTROL.



CAUTION

CHECK BILGE PUMPS REGULARLY TO MAKE SURE THEY ARE WORKING. CLEAR DEBRIS FROM PUMP INLETS.



STABILITY AND BUOYANCY

The stability and buoyancy of the craft have been thoroughly assessed by the Manufacture in compliance with the requirements of the Recreational Craft Directive 2013/53/EU.

The craft manufacturer guarantees that the boat meets all safety criteria during normal operating conditions.

However, the person responsible for operating the craft must always keep in mind that the safety of the craft and crew should be their priority at all times and that conditions on the water can change suddenly with little prior notice.

Before using your boat, it is strongly recommended that appropriate training is given to all crew members in the safe operation of the craft.

IN CASE OF AN ACCIDENT, DO NOT PANIC AND REASSURE PASSENGERS

- Be aware that your boat, even if damaged, may provide the best shelter and facilitate your rescue. Never leave the boat whilst it remains afloat. Remember that an inflatable boat, even when full of water, is virtually unsinkable.
- If, after an accident, a tube compartment deflates, bring it inside the boat, restore the load balance to the opposite side of the deflated compartment and return to port at reduced speed.



SAFETY

- In case of a collision or an impact with a floating object, stop to examine the hull, the buoyancy tubes, the motor and its attachments and return to shore at a low speed.
- Signal for help.

Following an accident and before using the craft again, make sure that it is examined by your dealer or a qualified technician and any defects are repaired.



WARNING

NEGLECTING REGULAR INSPECTIONS AND REPAIRS MAY LEAD TO A SERIOUS INJURY OR DAMAGE AND WILL REDUCE THE LIFE OF YOUR BOAT.

For information concerning safe operation of the engine consult the manufacturers instruction manual.

Consult your Dealer for more detailed information on this subject before operating your boat.



RISK OF FIRE OR EXPLOSION

For information concerning safe operation of the engine consult the manufacturers instruction manual.

Consult your Dealer for more detailed information on this subject before operating your boat.



DANGER

AVOID CONTACT OF FLAMMABLE MATERIALS WITH HOT ENGINE PARTS.

Most fires are caused by electrical problems or careless fueling.

In case of fire, we recommend to stop the motor and turn off the battery switch.

Pay particular attention to the fact that a fuel tank and electrical devices are installed on your boat. This means that there is a risk of explosion or fire caused, for example, by a spark. Be careful and check systems regularly with a view to identifying leaks or corrosion in the fuel tank and possible damage to the electrical wiring.

For information concerning safe operation of the engine consult the manufacturers instruction manual.



FIRE PREVENTION

Consult your Dealer for more detailed information on this subject before operating your boat.

The owner/helmsman of the craft should:

- Inform all crew members about the location and operation of all firefighting equipment.
- Check firefighting equipment at the intervals indicated on each item.
- Replace any used extinguisher with one of same type and rating.



WARNING

NEVER MODIFY ANY OF THE CRAFT'S SYSTEM UNLESS COMPETENT TO DO SO.



DANGER

CHECK FOR FUEL AND GAS VAPOURS OR FUEL LEAKS AT REGULAR INTERVALS AND BEFORE STARTING THE ENGINE. NEVER USE A FLAME TO CHECK FOR LEAKS.



DANGER

DO NOT SMOKE OR USE AN OPEN FLAME WHEN FUELING THE BOAT.

** WARNING**

NEVER EXTINGUISH BURNING FUEL OR ELECTRICAL WIRING WITH WATER!

IF THE FIRE IS SMALL, TRY TO PUT IT OUT WITH A FIRE EXTINGUISHER OR BY THROWING A FIRE BLANKET OVER THE FLAMES.

IF THE FIRE OCCURS IN THE FUEL SYSTEM AND GETS OUT OF CONTROL AND CALL FOR HELP.

BEFORE ALL PASSENGERS ARE FORCED TO LEAVE THE BOAT, CHECK THAT EVERYONE IS WEARING A LIFEJACKET.

DUE TO THE FACT THAT BURNING FUEL MAY SPREAD OVER THE SURFACE OF THE WATER AND THE RISK OF EXPLOSION, TRY TO SWIM A SAFE DISTANCE AWAY FROM THE BOAT.



SAFETY

BATTERY



DANGER

1. AVOID SPARKS AND EXPOSED FLAMES NEAR BATTERY. IT MAY EXPLODE.
2. KEEP BATTERY TERMINALS PROTECTED SO AS TO AVOID A SHORT CIRCUIT OR CONTACT WITH ANY METAL OBJECTS.
3. TURN OFF THE ENGINE WHEN INSPECTING OR SERVICING THE BATTERY.
4. NEVER KEEP THE BATTERY CLOSE TO A FUEL TANK, FILLER OR FUEL SYSTEM COMPONENTS.

If you don't use the boat/battery for long time or during winter period, recharge the battery at least one a month to extend the battery life.

If an unsealed battery is used, take care to check periodically the electrolyte level.

Specific information about battery care could be found in its manual.

Don't forget to switch off the battery isolator switch if you no longer intend to use the boat.



FUEL



DANGER

EXPLOSIVE/FIRE HAZARD

IF A FUEL LEAK OR FUMES ARE DETECTED, DO NOT START THE ENGINE. ENSURE ALL CREW LEAVE THE BOAT AND HAVE A QUALIFIED PERSON REPAIR THE DEFECT AS SOON AS POSSIBLE. NEVER USE A FLAME TO CHECK FOR LEAKS.

HOSES SHOULD BE INSPECTED AT LEAST ANNUALLY AND REPLACED IF ANY DETERIORATION OR DAMAGE IS FOUND. IF FUEL LEAKAGE IS PRESENT, HAVE THE SYSTEM REPAIRED BEFORE FURTHER USE. FUEL SYSTEM REPAIRS SHOULD ONLY BE MADE BY COMPETENT PERSONNEL.

WHILE FUELING

- Keep hose nozzle in contact with the filler pipe to provide a ground against static sparks.
- Fill the tank slowly to avoid danger of spillage.
- Do not overfill the tank. Leave some room for the fuel to expand. In hot conditions fill the tank to about 80% of its maximum capacity.

If fuel is spilt on the hull, use an ordinary, non-abrasive cleaner then wipe with a damp cloth and rinse the area with clean water.



WARNING

NEVER FILL ANY FUEL TANK WHEN ENGINE IS RUNNING.



FIRE-FIGHTING EQUIPMENT

It is the owner/helmsman's responsibility to have an appropriate fire extinguisher in serviceable condition and readily accessible on board as prescribed by local requirements. At least one portable extinguisher type 34 B shall be present on board. The storage compartment of a portable fire extinguisher is marked by the symbol shown in Fig. 4.



Fig. 4. Symbol of designated place of portable fire extinguisher.

G380, when in service, shall be equipped with portable fire extinguisher of the following extinguishing capacities and in the following recommended location:

Nº1 Location: Bow locker Fire rating: 34B



WARNING

NEVER OBSTRUCT ACCESS TO PORTABLE EXTINGUISHER.



ELECTRICAL SYSTEMS - SAFETY RULES

- Check condition of battery and charging system before departure.
- Disconnect and remove the battery when the craft is in winter storage (cold weather areas) or long-term storage.

ENGINE STARTING

Refer to the engine manufacturer's manual for correct procedures before using the engine.



BE SURE THE ENGINE IS NOT IN GEAR BEFORE ATTEMPTING TO START IT!

MAN-OVERBOARD PREVENTION AND RECOVERY

Man-overboard prevention.

The working deck has an anti slip surface.

When the boat is underway, the helmsman and passengers should always occupy designated seating areas, using handles when necessary. Other parts such as seat backs, cleats, windscreen tops and rails can be used as handholds to reduce the risk of falling overboard.



WARNING

IF PASSENGERS ARE NOT IN DESIGNATED SEATING WHEN UNDERWAY THERE IS A RISK OF FALLING INSIDE THE BOAT OR OVERBOARD CAUSING SERIOUS INJUERY OR DEATH.

Areas such as the bow step plate, the engine well, tube step ends should not be used as seating when the boat is underway.

MEANS OF REBOARDING

Due to low freeboard, there are no specific devices to re-board.

When using safety handles caution must be paid to prevent the boat from capsizing. Make sure the engine switched off and propeller is not rotating.

DANGER FROM MOVING PARTS

Even in neutral, engine's propeller may rotate and may cause injury. If a person is in the water near the boat, immediately switch off the engine to avoid injury from the propeller rotation.



WARNING

KEEP AWAY FROM MOVING PROPELLER! IT COULD RESULT IN INJURY OR DEATH!



SAFETY EQUIPMENT

The owner/helmsman is responsible for ensuring that appropriate safety equipment is onboard and is in proper working condition. The type of safety equipment and quantity will depend on the conditions expected and length of trip.

The type of safety equipment required will depend on local or national regulations. In most countries, safety equipment of the following type is required:

- Emergency Engine Kill Switch Lanyard.
- Personal Flotation Devices (PFD).
- Horn or Whistle.
- A manual bailing device for removing water from the boat (bucket, hand pump).
- Visual Distress Signals.



CONSULT YOUR LOCAL DEALER REGARDING REQUIRED SAFETY EQUIPMENT IN YOUR COUNTRY/STATE BEFORE GOING AFLOAT.

Planning a trip, remember that not all fuel can be used from the fuel tank depending on the load and trim. About 20% can remain in the fuel tank.



SAFETY DRIVING RULES



WARNING

- DO NOT EXCEED THE AUTHORIZED NUMBER OF PERSONS OR MAXIMUM WEIGHT FOR THE CRAFT.
- MAKE SURE YOUR PASSENGERS REMAIN SEATED ON SEATS OR ON THE FLOOR. AVOID SITTING ON TUBES.
- AVOID BOW RIDING AS IT MAY BE ILLEGAL AND IS EXTREMELY DANGEROUS.
- DO NOT MAKE SHARP TURNS AT HIGH SPEEDS: YOU COULD BE EJECTED FROM THE BOAT.
- DO NOT MAKE VIOLENT CHANGES IN DIRECTION WITHOUT INFORMING PASSENGERS.
- A HELMSMAN OR A PERSON WHO KNOWS HOW TO STEER THE BOAT SHOULD ALWAYS REMAIN ON BOARD WHILE THE PASSENGERS ARE IN THE WATER EVEN IF THE BOAT IS ANCHORED.



CAUTION

THE OWNER IS RESPONSIBLE FOR ENSURING THAT THE NORMAL MODE OF OPERATION IS MAINTAINED. THIS MEANS THAT THE SPEED OF THE CRAFT NEEDS TO BE MATCHED TO THE PREVAILING SEA STATE, THE CRAFT BEING USED "WITH GOOD SEAMANSHIP BEHAVIOUR".

 **WARNING**

More the speed is higher, more risks are involved.

If you are not an experienced driver, we recommend not to exceed 30 knots.

Be realistic about your capabilities.

THE BOAT IS DESIGNED FOR RECREATIONAL PURPOSES ONLY, NOT FOR COMPETITIONS.

Please remember also that the is not designed to jump through the waves. The builder is not responsible for any damage from excessive loads resulting in neglect of the precautions outlined in this manual.



BOAT IDENTIFICATION

2. BOAT IDENTIFICATION

BOAT'S IDENTIFICATION NUMBER

Every boat has "Watercraft Identification Number" (WIN), which uniquely identifies your boat and is important for safety and identification purposes. The WIN is marked on a non-removable metal plate, which is fixed to the transom area of your boat (fig. 3).

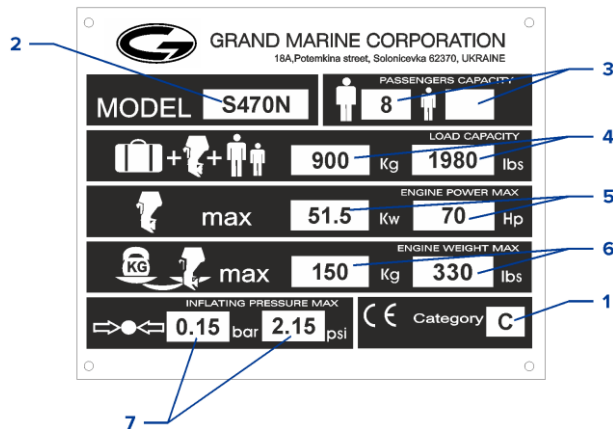

Fig. 3. Location of the WIN plate.



BUILDER'S PLATE

The builder's plate (fig. 4), which is fixed to the craft, provides information about the Builder including builder's name, registered trade or trade mark plus contact name and address, CE marking, craft design category, maximum recommended load minus liquids in fixed tanks, number of persons recommended by the builder for which the craft was designed. This information may not however comprise a complete list: safety requirements (obligatory safety equipment carried on the boat, maximum authorized distance you can navigate from a port, etc.) may vary according to the country or state.



- 1 - Design category*
- 2 - MODEL: Catalogue name or model number.
- 3 - Maximum number of people authorized on board (adults + children) according to ISO standards.
- 4 - Maximum load capacity of the boat allowed by the builder and expressed in kilograms and lbs.
- 5 - Maximum outboard power allowed by the builder for the boat and expressed in kilowatts and HP.
- 6 - Maximum weight of outboard motor allowed by the builder expressed in kilograms and lbs.
- 7 - Nominal Pressure of the buoyancy tubes in Bar and Psi.

Fig. 4. Builder's plate.



BOAT IDENTIFICATION

Always refer to local regulations for information on additional requirements.

*Design category (European Directive 2013/53/EU):

Category	C	D
Navigation	"Inshore"	"Protected water"
Wind speed (Beaufort scale)	Up to and including F6	Up to and including F4
Significant height of wave to consider (in meters)	Up to and including 2m	Up to and including 0.3m



BE RESPONSIBLE, TAKE NOTE AND DO NOT NAVIGATE IF THE CONDITIONS ARE LIKELY TO EXCEED THESE PARAMETERS.



3. BEFORE OPERATING YOUR CRAFT

WEATHER

Before starting any trip, check the local weather forecast. Depending on location and seasonal conditions, the weather can sometimes change very quickly. If the weather suddenly changes and conditions become rough:

- Try to find shelter as soon as possible because riding out a storm at sea can be extremely dangerous.
- Reduce speed whilst maintaining sufficient power to continue making headway.
- Check that all passengers have personal flotation devices and are sitting close to the boat's centerline.

CHECKLIST BEFORE DEPARTURE



MAKE SURE YOU HAVE ALL NECESSARY INFORMATION AND PASSENGERS ARE INFORMED.



BEFORE OPERATING YOUR CRAFT

GENERAL

1. OBTAIN INFORMATION on local regulations and hazards related to marine activities and boat operation.
2. CHECK weather forecast, local currents, tides and wind conditions.
3. ADVISE someone on land when you expect to be back.
4. EXPLAIN basic boat operation to all passengers.
5. ENSURE that at least one passenger is able to operate the craft and motor, provide training as needed.
6. FAMILIARISE all passengers with safety procedures and drills.
7. LEARN how to estimate the distance you can cover with a full tank of fuel. Always be sure you have enough fuel to reach your destination or a place of safety.
8. CHECK you have all necessary documentation and licenses.



WARNING

CHECK THAT THE BOAT AND ALL EQUIPMENT ARE IN GOOD WORKING ORDER.



CHECKING THE BOAT AND EQUIPMENT

- Using a pressure gauge (not supplied), check inflation pressure in each section of the tube.
- Check the tightness of the outboard motor clamps or bolts.
- Inspect the steering system: an improperly maintained system may fail, causing sudden loss of control.
- Remove the cockpit and hull drain plugs, check the gaskets, replace if necessary.
- Check the fuel system.
- Top off fuel and lubricating oil levels to required levels. Note: do not overfill fuel tank.
- Be sure that you do not exceed the recommended maximum load indicated on the Builder's plate. Check the load is evenly distributed.
- Make sure that each passenger is seated or has a seat available. Inform all passengers regarding the necessity to hold on to safety handles. Check that each passenger has his personal flotation device.
- Check that all required safety equipment is on board (horn, first aid kit, waterproof light, cell phone in watertight case, fresh water reserve etc.).
- Check that the boat is equipped with an additional flotation device for emergency use.
- Check that the boat is equipped with two oars/paddles. Check the condition of the oars and rowlocks.
- Be sure that the boat is equipped with at minimum 2 x boat length of suitable towing line.



BEFORE OPERATING YOUR CRAFT

RULES TO OBSERVE WHEN AFLOAT

- Be responsible: do not ignore safety rules.
- Make sure that you are always in control of your boat.
- Always operate your boat with courtesy and respect for others.
- Respect local regulations and practices.
- Near the shore, navigate within designated boating areas.
- Always be sure that you can reach shelter quickly.



DANGER

1. WEAR PERSONAL FLOTATION DEVICE (PFD)
2. ALWAYS USE THE ENGINE KILL SWITCH LANYARD: WEAR IT AROUND YOUR WRIST, ANKLE, OR AFFIX TO YOUR CLOTHES.



4. OPERATING THE CRAFT

WINDSCREEN INSTALLATION

In order to install the windscreen onto the console perform the next operations (fig. 5):

- Unfix and hinge out overhead part of steering console or seat for steering console CS-03 «Sport».
- Align holes in the windscreen with holes in the console overhead part.
- Fix windscreen by means of the screws M6x25, bushes, washers and nuts M6 from the complete set.

For steering console CS-03 «Sport»:

- Align holes in the windscreen railing with holes in the console «Sport».
- Fix windscreen railing by means of the bolts M8x20, support windscreen railing and washers from the complete set. Tighten all the bolts and screws.

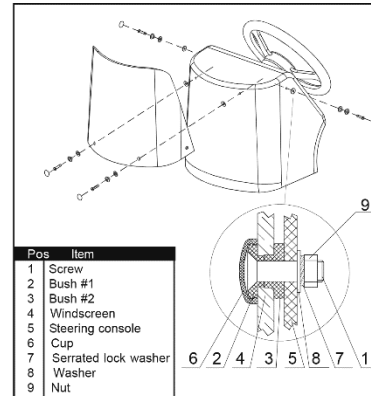

Fig. 5. Installation of windscreen.



OPERATING THE CRAFT

CL-14 STEERING CONSOLE INSTALLATION

- Align holes on the bottom of steering console CL-14 with holes on the deck.
- Fix steering console to the deck by means of bolts M8*25 and toothed lock washer (see fig. 6).
- Attach steering system cable in accordance with its own installation (manual).
- Replace and fix overhead part of the steering console by means of washers and nuts M8 from complete set.
- Tighten all the bolts and nuts.

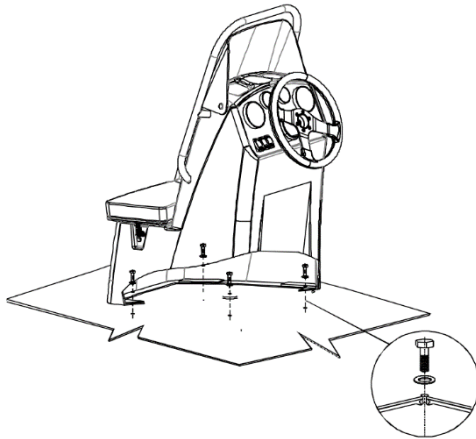

Fig. 6. Installation of steering console CL-14.

CAUTION

TO AVOID THE WATER PENETRATION INTO THE CONSOLE AND HULL INNER LAYERS, PLEASE, TIGHT ALL THE HOLE FREE SPACE WITH ANY WATER-RESISTANT FILLER.

ALL BOLTS, SCREWS AND NUTS SHOULD BE CHECKED FROM TIME TO TIME TO MAKE SURE THEY ARE TIGHT.

FOR MORE INFORMATION, PLEASE CONTACT YOUR LOCAL GRAND AUTHORIZED DEALER.



CS-03 STEERING CONSOLE INSTALLATION

- Align holes on the bottom of steering console with holes on the deck.
- Fix steering console to the deck by means of bolts M8*25 and toothed lock washer (see fig. 7).
- Attach steering system cable in accordance with its own installation (manual).
- Replace and fix overhead part of the steering console by means of washers and nuts M8 from complete set.
- Tighten all the bolts and nuts.



Fig. 7. Installation of steering console CS-03.

CAUTION

TO AVOID THE WATER PENETRATION INTO THE CONSOLE AND HULL INNER LAYERS, PLEASE, TIGHT ALL THE HOLE FREE SPACE WITH ANY WATER-RESISTANT FILLER.

ALL BOLTS, SCREWS AND NUTS SHOULD BE CHECKED FROM TIME TO TIME TO MAKE SURE THEY ARE TIGHT.

FOR MORE INFORMATION, PLEASE CONTACT YOUR LOCAL GRAND AUTHORIZED DEALER.



OPERATING THE CRAFT

CONTAINER INSTALLATION

- Hinge out the seat.
- Align holes on the bottom container with holes on the deck.
- Fix container to the deck by means of bolts M8*25 and toothed lock washer (see fig. 8).
- Tighten all the bolts.
- Replace the seat.

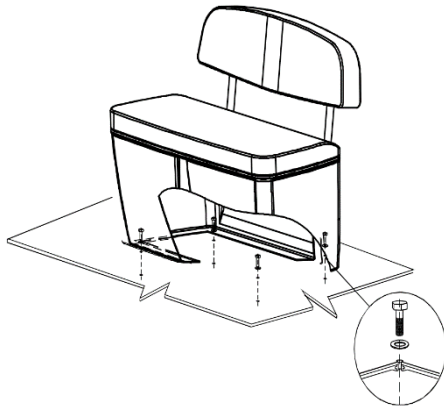

Fig. 8. Installation of container.

CAUTION

TO AVOID THE WATER PENETRATION INTO THE CONSOLE AND HULL INNER LAYERS, PLEASE, TIGHT ALL THE HOLE FREE SPACE WITH ANY WATER-RESISTANT FILLER.

ALL BOLTS, SCREWS AND NUTS SHOULD BE CHECKED FROM TIME TO TIME TO MAKE SURE THEY ARE TIGHT.

FOR MORE INFORMATION, PLEASE CONTACT YOUR LOCAL GRAND AUTHORIZED DEALER.



TUBE INFLATION

Inflation valve. Option 1.

If the boat is equipped with a valve as shown in figure 9, follow the instructions below.

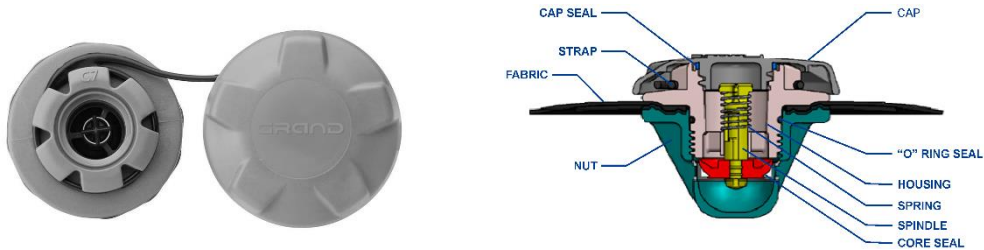

Fig 9. Inflation valve (option 1).

To inflate the tube chamber, first open the valve cap by turning it about half a turn counter clockwise (fig. 10). The spindle should be in the upper (closed) position.

“O” ring and cap seals of the valve can wear out overtime and can be subject to change.



OPERATING THE CRAFT

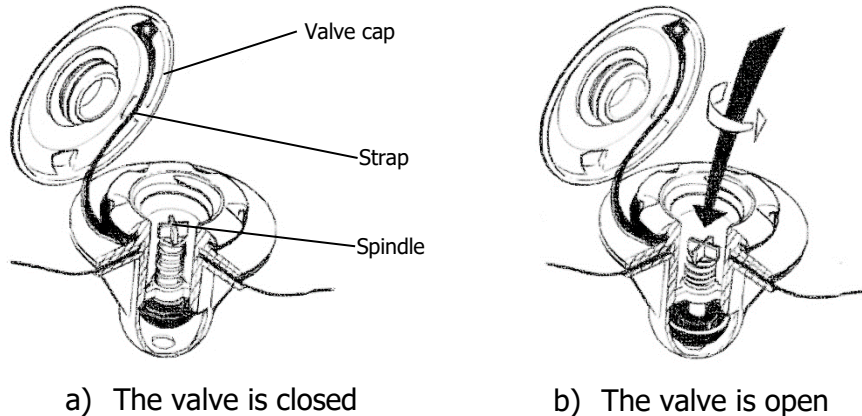

Fig. 10. Design of the inflation valve.

When the spindle is in the normal (closed) position, the valve operates as a check valve and opens when air is pumped into the tube.

To release air from the tube, press down and hold the spindle. If you need to fully deflate the tube, press and turn the spindle counter clockwise to lock it in the "open" position.

In order to quickly and completely deflate the tube we recommend to use a supplied pump.



To inflate the tube chambers, use the foot pump (fig.11) supplied.



Fig. 11. Foot pump.

Insert the end of the hose into the inflation valve using one of the appropriate adapters.

Make sure the adaptor makes an air-tight connection with the valve and inflate using foot pump.



OPERATING THE CRAFT

Inflation valve. Option 2

If the boat is equipped with a valve as shown in figure 12, follow the instructions below.

To open the valve cap turn it a quarter counter clockwise. The plunger should be in the upper (closed) position.



Fig. 12. Inflation valve (option 2).



To inflate the boat connect the special "bayonet" type adaptor into the valve and secure it by twisting a quarter turn clockwise. Use the foot pump (fig. 11) supplied to inflate the tube. To remove the adaptor turn it a quarter turn counter clockwise.

To release the air from the tube chamber, depress the plunger. To fully deflate the tube chamber fully depress and then release the plunger, so that it locks in the lower "open" position.

To inflate the tube, you can also use a small electric boat pump.



CAUTION

IF YOU USE A SMALL ELECTRIC PUMP, COMPLETE THE PROCEDURE BY USING THE FOOT PUMP TO REACH THE REQUIRED NOMINAL PRESSURE.

Begin the inflation procedure according to the sequence shown in figure 13. Initially, partially inflate each chamber (approx. 0.1 bar (1.45 psi)) then repeat the procedure inflating each chamber to its nominal pressure, 0.15 bar (2.15 psi).



OPERATING THE CRAFT

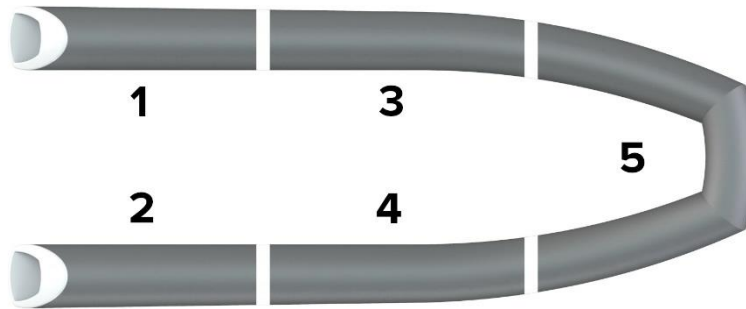

The drop of pressure up to 20 mbar is normal after the boat has been put on the water the due to the difference between air and water temperature.

Fig. 13. Tube inflation sequence.

Check the pressure in each chamber with a pressure gauge. If you do not have a pressure gauge the following procedure will serve as a guide. Press a finger firmly against the tube – if the tube is depressed by about 10 mm ($\frac{3}{8}$ inch) this indicates that the pressure is approximately correct.

After the tube chambers have been inflated to the nominal pressure place the valve caps back (valve options 1 and 2). Fit the caps to the valve body and turn clockwise until secure. Valve caps protect the valves from accidental opening, provide a secondary seal and protect the valves from contamination.

The valves require little maintenance. Keep them clean using a standard household cleaner.



Remember that changes in ambient temperature will change the inflation pressure within the tube *especially in tropic areas*. If there is no overpressure valve, a tube that was inflated to or above its nominal pressure in the morning can be loaded beyond its design pressure and be damaged by a significant pressure increase resulting from the thermal expansion of the gasses due to increase in temperature in the afternoon.

WARNING

IF THE PRESSURE WITHIN THE TUBE BECOMES EXCESSIVE, THE GLUED JOINTS MAY BE DAMAGED.

If the ambient temperature rises significantly or you intend leaving the boat in direct sunlight, we recommend you relieve the air pressure in each chamber. It is strongly recommended that the boat be kept in the shade or under cover when not in use.

CAUTION

DO NOT USE SOURCES OF HIGH-PRESSURE COMPRESSED AIR FOR INFLATING THE TUBE. EXCESSIVE PRESSURE CAN DAMAGE THE GLUE JOINTS AND THE INTERNAL WALLS.



OPERATING THE CRAFT

OVERPRESSURE VALVE (IF FITTED)

Overpressure valves can be fitted to buoyancy tubes as shown in figure 14.

It serves to protect the tube from over inflation and excess pressure build up due to solar heat.



Without strainer



With strainer

Fig. 14. Overpressure valve.

Ultrafine mesh of the filter cup prevents contamination without affecting the pressure relief function. The filter cap can be easily removed for cleaning.



MOTOR INSTALLATION

Information about motor trim is given for reference purposes only.

The engine manufacturer's dealer or authorized agent should undertake installation of the motor on your boat.



Please refer to the manual supplied by motor manufacturer before operating the motor and craft.

The optimum position is with the propeller axis parallel with the water.

CORRECT



Fig. 15. Optimum trim.



OPERATING THE CRAFT

If the motor is tilted too far outwards from the transom, the boat will tend to porpoise.

INCORRECT



Fig. 16. Trim up.

If the motor is tilted too far inwards towards the transom the boat will travel bow down.

INCORRECT



Fig. 17. Trim down.



ENGINE KILL SWITCH LANYARD

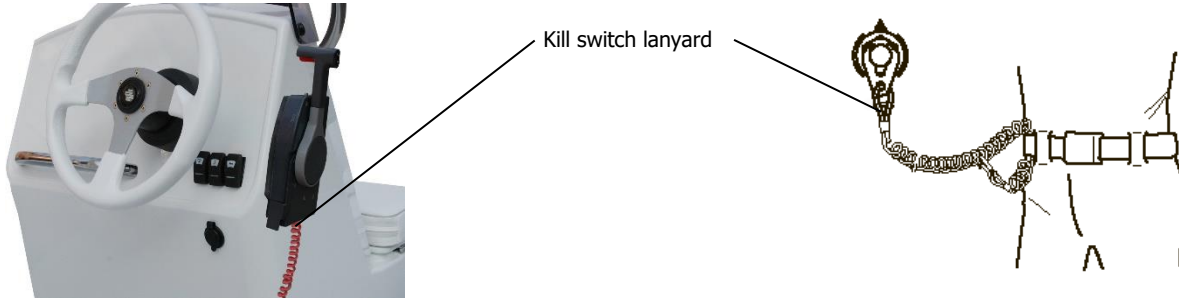

Fig. 18. Engine kill switch lanyard.

For safety reasons always use the engine kill switch lanyard.

The purpose of the engine kill switch lanyard is to turn off the engine if for any reason the helmsman is removed from the steering position.



DANGER

WHEN THE ENGINE IS RUNNING, THE KILL SWITCH LANYARD SHOULD ALWAYS BE WORN ON THE WRIST, ANKLE, OR FIXED TO YOUR CLOTHES OR TO YOUR PERSONAL FLOTATION DEVICE. IGNORING THIS INSTRUCTION MAY CAUSE DEATH OR SERIOUS INJURY.



OPERATING THE CRAFT

ELECTRICS

System voltage – 12V, two-wire d.c. system with negative ground (earth). Connection is done through a motor.

BATTERY ISOLATOR SWITCH

The battery isolator switch is designed to isolate the battery from the boat's electrical circuit.

It is used when the boat is in long-term storage to prevent the battery becoming drained, during maintenance (this should be done by qualified electrical technician. See also "ELECTRICAL SYSTEMS" in the section "SAFETY") and in emergency cases.

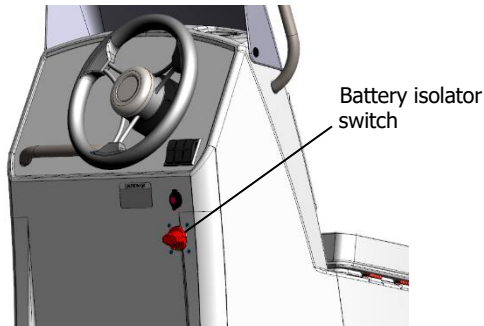

Fig. 19. Battery isolator switch.

Specification:

Operating voltage: up to 48 Volt DC.

Nominal current: 250 A.

Max. current: 450 A - 5 min / 700 A - 10 sec.

The battery isolator switch is located on the right side of steering console in an accessible place for the helmsman. It should be accessible at all times for disconnecting all devices from the battery.

The battery must NEVER be disconnected from the engine when it is running!



SWITCH PANEL

Use the following switches located on the steering console to switch on/off a horn, navigation lights and bilge pump.

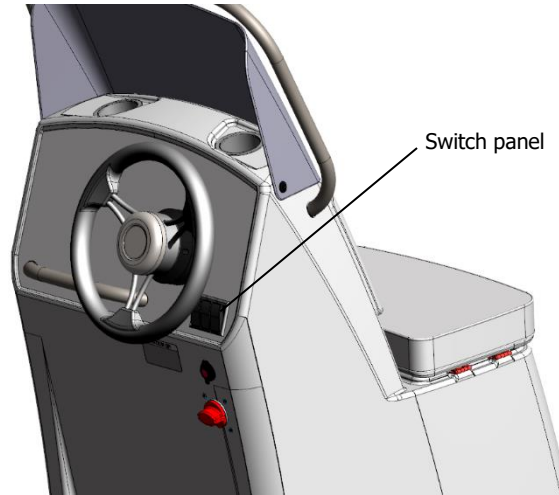
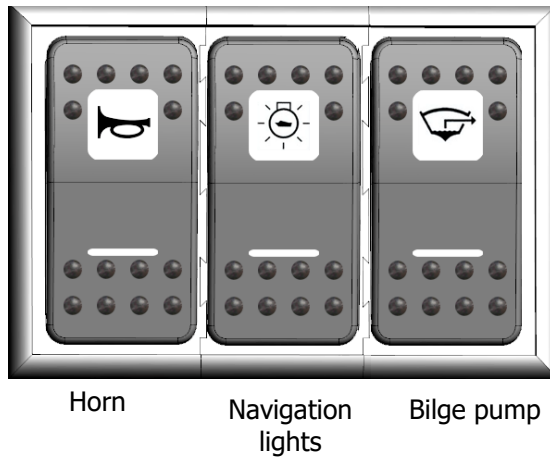

Fig. 20. Switch panel.



OPERATING THE CRAFT

LOCATION OF FUSE BOX IN CL-14 STEERING CONSOLE

If the boat is equipped with CL-14 steering console, the fuse box is located on the right inboard side of steering console, under a seat. To get access to the fuse box, open the seat.

To change a fuse, unlock and open fuse box transparent cover. Pull out a blown fuse and replace it with a new one. Place the fuse box cover back. A rating of relevant fuses are given below.

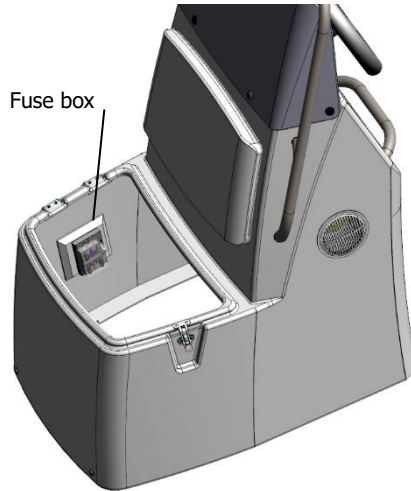

Circuit	Fuse rating, A
Horn	5
Navigation lights	5
Bilge pump	3
USB socket	2

Fig. 21. CL-14. Fuse box location.



LOCATION OF FUSE BOX IN CS-03 STEERING CONSOLE

If the boat is equipped with CS-03 steering console, the fuse box is located on the left inboard side of steering console, under a seat. To get access to the fuse box, open the lock and remove the seat.

To change a fuse, unlock and open fuse box transparent cover. Pull out a blown fuse and replace it with a new one. Place the fuse box cover back. A rating of relevant fuses are given below.

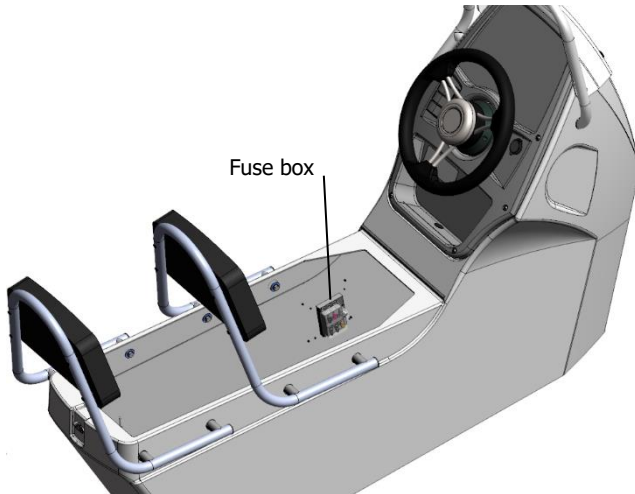

Circuit	Fuse rating, A
Horn	5
Navigation lights	5
Bilge pump	3
USB socket	2

Fig. 22. CS-03. Fuse box location.



OPERATING THE CRAFT

BILGE PUMP

The bilge pump serves to pump water out of the bilge area of the boat.



The bilge pump is located in the drain well.

Pump specifications:

Capacity 1.9 m³/h (with zero head).

Power 12 V/1.6 A.

Maximum head 3 m.

Connection 3/4".

Fig. 23. Bilge pump.

Switching the bilge pump on and off is done manually by using the switch located on the steering console.

Check the operation of the bilge pump by using the switch located on the steering console. Make sure the inlet channels are free from contamination.



FOLDING NAVIGATION ARCH (IF APPLICABLE)

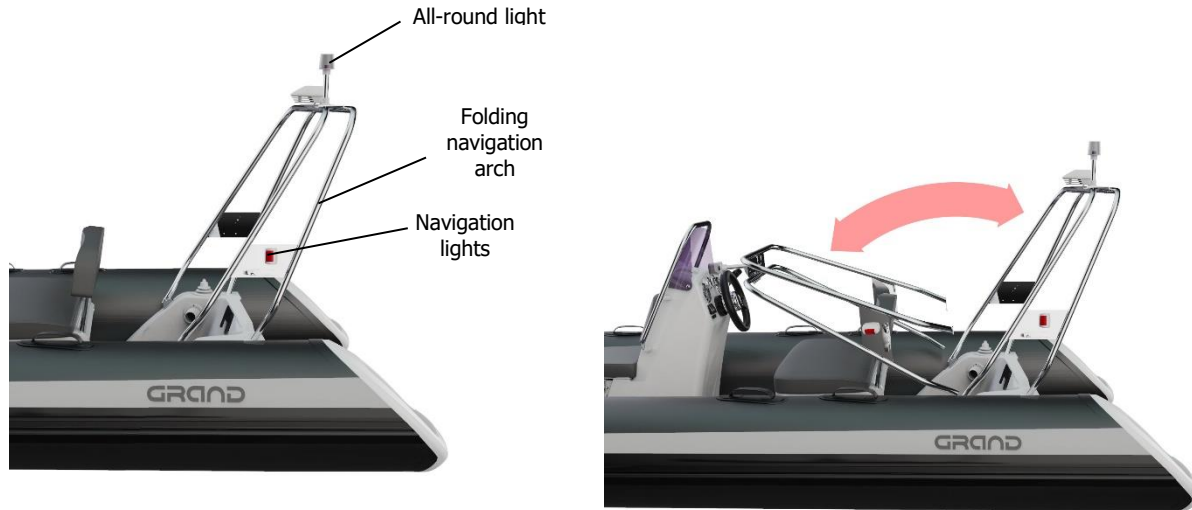

Fig. 24. Folding navigation arch.

Navigation arch is equipped with side navigation lights and all-round light. If needed navigation arch can be easily stored. See the description of above element on the next page.



OPERATING THE CRAFT

NAVIGATION LIGHTS

Navigation lights are designed to indicate the craft's relative position, the nature of its movement or its location at night. The side lights are a green light on the starboard side and a red light on the port side.

Use the switch on the steering console to turn the navigation lights on and off when needed.

HORN

The horn is mounted on the steering console.

The horn serves as a warning to other craft and individuals when setting off, mooring or in other safety related situations.

The horn is switched on/off by means of a switch located on the steering console. To use the horn press and hold the switch. Release the switch to turn the horn off.

Before making a trip, check the horn is functioning by briefly switching it on and off.



LIFTING EYES

The boat is fitted with lifting eyes at the bow and rear (fig. 25, 26). Use these eyes to lift the boat.

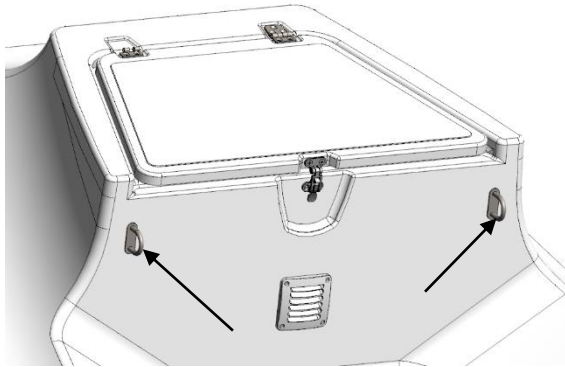

Fig. 25. Bow lifting eyes, 2 positions.

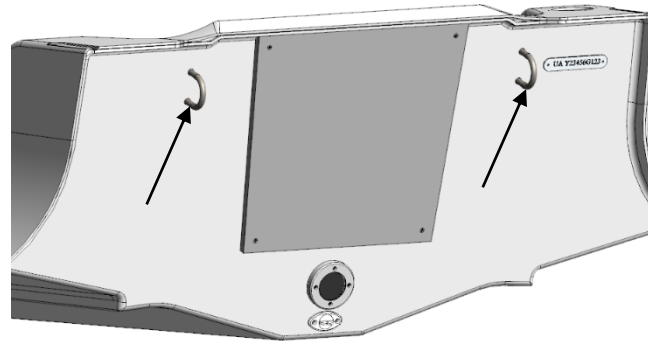

Fig. 26. Rear lifting eyes, 2 positions.



OPERATING THE CRAFT

ANCHORING AND MOORING

ANCHORING

Please make sure your craft is equipped with an appropriate anchor and line. If you are not sure, ask your Dealer who will be happy to advise. Setting-up a secure anchorage requires knowledge and practice so it is important that properly trained persons undertake this procedure.

When anchoring your boat make sure that you will not create a potentially dangerous situation for yourself, other boats or people.



WARNING

**ANCHOR ONLY IN AREAS WHERE YOUR BOAT WILL NOT HINDER OTHER BOATS.
DO NOT ANCHOR IN A CHANNEL!**

Before anchoring the boat, stop the engine. When anchoring be aware that the condition of the sea bed, changes in tide, wind strength and direction and currents will affect the position of the craft. Use local landmarks to obtain an approximate fix for the craft's position and check this regularly.



MOORING

Use the bow towing eye and rear lifting eyes for mooring.

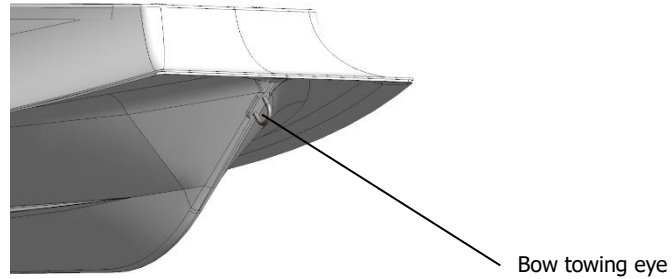

Fig. 27. Bow towing eye.

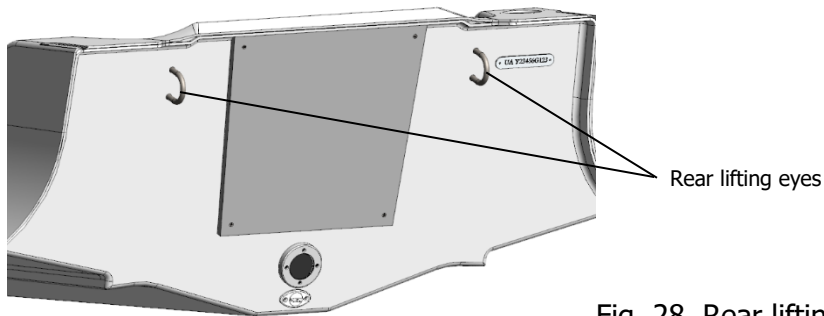

Fig. 28. Rear lifting eyes.



OPERATING THE CRAFT

When the boat is moored or parked the cockpit drain plug should remain open. This will ensure rain water does not accumulate in the boat.

Breaking strength, kN	
Bow eye	12.5
Rear eye	8.7



CAUTION

THE BREAKING STRENGTH OF LINES SHALL IN GENERAL NOT EXCEED 80% OF THE BREAKING STRENGTH OF THE RESPECTIVE STRONG POINT.



CAUTION

BE VERY CAREFUL WHEN MOORING: ARMS AND LEGS MAY BE INJURED IF THEY ARE OUTSIDE THE BOAT.

DON'T USE SAFETY HANDS, RAILS, HANDRAILS, STEERING WHEEL FOR MOORING.



BEACHING, LAUNCHING AND RECOVERING THE BOAT FROM THE WATER

When approaching a beach or waters edge proceed slowly and with extreme caution.

Avoid hazards below the water surface such as rocks. Hazards can damage the hull, tube, motor, or propeller. Do not power the boat onto land as serious damage to the hull and tube may result.

Do not drag the boat across rough or abrasive surfaces (rocks, concrete etc.). The hull and tube can be damaged.



NEVER DRAG THE BOAT OVER A ROUGH SURFACE (ROCKS, STONES, CONCRETE, ETC) AS THE HULL AND TUBE CAN EASILY BE DAMAGED.

Regularly check the surface of the fiberglass hull. If the gel coat is damaged, contact your Dealer for repair.



OPERATING THE CRAFT

TOWING

When towing an inflatable boat behind another craft, always connect the tow line only to the towing eyes. It's forbidden to use handles, railings, cleats or other equipment which is not designated for towing. If possible use a double tow line when towing behind another boat. The second line acts as a backup in case one line breaks or comes undone.

Use a tow line of sufficient length so that there is at least two boat lengths between boats.

Use only line intended for towing, ask your Dealer for advice and select the correct line for your application (Do not tow with three strand nylon rope).

A towed boat should always be observed. A boat which is used as a tender is not designed to be towed all the time and over long distances. The tender, when is not in operation, should be placed and secured on the main boat (yacht).

Do not use a tow line with signs of damage or wear. Check tow lines for wear and damage prior to use.

Always keep hands and feet clear of tow lines.

Be prepared to cast loose or cut the tow line if necessary.

Towing should be done at low speed.



TOWING MUST BE DONE AT LOW SPEED (NOT MORE THAN 10 KM/H) AND IN GOOD WEATER CONDITIONS WITH NO WAVES. THE BOAT BEING TOWED MUST BE OBSERVED AT ALL TIMES.



TOWING EYE

The towing eye is located at the bow.

Breaking strength of bow towing eye is 12.5 kN.

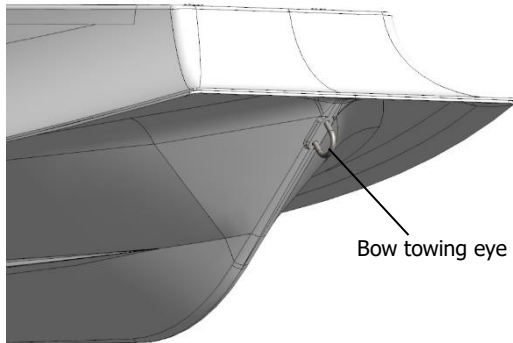

Fig. 29. Bow towing eye.

CAUTION

THE BREAKING STRENGTH OF LINES SHALL IN GENERAL NOT EXCEED 80% OF THE BREAKING STRENGTH OF THE BOW TOWING EYE



OPERATING THE CRAFT

BOW LOCKER



Fig. 30. Bow locker.

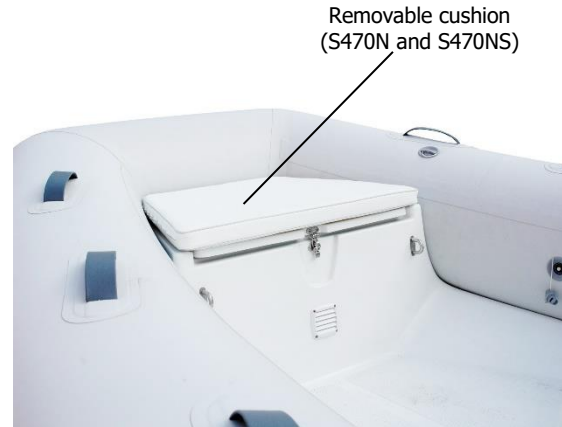

Fig. 31. Removable cushion.

Before make a trip, check that all cushions are fastened well.

Always remove the cushions carefully. Do not pull the cushion to open a snap button.



BOW STEP PLATE (IF APPLICABLE)



Fig. 32. Bow step plate.



OPERATING THE CRAFT

REMOVABLE SUNDECK WITH CUSHION (S470NL) (IF APPLICABLE)

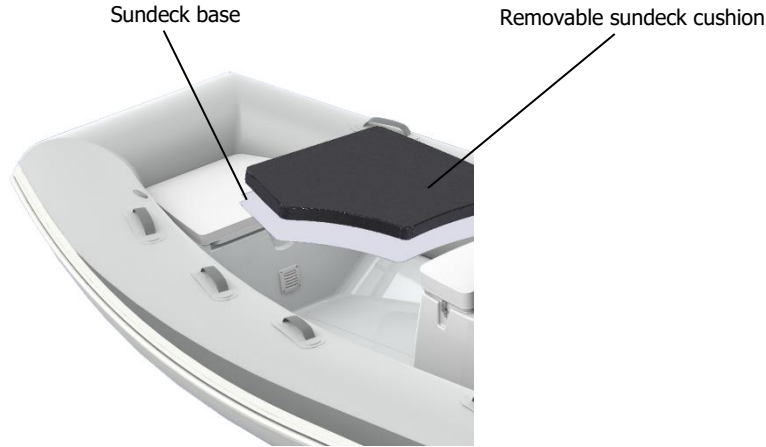

Fig. 33. Removable sundeck with cushion.



WARNING

NEVER USE BOW SUNDECK WHEN THE BOAT IS UNDERWAY. THERE IS A RISK TO FALL OVERBOARD.



CAUTION

ALWAYS STORE REMOVABLE SUNDEC INSIDE THE STORAGE COMPARTMENT IF YOU ARE PLANNING TO CRUISE AT MORE THAN 15 KNOTS.



COLLAPSIBLE BIMINI TOP (IF APPLICABLE)

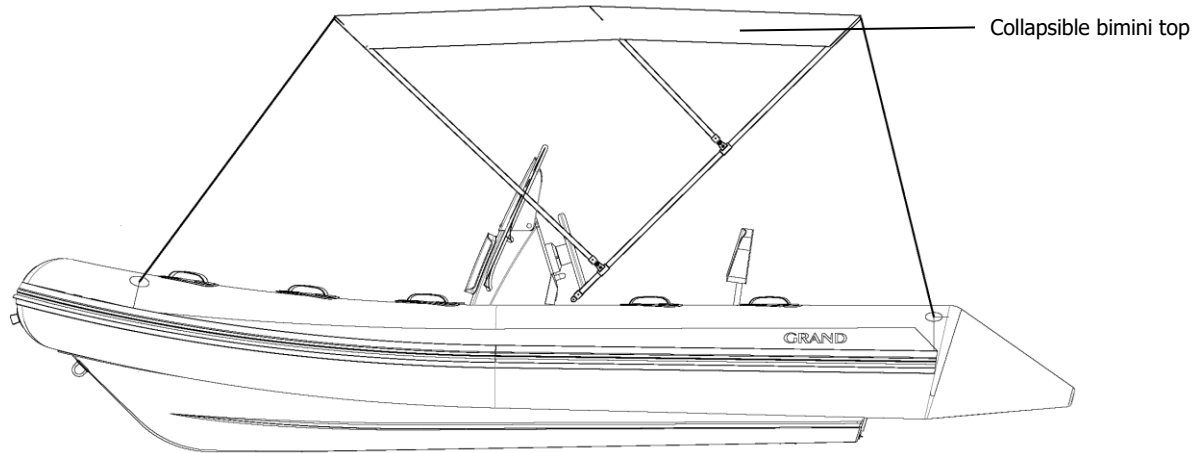

Fig. 34. Collapsible bimini top.

CAUTION

USE A BIMINI TOP WHEN YOUR BOAT IS NOT IN MOTION. KEEP BIMINI TOP IN STOWED POSITION IF YOU PLANNING TO CRUISE AT MORE THAN 20-25 KNOTS.



OPERATING THE CRAFT

BIMINI TOP INSTALLATION PROCEDURE

A bimini top is supplied pre-assembled.

1. Unpack the Bimini Top.
2. Unfold it, then insert the poles into connectors.

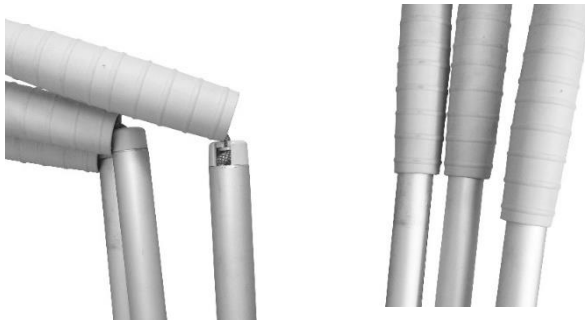

Fig. 35. Close view of connectors.

3. Insert the pole eye end into support, securing by a thumb screw.
4. The same procedure should be repeated on the opposite side.
5. Open a top canvas.
6. Fix the adjustable straps to the attachment structures located on the bow and the stern.
7. Check that the top canvas is well stretched and all fastenings are tightened.



SEADECK ANTISKID SET (IF APPLICABLE)



Fig. 36. SeaDek antiskid product.

Safe and comfortable non-absorbent long life product specially designed for marine application. Textured micro-dot robust surface ensures:

- Exceptional traction even when wet.
- Unparalleled comfort when standing, walking or leaning on boat surfaces.
- Shock absorption, which decreases fatigue.
- Protection for boat surfaces against scratches, chips and dents.
- Noise reduction characteristics – ideal for fishermen.

The following area of your boat (depending on the model) can be enhanced by SeaDek antiskid material:

- Deck
- Bow step plate
- Fiberglass step ends

Extremely stain resistant SeaDek surface, if needed, can be easily cleaned with soap, hot water, and a stiff brush. For best cleaning results tend to remove all stains, spills and leaks as soon as possible.



**DO NOT USE ACID-BASED CLEANERS.
AVOID TO USE HIGH PRESSURE
WASHERS.**



TECHNICAL DETAILS

5. TECHNICAL INFORMATION

TECHNICAL SPECIFICATIONS

See the table below for technical specifications of the S470N/S470NS, S470NL.

Model		S470N/S470NS	S470NL
Specification	Unit		
Length overall	cm	470	470
	ft/inches	15'5"	15'5"
Length internal	cm	340	340
	ft/inches	11'2"	11'2"
Beam width	cm	205	205
	ft/inches	6'9"	6'9"
Width internal	cm	105	105
	ft/inches	3'4"	3'4"
Chambers	Number	5	5
Tube diameter	cm	50	50
	inches	20"	20"
Tube fabric		PVC/Hypalon	PVC/Hypalon
Bare boat weight*	kg	170/200	208
	lbs	374/440	458
Full weight**	kg	226/256	265
	lbs	497/583	583



Loading capacity	kg lbs	900 1980	900 1980
Passenger capacity	Number	8	8
Maximum height (light craft)	m ft/inches	0.75 2' 5"	0.75 2' 5"
Maximum draft (fully loaded), from hull's underside lowest point	m ft/inches	0.35 1' 1"	0.35 1' 1"
Engine recommended	HP kW	50 36.8	50 36.8
Engine max	HP kW	70 51.5	70 51.5
Engine weight max	kg lbs	150 330	150 330
Engine shaft length	inches	20" (long)	20" (long)
Midsection/aft deadrise	degrees	20°/15°	20°/15°

Note:

* - The bare boat weight is just a weight of the boat without any removable accessories.

** - The transport weight in standard package.



TECHNICAL DETAILS

STANDARD AND OPTIONAL EQUIPMENT

STANDARD EQUIPMENT:

- Deep-V hull with original "DART-hull" system
- Soft curved multi-chamber inflatable tube
- Molded in spacious bow locker with access cover
- Towing bow eye, two front and two rear lifting eyes
- Bow grab handle, safety grab handles
- Tough raised rubbing strake with splash guard
- Cockpit drain plug (bailer) and hull drain plug

SPORT VERSION:

- Steering console CS-03 with windshield and handrail
- Mechanical steering system with steering wheel



DELUXE VERSION:

- Steering console CL-14 with windshield, handrail
- Mechanical steering system with steering wheel
- Rear double seat SD-10 with seat back and stowage
- Bow locker removable cushion

OPTIONAL EQUIPMENT:

- Removable sundeck for S470NL
- Complete electric package
- Fiberglass step ends of the inflatable tube
- Stainless steel folding navigation arch
- Bow step plate with anchor roller and cleat
- Bow locker removable cushion (S470N and S470NS)
- Collapsible bimini top
- Overall cover, console cover
- Overpressure valve
- Keel and tube protector packages
- SILVERTEX upholstery upgrade
- SeaDek® antiskid set (for DELUXE version)



TECHNICAL DETAILS

COMPARTMENT CHART

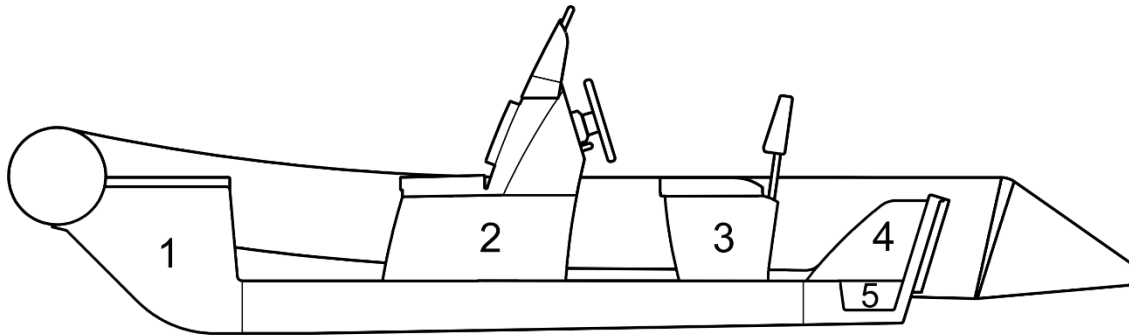

- | | |
|-----------------------|-----------------------------|
| 1. Bow locker | 4. Rear open storage volume |
| 2. Console storage | 5. Drain well |
| 3. Double seat locker | |

Fig. 37. Compartment chart.



GENERAL ARRANGEMENT OF A BOAT S470N (S470NF)



- | | | | |
|----|---------------------------|----|---------------------|
| 1. | Buoyancy inflatable tube | 5. | Cockpit |
| 2. | Inflation/deflation valve | 6. | Fiberglass step end |
| 3. | Safety handle | 7. | Transom plate |
| 4. | Bow locker | 8. | Cockpit drain plug |

Fig. 38. General arrangement of a boat S470N (S470NF).



TECHNICAL DETAILS

GENERAL ARRANGEMENT OF A BOAT S470NS (S470NSF)

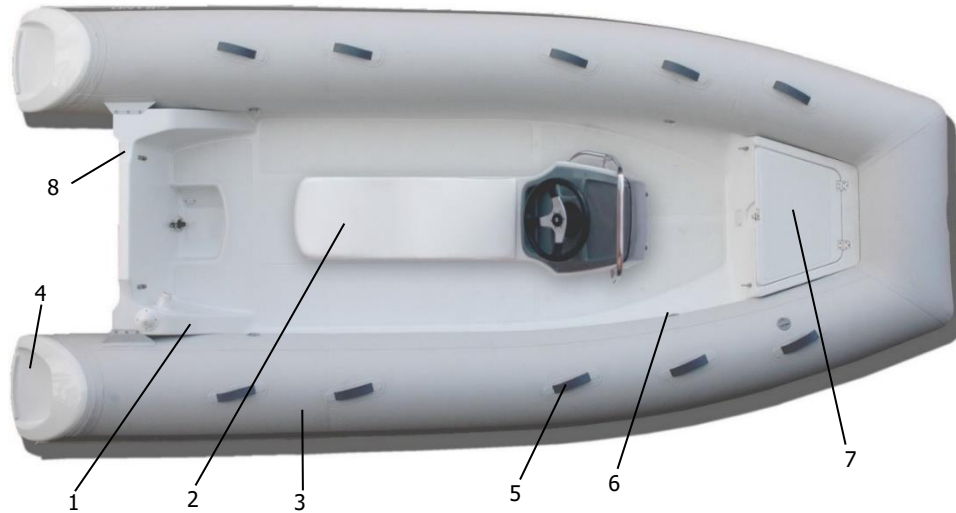

- | | |
|------------------------|------------------------------|
| 1. Fiberglass hull | 5. Safety handle |
| 2. Steering console | 6. Inflation/deflation valve |
| 3. Buoyancy tube | 7. Bow locker |
| 4. Fiberglass step end | 8. Transom plate |

Fig. 39. General arrangement of a boat S470NS (S470NSF).

GENERAL ARRANGEMENT OF A BOAT S470NL (S470NLF)

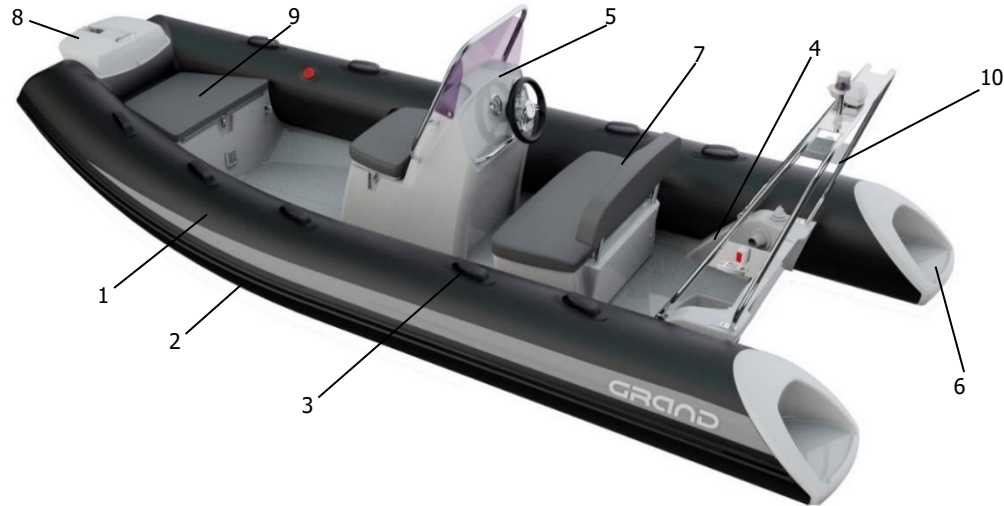

- | | | | |
|----|----------------------------------|-----|-------------------------|
| 1. | Buoyancy tube | 5. | Steering console |
| 2. | Rubbing strake with splash guard | 6. | Fiberglass step end |
| 3. | Safety handle | 7. | Double seat |
| 4. | Fiberglass hull | 8. | Bow step plate |
| | | 9. | Bow locker |
| | | 10. | Folding navigation arch |

Fig. 40. General arrangement of a boat S470NL (S470NLF).



TECHNICAL DETAILS

STEERING CONSOLE COMPONENTS

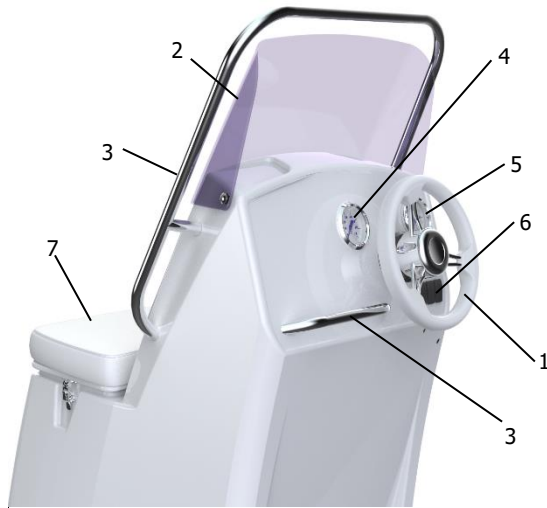

- Steering system
- Steering cable
- Steering wheel (1)
- Windshield (2)
- Handrail (3)
- Throttle lever (optional*)
- Speedometer (optional*) (4)
- Fuel indicator (optional*)
- Tachometer (optional*) (5)
- Switches (6)
- Front seat (7)

Fig. 41. Steering console components.

When your trip is finished, always remove the key from the ignition switch. This will prevent theft or unauthorized use of your boat.

* -Please contact your regional Dealer for the installation of required components.



GENERAL VIEW OF A BOAT S470N

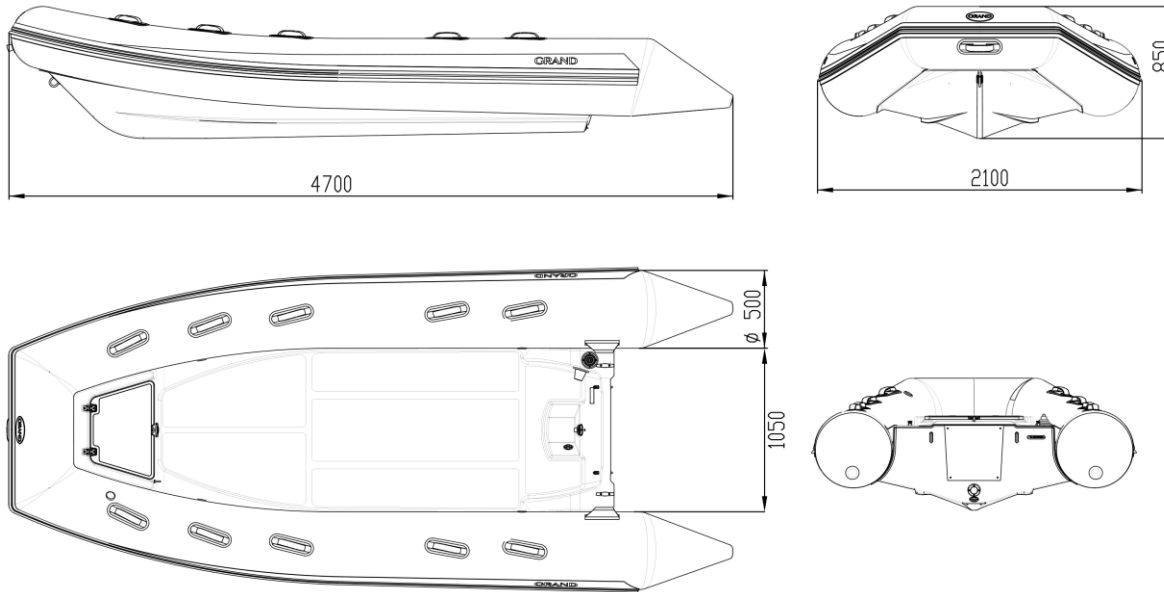

Fig. 42. General view of a boat S470N.



TECHNICAL DETAILS

GENERAL VIEW OF A BOAT S470NS

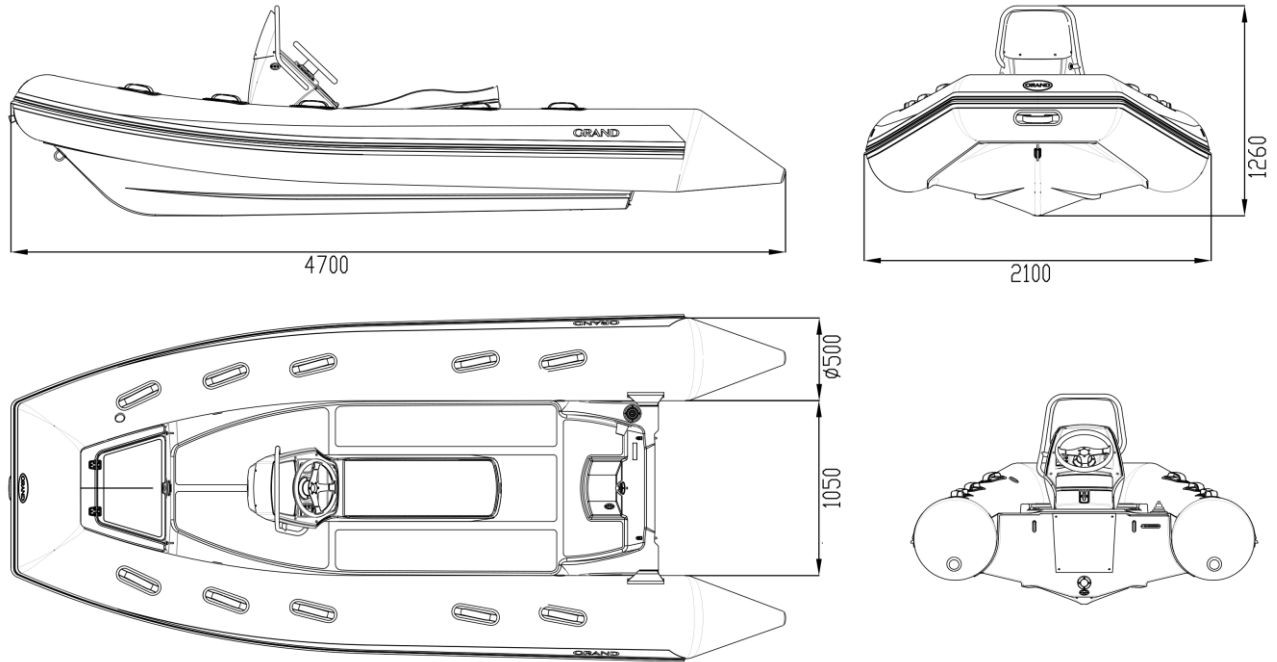

Fig. 43. General view of a boat S470NS.



GENERAL VIEW OF A BOAT S470NL

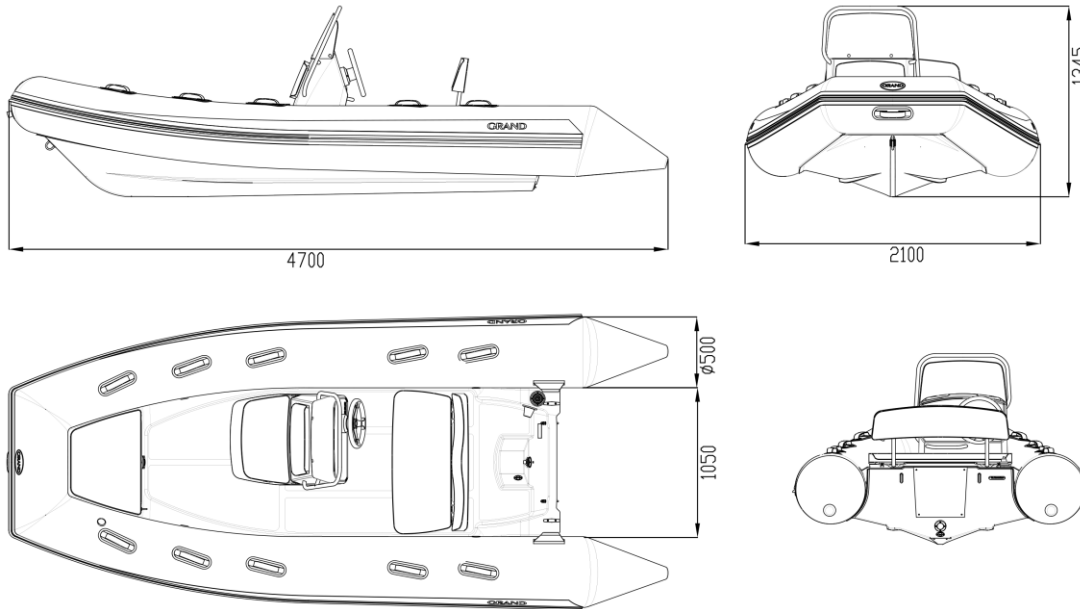

Fig. 44. General view of a boat S470NL.



TECHNICAL DETAILS

LOADING PASSENGERS FOR S470NS (S470NSF)

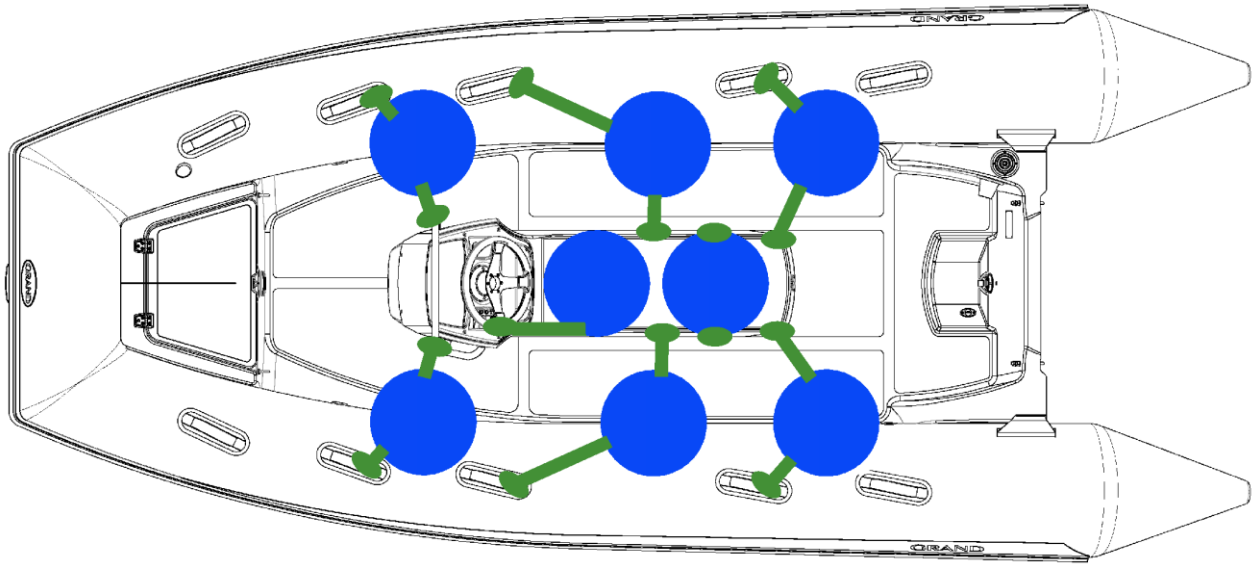

Fig. 45. Recommended seating arrangement for 8 persons.



LOADING PASSENGERS FOR S470NL (S470NLF)

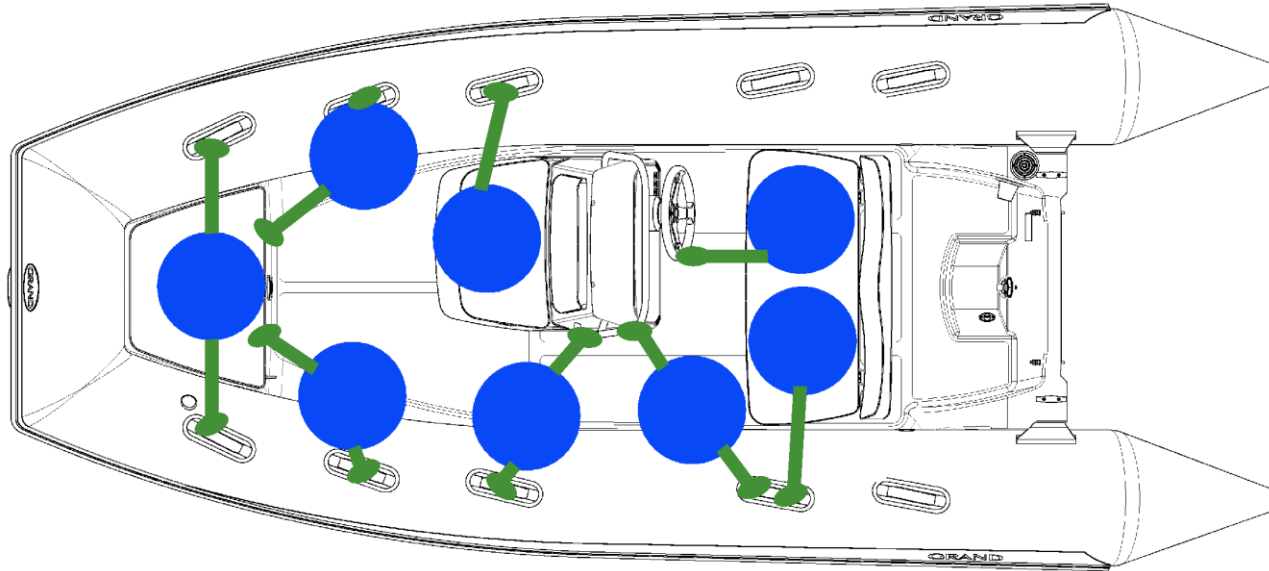

Fig. 46. Recommended seating arrangement for 8 persons.



TECHNICAL DETAILS

ELECTRICAL SCHEMATIC DIAGRAM

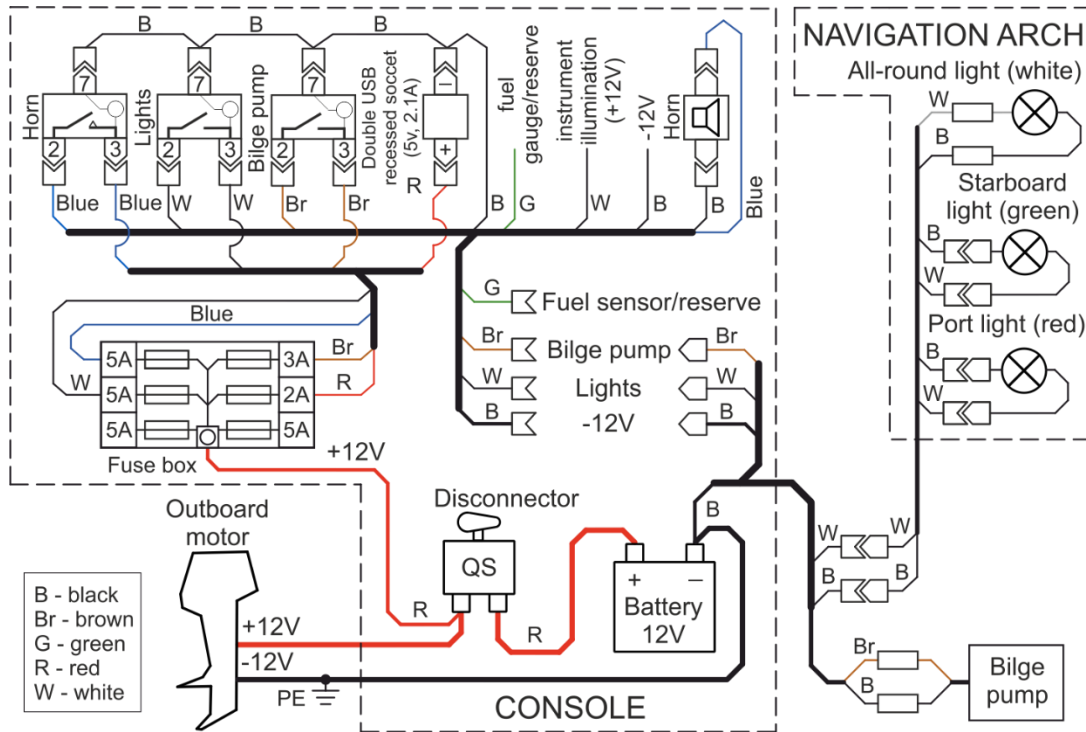

Fig. 47. Electrical schematic diagram for a boat with all nav. lights on the arch.

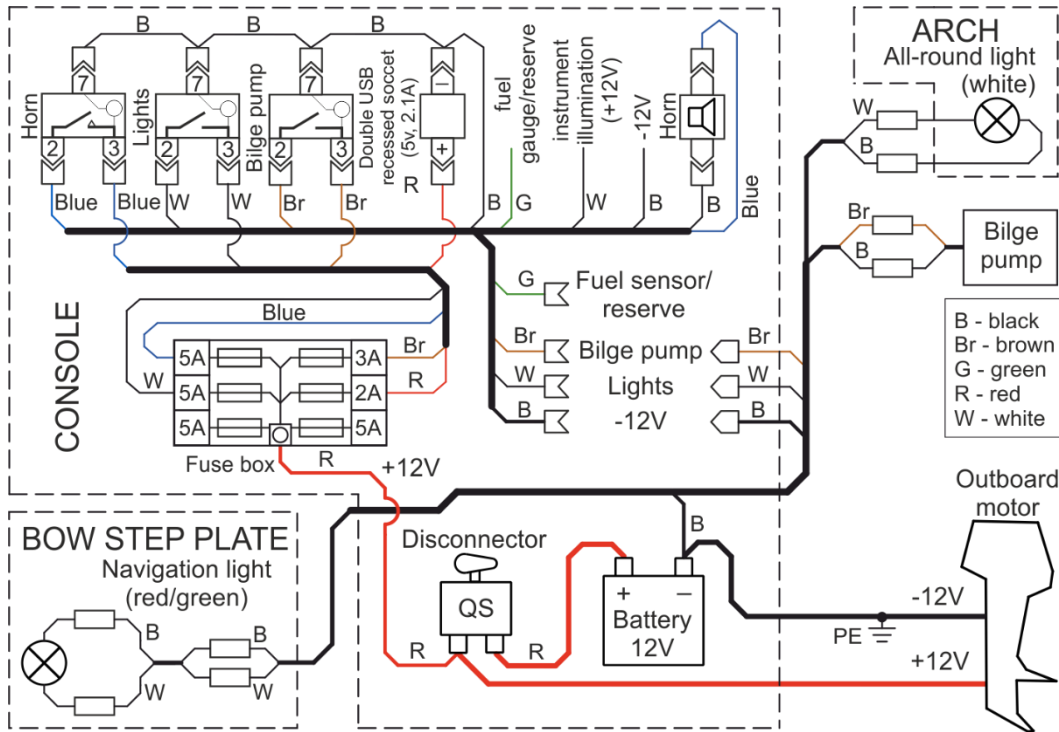

Fig. 48. Electrical schematic diagram for a boat with the nav. lights on the arch and bow step plate.



SERVICE AND MAINTENANCE

6. SERVICE AND MAINTENANCE

Only high-quality materials suited for marine environments are used in production of our boats. Nevertheless, without a regular and proper maintenance, the moisture and saltiness inherent to this environment can reduce their service life.

A dedicated cover for the whole boat is the best protection against UV degradation of gelcoat and fabric of the tube.



CAUTION

YOU SHOULD NOT USE STEAM BLASTERS AS THEY CAN AFFECT THE STRENGTH OF THE TUBE GLUED SEAMS.

NEVER USE A SANDBLASTING MACHINE FOR CLEANING.



CLEANING

- Regularly clean your boat and make sure this is done before winterizing.
- For cleaning use household cleaner (non abrasive) and fresh water only!
- At all times keep the inflatable tube, vinyl and other boat parts free of any chemical spills, such as:
 - Gasoline, grease, oil and any other oily product.
 - Suntan oils, lotions and any other body care products.
 - Pollution products, dirt and dust.
 - Silicon based products.
- If any of the above listed spills occur on the boat's surface clean and wash the boat or its relevant part as soon as possible, and only with approved liquids.
- When not in use keep your boat properly covered.
- Keep your boat away and properly protected against car's exhaust smoke pollution and heat: this may damage the boat.

Use cleaning agents specifically formulated for cleaning inflatable boats and RIBs.

A high-pressure washer can be used for cleaning the hull.



CAUTION

DON'T USE A HIGH-PRESSURE WASHER FOR TUBE WASHING.



SERVICE AND MAINTENANCE

CLEANING OF TUBE

An important factor for the long life of tube fabric is regular adequate cleaning.

The subsequent cleaning procedure is recommended:

- Rinse off with clear, tap water (approx. 20 °C).
- Use gentle soapy water (pH value neutral to slightly alkaline) to wash the tube by means of a soft cloth or brush. Do not leave the soapy water on the surface for more than 5 minutes.
- Clean the surface very thoroughly and make sure that no soap residue remains on the surface.
- Then dry by wiping off the surface with a soft cloth.

CLEANING THE UNDERWATER PART OF THE TUBE

Place the boat on a stand so that the underwater part of the tube is accessible.

To clean the part of the tube which is under water most of the time from the deposits, it is best to use a well-rounded wooden or plastic spatula.

While thoroughly wetting the surface, gently remove dirt, sand, algae, and other deposits.

A soapy solution or household detergent can be used. Then, rinse it thoroughly with fresh water. Wipe gently off with a soft cloth.



CAUTION

DO NOT USE THE FOLLOWING PRODUCTS TO CLEAN THE TUBE:

- Any cleaning device that might cause mechanical damage to the surface such as hard brushes, high-pressure washers, etc.
- Any cleaning agents (scouring agents or scrubbing powder), which will damage the surface;
- Strong alkaline cleaning agents.
- Acid cleaning agents.
- Solvent based cleaning agents (e. g. based on ester, ketone, ether, furan or benzol).
- Petrol, diesel, kerosene.
- Self-made cleaning agents.
- Bleaching or oxidizing cleaning agents (e.g. containing hydrogen peroxide, sodium hypochlorite, chlorine dioxide or sodium dithionite).



SERVICE AND MAINTENANCE

PLASTIC PRESERVATION

Surface quality may degrade by solar exposure, heat, salt deposits, anthropogenic pollution and vehicle exhaust gases.

The gelcoat surfaces will last a long time if regularly and properly cared for.

Keeping the surface clean and periodic waxing are key points in gelcoat care.

In the marine environment, protection of plastic surfaces must be applied more regularly than on your car because the sun is stronger and the horizon is longer than on shore.

Gelcoat care must be carried out in several stages.

CLEANING

The first step in any boat maintenance program is dirt removal. Use a detergent and a sponge specially dedicated for this purpose.

Rinse the sponge frequently in a separate bucket of water to prevent salt and dirt from moving around on gelcoat surface. Rinse the surface thoroughly with clean water and wipe it dry with a synthetic chamois or clean towel, just as you would wash your car.



SALT REMOVAL

If salt deposits are left on the gelcoat surface, it will look dull and stained even after polishing and waxing. To remove salt buildup, use the special agents or white vinegar.

Rinse the surface thoroughly off with clean water when finished, and wipe dry with a synthetic chamois or clean towel.

POLISHING

Polishing is an important step in order to keep the gelcoat surface in good condition.

Polishing should be done only by special pastes application.

Polishing can be made manually or by using a slow-speed electric buffer. All works should be carried out on land when using a power tool.

Polish no more frequently than is necessary, and then use the least abrasive material that will do the job.

WAXING

Use special waxes.

Be sure to read the instructions before application.

Preferably choose the time to work or position the boat so you can work in the shade, both to keep the surface cool and to keep from going blind.



SERVICE AND MAINTENANCE

CLEANING OF THE UNDERWATER PART OF THE HULL FROM DEPOSITS

Cleaning with a high-pressure washer

The best means for removing stubborn deposits is a high-pressure washer.

However, when using a high-pressure washer, use it carefully so that the jet does not hit the tube.



CAUTION

THE USE OF A HIGH-PRESSURE WASHER TO CLEAN THE TUBE IS PROHIBITED. THE TUBE FABRIC CAN BE DAMAGED.

Cleaning with a spatula

To clean the fiberglass hull, place the boat on a stand so that most of the bottom is accessible. It is best to use a wooden or metal spatula with a flat tip. While thoroughly wetting the surface, gently remove dirt, sand, algae, and other deposits.

ANTIFOULING HULL PROTECTION

After the hull has been washed and well dried, apply an antifouling paint, if necessary.

Before working with antifouling paint, read carefully the instruction for use it.



UPHOLSTERY CARE

All upholstery of your boat is made from high quality coated fabrics.

Keeping upholstery dry and clean will not only maintain its appearance but also extend its life.

It's a good practice to clean it once a week. For deeper cleaning use soft brush once a month.

Remove stains as quick as possible, preferably within 24 hours.

Use liquid hand soap and water (1-part soap to 9 parts water), cotton, flannel white cloth by cleaning the upholstery in circular motions. Dry well.

After each use of boat, all upholstery should be well dried.

REMEMBER

Light colors upholstery should be maintained more attentively and more often.



CAUTION

- Do not use pressure washing
- Do not use powdered abrasives
- Do not use solvents, acetone, whiteners, waxes, silicones and other harsh chemicals

STORAGE

If you don't use the boat, take care to cover all upholstery to protect it from environment hazards.

During the storage, be sure about free air circulation around the cushions.



SERVICE AND MAINTENANCE

ACRYLIC GLASS WINDSHIELD CARE

Only clean water and soft microfiber, cotton or flannel cloth should be used for acrylic glass windshield cleaning.

To remove stubborn stains, use only cleaners formulated specifically for cleaning acrylic surfaces.



CAUTION

TO PREVENT SCRATCHES, DAMAGE, TURBIDITY AND OTHER DEFECTS:

- Do not make dry cleaning
- Do not use rough sponges or papers
- Do not use powdered abrasive cleaners
- Do not use harsh chemicals like petrol, acetone, ammonia-based cleaners, solvents (provoke cracks formation), alcohol and alcohol-based liquids, etc.



AIRTIGHTNESS OF THE INFLATABLE TUBE

The tube is considered to be airtight if it retains the recommended inflation pressure for 8 hours.

- As the inflatable tube is a primary safety feature - check the airtightness of your boat regularly. Inspect the condition of all inflatable components and remember that some natural release of pressure (see the information below) can occur. Make sure that:
 - There are no material cracks, holes and leaks.
 - All inflation valves and seams are intact.
 - According to ISO 6185 standard a 20% drop in pressure within 24 hours is not critical.
 - If you discover a small drop in pressure add some air using the foot pump supplied.



WARNING

NEVER USE HIGH-PRESSURE EQUIPMENT TO INFLATE YOUR BOAT.

Changes in ambient temperature have a significant influence on air pressure within the tube. A variation of 1°C results in a variation in pressure of about +/- 4 mb (0,06 psi).



SERVICE AND MAINTENANCE

IN CASE OF AN AIR LEAKAGE

If a significant drop of pressure has occurred, make a visual check of the tube:

- Step 1 - check the inflation/deflation valves and overpressure valves - *if there is no contamination and all seals are in good state.*
- Step 2 - check the major seams.
- Step 3 - check the tube material from top to bottom.

If you are not able to see any obvious sources of leakage, in way to find a defect, first inflate all tube compartments to nominal pressure, then spray a soapy solution on all surfaces including tube material, main seams and valves. In a leakage spot the air bubbles should be appeared. Mark the location of the defect with a pencil. No pen or marker can be used! You will be not able to remove their traces.

Remember to rinse thoroughly the soap solution-treated areas off with clean water after the checking is over.

Any source of leakage must be properly repaired.

Contact your Dealer for advice if necessary.



CAUTION

DO NOT OPERATE YOUR BOAT IF THE PRESSURE DROP IN THE TUBE IS MORE THAN 20% PER DAY.



MAINTENANCE OF STAINLESS STEEL

We use only top-quality stainless steels, which are resistant to corrosion. However, this may not be permanent and maintenance is sometimes required so:

- Avoid contamination and scoring to the surface.
- Frequently wash with fresh water.
- Once the surface is dry, apply some Vaseline or a dedicated grease for stainless steel and buff up to a high gloss by a rag.
- If you see a sign of rust – clean and mirror polish the area as soon as possible.

WINTERIZING AND STORAGE

When storing your boat, keep it in a clean and dry place so it is not affected by major temperature fluctuations and other conditions.

- You may store the boat:
 - Assembled and partly inflated with a cover so as to protect it from direct sunlight, dirt, dust and pollution.
- For winterizing:
 - Clean and dry the boat, including seat cushions and any plywood components.
 - Completely drain all water from the hull and bilge compartment.
 - Disconnect and remove the battery.
 - Grease all metal moving parts and connections, including steering.
 - Properly close the fuel system to avoid any vapour leaks.
- If possible, allow air to circulate within the boat, a breathable canvas cover will help.



SERVICE AND MAINTENANCE

Winterize the motor, following the manufacturer's instructions.



CAUTION

1. WHEN THE BOAT IS IN STORAGE MAKE SURE IT IS COVERED.
2. STORE THE BOAT AWAY FROM RODENTS.
3. AVOID SHARP FOLDS IN THE TUBE MATERIAL.

REGULAR INSPECTIONS

- Check frequently all navigation lights, horn, VHF radio (if fitted), safety handles, handrails and all other safety related equipment.
- Check frequently the tightness of various screws, bolts and nuts, with particular attention to those holding the engine onto the transom. Also check all steering system components are secure and functioning correctly.
- Regularly examine your fuel system, replace old or damaged components and check the tightness of the fuel line connections.



DANGER

REGULARLY CHECK THE TIGHTNESS OF THE ENGINE TRANSOM BOLTS AS THEY MAY BE AFFECTED BY VIBRATION.



7. TRAILERING

The size and carrying capacity of the trailer should be suitable for the size and weight of your boat including the engine. Do not use a trailer that is too big or too small for your boat. Use a BUNK trailer. Make sure that the trailer provides adequate support for the keel because basis weight of the boat is to be supported by the keel. Lateral bunks should be used just for extra support and stability.



Fig. 49. Trailer.

LIFTING THE BOAT

To lift the boat and place it on davits, use the factory fitted lifting eyes only, or have them installed by your Dealer if the boat is not equipped. Use only certified and rated lifting slings, appropriate for your boat and motor weight.



WARNING

MAKE SURE NOBODY IS ON BOARD WHEN LIFTING.

WHEN LIFTED, THE BOAT SHOULD BE EMPTY (NO REMOVABLE EQUIPMENT) AND TIPPED SLIGHTLY TOWARD THE REAR WITH COCKPIT AND HULL DRAIN PLUGS OPEN.



TRAILERING

BOAT TOWING

Before towing your boat please refer to the trailer manufacturer's manual and also note the following:

- Make sure that the trailer provides adequate support for the keel and bunks that provide large contact areas for the hull.
- The boat is properly inflated and the cockpit drain plug is open.
- Haul the boat onto the trailer using the bow eye.
- Make sure that the outboard engine leg is in the "trailer position". Refer to manufacturer's manual.
- Secure the boat to the trailer with suitable straps or rope, using bow, lateral and rear eyes for this purpose.
- Close and secure all hatches and openings on the boat. Cushions must be placed in lockers or removed to prevent loss during transit.

IMPORTANT NOTICE

Do not trailer the boat with the overall cover in place, it is not designed for transportation.



8. RESPECTING THE ENVIRONMENT

REMEMBER THAT RESPONSIBLE BOATING BEGINS WITH YOU!

Respect your environment by applying the following basic rules:

- AVOID CREATING EXCESSIVE WASH.
- KEEP OUT OF DESIGNATED SWIMMING AREAS.
- RESPECT ALL ANIMAL LIFE.
- BE CAREFUL NOT TO OVERFILL THE FUEL TANK.
- DON'T MAKE UNNECESSARY NOISE.
- DO NOT DISCHARGE OIL OR FUELS INTO THE WATER.
- DO NOT LITTER.

The health of our environment depends on us all acting responsibly to ensure a clean tomorrow. If each of us follows these few simple rules, we can help to keep the Earth's resources intact for future generations.



WARRANTY

9. GRAND'S WARRANTY

GENERAL

Subject to the terms and conditions detailed below, Grand Marine Corporation warrants that Grand Inflatable Boats are free from defects in material or workmanship for the defined warranty period, and will, at its option, repair or replace defective parts on return of the craft to the premises of an Authorised Grand Reseller.

This warranty applies to new Grand Inflatable Boats purchased from an Authorised Grand Marine Reseller.

By using the Grand Inflatable Boats, the owner and helmsman understands and agree to undertake all instructions in the Grand Owner's Manual, and agrees to all warranty and liability terms and conditions contained in this warranty.

WARRANTY PERIOD

Grand warrants Grand branded components from the date of purchase for a period of:

- 24 consecutive months for normal personal recreational use*.

* - Normal recreational use is defined as not more than 100 annual return trips with not more than 100 annual outboard hours. Greater annual usage than this is not covered by the Grand recreational warranty.



WARRANTY COVERAGE

The Grand warranty covers the following:

- Grand hull and its appropriated hull components.
- Inflatable tubes.

This warranty is limited to repair, or at Grand option, replacement of parts suffering from any of the defects described above during the warranty period. The judgment of Grand is final concerning the extent of items covered under above warranty.

The outboard engine, electrical and electronic components, other auxiliaries are subject of the warranty of the appropriate Manufacturer.

The warranty is not applicable in case the boat was not used for recreational purposes.



WARRANTY

WARRANTY EXCLUSIONS

Grand warranty does not cover the following:

- Replacement of parts due to normal wear and tear.
- Routine maintenance parts and services, including but not limited to, maintenance requirements, oil and lubrication, replacement of fuses or bulbs, linkage adjustments, filters and spark plugs, tyres, and other consumable items.
- Damage caused by not following procedures and recommendations in the Grand Owner's Manual.
- Operating the craft beyond the design category.
- Damage caused by improper or lack of maintenance, winterization or storage.
- Damage caused by abuse, impact, accident, misuse, abnormal use or strain, neglect, racing, improper operation or operation not in accordance with the recommended procedures described in the Grand Owner's Manual.
- Damage or cosmetic changes due to exposure to the atmospheric or environmental conditions, including mould or marine organisms, or outside galvanic activity.
- Damage resulting from tears, punctures, abrasions, abuse, external damage, accident, submersion, water ingestion or contamination, fire, theft.



WARRANTY CERTIFICATE

Name of Customer: _____

Address: _____

City: _____ Post code: _____

E-mail _____ Phone number: _____

WIN (Serial number): _____

Signature: _____

Dealer address: _____

City: _____ Post code: _____

Date of purchase: _____

Seller and customer acknowledge by signing that seller handed and customer received hereinbefore boat including standard (optional, if relevant) equipment and manual in English and that the boat is without evident defects.

SELLER SIGNATURE:

CUSTOMER SIGNATURE:

FOR YOUR NOTES

GRAND

INFLATABLE BOATS

Potemkina str. 18a, Solonicevka 62370,
Dergachevsky distr., Kharkovskaya obl.,
UKRAINE

Tel: +380 57 7840125

Tel/fax: +380 57 7840124

www.grandboats.com

mail@grandmarine.com.ua



Scan & visit
our official
website &
social media