



OWNER'S MANUAL

**⚠ Read this manual carefully
before operating this vehicle.**

XSR 900

MOTORCYCLE

MTM890 (XSR900)

MTM890-U (XSR900 35kW)

BEA-28199-E1●

Safety information	1
Description	2
Special features	3
Instrument and control functions	4
For your safety – pre-operation checks	5
Operation and important riding points	6
Periodic maintenance and adjustment	7
Motorcycle care and storage	8
Specifications	9
Consumer information	10
Index	11

 **Read this manual carefully before operating this vehicle. This manual should stay with this vehicle if it is sold.**

Declaration of Conformity:

Hereby, YAMAHA MOTOR ELECTRONICS Co., Ltd declares that the radio equipment type, IMMOBILIZER, B7N-00 is in compliance with Directive 2014/53/EU.

The full text of the EU declaration of conformity is available at the following internet address:

https://global.yamaha-motor.com/eu_doc/

Frequency band: 134.2 kHz

The maximum radio frequency power: 49.0 [dB μ V/m]

Manufacturer:

YAMAHA MOTOR ELECTRONICS Co., Ltd

1450-6 Mori, Mori-machi, Shuchi-Gun, Shizuoka, 437-0292 Japan

Importer:

YAMAHA MOTOR EUROPE N.V.

Koolhovenlaan 101, 1119 NC Schiphol-Rijk, 1117 ZN, Schiphol, the Netherlands

For UK

**UK
CA**

Declaration of Conformity:

Hereby, YAMAHA MOTOR ELECTRONICS Co., Ltd declares that the radio equipment type, IMMOBILIZER, B7N-00 is in compliance with the Radio Equipment Regulations 2017.

The full text of the declaration of conformity is available at the following internet address:

https://global.yamaha-motor.com/eu_doc/

Frequency band: 134.2 kHz

The maximum radio frequency power: 49.0 [dB μ V/m]

Manufacturer:

YAMAHA MOTOR ELECTRONICS Co., Ltd

1450-6 Mori, Mori-machi, Shuchi-Gun, Shizuoka, 437-0292 Japan

Importer:

YAMAHA MOTOR EUROPE N.V., BRANCH UK

Units A2-A3, Kingswey Business Park, Forsyth Road, Woking, Surrey. GU21 5SA. United Kingdom.

Introduction

EAU10103

Welcome to the Yamaha world of motorcycling!

As the owner of the MTM890/MTM890-U, you are benefiting from Yamaha's vast experience and newest technology regarding the design and manufacture of high-quality products, which have earned Yamaha a reputation for dependability.

Please take the time to read this manual thoroughly, so as to enjoy all advantages of your MTM890/MTM890-U. The Owner's Manual does not only instruct you in how to operate, inspect and maintain your motorcycle, but also in how to safeguard yourself and others from trouble and injury.

In addition, the many tips given in this manual will help keep your motorcycle in the best possible condition. If you have any further questions, do not hesitate to contact your Yamaha dealer.

The Yamaha team wishes you many safe and pleasant rides. So, remember to put safety first!

Yamaha continually seeks advancements in product design and quality. Therefore, while this manual contains the most current product information available at the time of printing, there may be minor discrepancies between your motorcycle and this manual. If there is any question concerning this manual, please consult a Yamaha dealer.

EWA10032





Please read this manual carefully and completely before operating this motorcycle.

Important manual information

EAU10134

Particularly important information is distinguished in this manual by the following notations:

	This is the safety alert symbol. It is used to alert you to potential personal injury hazards. Obey all safety messages that follow this symbol to avoid possible injury or death.
 WARNING	A WARNING indicates a hazardous situation which, if not avoided, could result in death or serious injury.
NOTICE	A NOTICE indicates special precautions that must be taken to avoid damage to the vehicle or other property.
TIP	A TIP provides key information to make procedures easier or clearer.

*Product and specifications are subject to change without notice.

Important manual information

EAU10202

**MTM890/MTM890-U
OWNER'S MANUAL**
©2024 by Yamaha Motor Co., Ltd.
1st edition, December 2023
All rights reserved.
Any reprinting or unauthorized use
without the written permission of
Yamaha Motor Co., Ltd.
is expressly prohibited.
Printed in Japan.

Table of contents

Safety information	1-1	Seat	4-26	Checking the spark plugs	7-10
Description	2-1	Rider footrest position	4-27	Canister	7-11
Left view	2-1	Handlebar position	4-27	Engine oil	7-12
Right view	2-2	Adjusting the front fork	4-27	Why Yamalube	7-13
Controls and instruments	2-3	Adjusting the shock absorber assembly	4-30	Coolant	7-13
Special features	3-1	Auxiliary DC connectors	4-31	Air filter element	7-14
Cruise control system	3-1	Sidestand	4-32	Checking the engine idling speed ...	7-15
“D-MODE”	3-3	Ignition circuit cut-off system	4-32	Valve clearance	7-15
“TCS-MODE”	3-4	For your safety – pre-operation checks	5-1	Tires	7-15
Quick shifter	3-6	Operation and important riding points	6-1	Cast wheels	7-18
BC	3-6	Engine break-in	6-1	Adjusting the clutch lever free play	7-18
Instrument and control functions	4-1	Starting the engine	6-2	Checking the brake lever free play	7-19
Immobilizer system	4-1	Shifting	6-3	Brake light switches	7-19
Main switch/steering lock	4-2	Tips for reducing fuel consumption	6-4	Checking the front and rear brake pads	7-20
Handlebar switches	4-3	Parking	6-5	Checking the brake fluid level	7-20
Indicator lights and warning lights	4-5	Periodic maintenance and adjustment	7-1	Changing the brake fluid	7-22
Display	4-9	Tool kit	7-2	Drive chain slack	7-22
Settings MENU	4-15	Periodic maintenance charts	7-3	Cleaning and lubricating the drive chain	7-24
Clutch lever	4-19	Periodic maintenance chart for the emission control system	7-3	Checking and lubricating the cables	7-25
Shift pedal	4-20	General maintenance and lubrication chart	7-4	Checking and lubricating the throttle grip	7-25
Brake lever	4-20	Side cover	7-8	Checking and lubricating the brake and shift pedals	7-25
Brake pedal	4-21			Checking and lubricating the brake and clutch levers	7-26
Brake control system (BC)	4-21				
Fuel tank cap	4-23				
Fuel	4-23				
Fuel tank overflow hose	4-25				
Catalytic converter	4-26				

Table of contents

Checking and lubricating the sidestand	7-27
Lubricating the swingarm pivots	7-27
Checking the front fork	7-27
Checking the steering	7-28
Checking the wheel bearings	7-28
Battery	7-29
Replacing the fuses	7-31
Vehicle lights	7-33
License plate light	7-33
Supporting the motorcycle	7-33
Troubleshooting	7-34
Troubleshooting chart	7-35
Motorcycle care and storage	8-1
Matte color caution	8-1
Care	8-1
Storage	8-4
Specifications	9-1
Consumer information	10-1
Identification numbers	10-1
Diagnostic connector	10-2
Use of your data	10-3
Index	11-1

EAU1028C

Be a Responsible Owner

As the vehicle's owner, you are responsible for the safe and proper operation of your motorcycle.

Motorcycles are single-track vehicles. Their safe use and operation are dependent upon the use of proper riding techniques as well as the expertise of the operator. Every operator should know the following requirements before riding this motorcycle.

He or she should:

- Obtain thorough instructions from a competent source on all aspects of motorcycle operation.
- Observe the warnings and maintenance requirements in this Owner's Manual.
- Obtain qualified training in safe and proper riding techniques.
- Obtain professional technical service as indicated in this Owner's Manual and/or when made necessary by mechanical conditions.

- Never operate a motorcycle without proper training or instruction. Take a training course. Beginners should receive training from a certified instructor. Contact an authorized motorcycle dealer to find out about the training courses nearest you.

Safe Riding

Perform the pre-operation checks each time you use the vehicle to make sure it is in safe operating condition. Failure to inspect or maintain the vehicle properly increases the possibility of an accident or equipment damage. See page 5-1 for a list of pre-operation checks.

- This motorcycle is designed to carry the operator and a passenger.
- The failure of motorists to detect and recognize motorcycles in traffic is the predominating cause of automobile/motorcycle accidents. Many accidents have been caused by an automobile driver who did not see the motorcycle. Making yourself conspicuous appears to

be very effective in reducing the chance of this type of accident.

Therefore:

- Wear a brightly colored jacket.
- Use extra caution when you are approaching and passing through intersections, since intersections are the most likely places for motorcycle accidents to occur.
- Ride where other motorists can see you. Avoid riding in another motorist's blind spot.
- Never maintain a motorcycle without proper knowledge. Contact an authorized motorcycle dealer to inform you on basic motorcycle maintenance. Certain maintenance can only be carried out by certified staff.
- Many accidents involve inexperienced operators. In fact, many operators who have been involved in accidents do not even have a current motorcycle license.
 - Make sure that you are qualified and that you only lend your motorcycle to other qualified operators.

Safety information

1

- Know your skills and limits. Staying within your limits may help you to avoid an accident.
- We recommend that you practice riding your motorcycle where there is no traffic until you have become thoroughly familiar with the motorcycle and all of its controls.
- Many accidents have been caused by error of the motorcycle operator. A typical error made by the operator is veering wide on a turn due to excessive speed or undercornering (insufficient lean angle for the speed).
 - Always obey the speed limit and never travel faster than warranted by road and traffic conditions.
 - Always signal before turning or changing lanes. Make sure that other motorists can see you.
- The posture of the operator and passenger is important for proper control.
 - The operator should keep both hands on the handlebar and both feet on the operator footrests during operation to maintain control of the motorcycle.
- The passenger should always hold onto the operator, the seat strap or grab bar, if equipped, with both hands and keep both feet on the passenger footrests. Never carry a passenger unless he or she can firmly place both feet on the passenger footrests.
- Never ride under the influence of alcohol or other drugs.
- This motorcycle is designed for on-road use only. It is not suitable for off-road use.

Protective Apparel

The majority of fatalities from motorcycle accidents are the result of head injuries. The use of a safety helmet is the single most critical factor in the prevention or reduction of head injuries.

- Always wear an approved helmet.
- Wear a face shield or goggles. Wind in your unprotected eyes could contribute to an impairment of vision that could delay seeing a hazard.

- The use of a jacket, heavy boots, trousers, gloves, etc., is effective in preventing or reducing abrasions or lacerations.
- Never wear loose-fitting clothes, otherwise they could catch on the control levers, footrests, or wheels and cause injury or an accident.
- Always wear protective clothing that covers your legs, ankles, and feet. The engine or exhaust system become very hot during or after operation and can cause burns.
- A passenger should also observe the above precautions.

Avoid Carbon Monoxide Poisoning

All engine exhaust contains carbon monoxide, a deadly gas. Breathing carbon monoxide can cause headaches, dizziness, drowsiness, nausea, confusion, and eventually death.

Carbon Monoxide is a colorless, odorless, tasteless gas which may be present even if you do not see or smell any engine exhaust. Deadly levels of carbon monoxide can collect rapidly and you can quickly be overcome and unable to save yourself. Also, deadly

levels of carbon monoxide can linger for hours or days in enclosed or poorly ventilated areas. If you experience any symptoms of carbon monoxide poisoning, leave the area immediately, get fresh air, and SEEK MEDICAL TREATMENT.

- Do not run engine indoors. Even if you try to ventilate engine exhaust with fans or open windows and doors, carbon monoxide can rapidly reach dangerous levels.
- Do not run engine in poorly ventilated or partially enclosed areas such as barns, garages, or carports.
- Do not run engine outdoors where engine exhaust can be drawn into a building through openings such as windows and doors.

Loading

Adding accessories or cargo to your motorcycle can adversely affect stability and handling if the weight distribution of the motorcycle is changed. To avoid the possibility of an accident, use extreme caution when adding cargo or accessories to your motorcycle. Use

extra care when riding a motorcycle that has added cargo or accessories. Here, along with the information about accessories below, are some general guidelines to follow if loading cargo to your motorcycle:

The total weight of the operator, passenger, accessories and cargo must not exceed the maximum load limit.

Operation of an overloaded vehicle could cause an accident.

<p>Maximum load: 221 kg (487 lb)</p>

When loading within this weight limit, keep the following in mind:

- Cargo and accessory weight should be kept as low and close to the motorcycle as possible. Securely pack your heaviest items as close to the center of the vehicle as possible and make sure to distribute the weight as evenly as possible on both sides of the motorcycle to minimize imbalance or instability.
- Shifting weights can create a sudden imbalance. Make sure that ac-

cessories and cargo are securely attached to the motorcycle before riding. Check accessory mounts and cargo restraints frequently.

- Properly adjust the suspension for your load (suspension-adjustable models only), and check the condition and pressure of your tires.
- Never attach any large or heavy items to the handlebar, front fork, or front fender. These items, including such cargo as sleeping bags, duffel bags, or tents, can create unstable handling or a slow steering response.
- **This vehicle is not designed to pull a trailer or to be attached to a sidecar.**

Genuine Yamaha Accessories

Choosing accessories for your vehicle is an important decision. Genuine Yamaha accessories, which are available only from a Yamaha dealer, have been designed, tested, and approved by Yamaha for use on your vehicle.

Safety information

1

Many companies with no connection to Yamaha manufacture parts and accessories or offer other modifications for Yamaha vehicles. Yamaha is not in a position to test the products that these aftermarket companies produce. Therefore, Yamaha can neither endorse nor recommend the use of accessories not sold by Yamaha or modifications not specifically recommended by Yamaha, even if sold and installed by a Yamaha dealer.

Aftermarket Parts, Accessories, and Modifications

While you may find aftermarket products similar in design and quality to genuine Yamaha accessories, recognize that some aftermarket accessories or modifications are not suitable because of potential safety hazards to you or others. Installing aftermarket products or having other modifications performed to your vehicle that change any of the vehicle's design or operation characteristics can put you and others at greater risk of serious injury or death. You are responsible for injuries related to changes in the vehicle.

Keep the following guidelines in mind, as well as those provided under “Loading” when mounting accessories.

- Never install accessories or carry cargo that would impair the performance of your motorcycle. Carefully inspect the accessory before using it to make sure that it does not in any way reduce ground clearance or cornering clearance, limit suspension travel, steering travel or control operation, or obscure lights or reflectors.
- Accessories fitted to the handlebar or the front fork area can create instability due to improper weight distribution or aerodynamic changes. If accessories are added to the handlebar or front fork area, they must be as lightweight as possible and should be kept to a minimum.
- Bulky or large accessories may seriously affect the stability of the motorcycle due to aerodynamic effects. Wind may attempt to lift the motorcycle, or the motorcycle may become unstable in cross winds. These

accessories may also cause instability when passing or being passed by large vehicles.

- Certain accessories can displace the operator from his or her normal riding position. This improper position limits the freedom of movement of the operator and may limit control ability, therefore, such accessories are not recommended.
- Use caution when adding electrical accessories. If electrical accessories exceed the capacity of the motorcycle's electrical system, an electric failure could result, which could cause a dangerous loss of lights or engine power.

Aftermarket Tires and Rims

The tires and rims that came with your motorcycle were designed to match the performance capabilities and to provide the best combination of handling, braking, and comfort. Other tires, rims, sizes, and combinations may not be appropriate. See page 7-15 for tire specifications and for information on servicing and replacing your tires.

Transporting the Motorcycle

Be sure to observe following instructions before transporting the motorcycle in another vehicle.

- Remove all loose items from the motorcycle.
- Check that the fuel cock (if equipped) is in the off position and that there are no fuel leaks.
- Shift the transmission into gear (for models with a manual transmission).
- Secure the motorcycle with tie-downs or suitable straps that are attached to solid parts of the motorcycle, such as the frame or upper front fork triple clamp (and not, for example, to rubber-mounted handlebars or turn signals, or parts that could break). Choose the location for the straps carefully so the straps will not rub against painted surfaces during transport.
- The suspension should be compressed somewhat by the tie-downs, if possible, so that the motorcycle will not bounce excessively during transport.

Description

EAU10411

Left view

2

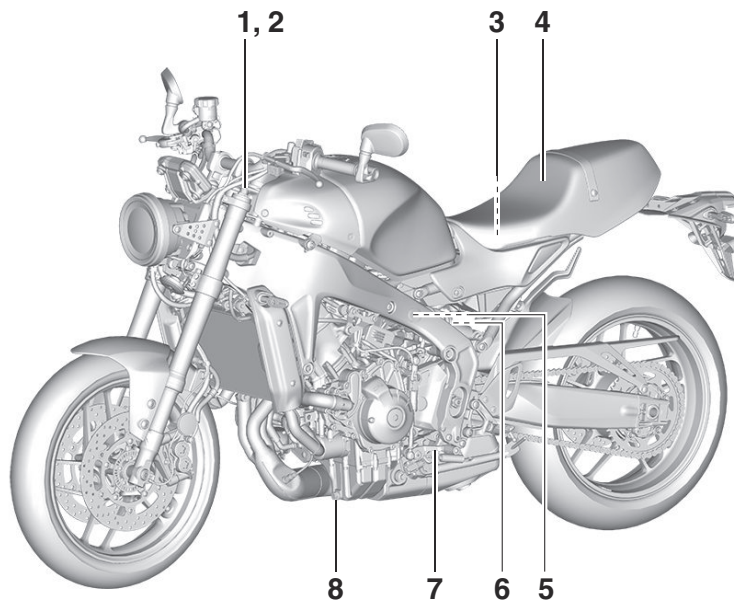

1. Spring preload adjuster (page 4-27)
2. Compression damping force adjuster (page 4-27)
3. Battery (page 7-29)
4. Seat (page 4-26)
5. Rebound damping force adjuster (page 4-30)
6. Spring preload adjuster (page 4-30)
7. Shift pedal (page 4-20)
8. Engine oil drain bolt (page 7-12)

Right view

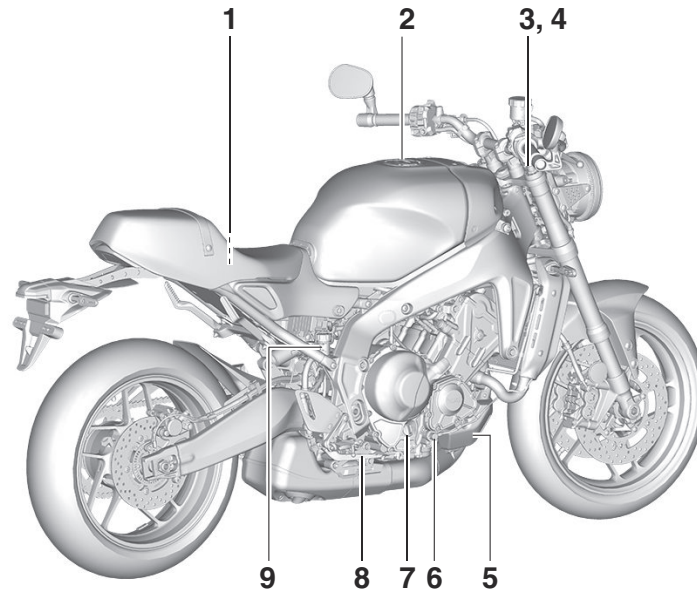

1. Fuses (page 7-31)
2. Fuel tank cap (page 4-23)
3. Spring preload adjuster (page 4-27)
4. Rebound damping force adjuster (page 4-27)
5. Coolant reservoir (page 7-13)
6. Engine oil level check window (page 7-12)
7. Engine oil filler cap (page 7-12)
8. Brake pedal (page 4-21)
9. Rear brake fluid reservoir (page 7-20)

Description

EAU10431

Controls and instruments

2

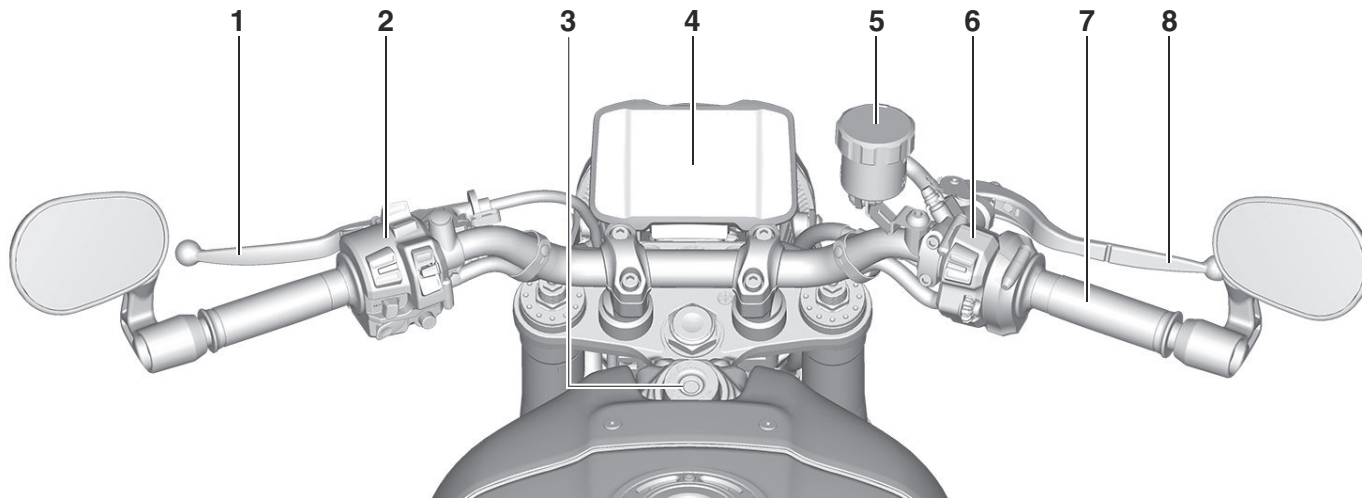

1. Clutch lever (page 4-19)
2. Left handlebar switches (page 4-3)
3. Main switch/steering lock (page 4-2)
4. Instrument panel (page 4-5, 4-9)
5. Front brake fluid reservoir (page 7-20)
6. Right handlebar switches (page 4-3)
7. Throttle grip

8. Brake lever (page 4-20)

Cruise control system

EAU98300

This model is equipped with a cruise control system designed to maintain a set cruising speed.

The cruise control system operates only when riding in 4th, 5th or 6th gear at speeds between about 50 km/h (31 mi/h) and 180 km/h (112 mi/h) or 140 km/h (87 mi/h) for 35kW restricted vehicles.



EWA21140

WARNING

- **Improper use of the cruise control system may result in loss of control, which could lead to an accident. Do not activate the cruise control system in heavy traffic, poor weather conditions, or among winding, slippery, hilly, rough or gravel roads.**
- **When traveling uphill or downhill, the cruise control system may not be able to maintain the set cruising speed.**
- **To prevent accidentally activating the cruise control system, turn it off when not in use. Make**

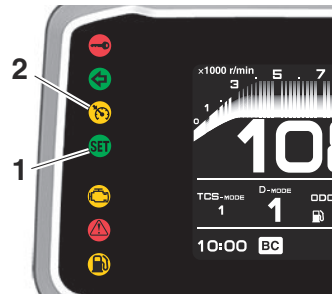
sure that the cruise control system indicator light “” is off.



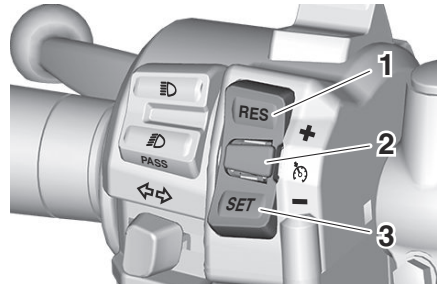

1. Cruise control setting indicator light “”
2. Cruise control system indicator light “”



1. Cruise control setting switch “RES+”
2. Cruise control power switch “”
3. Cruise control setting switch “SET-”

Activating and setting the cruise control system

1. Press the cruise control power switch “” located on the left handlebar. The cruise control system indicator light “” will come on.
2. Press the “SET-” side of the cruise control setting switch to activate the cruise control system. Your current traveling speed will become the set cruising speed. The cruise control setting indicator light “” will come on.

Adjusting the set cruising speed

While the cruise control system is operating, press the “RES+” side of the cruise control setting switch to increase the set cruising speed or the “SET-” side to decrease the set speed.

TIP

Pressing the setting switch once will change the speed in increments of approximately 2.0 km/h (1.2 mi/h). Holding the “RES+” or “SET-” side of the cruise control setting switch down will increase or decrease the speed

Special features

continuously until the switch is released.

You can also manually increase your traveling speed using the throttle. After you have accelerated, you can set a new cruising speed by pressing the “SET-” side of the setting switch. If you do not set a new cruising speed, when you return the throttle grip, the vehicle will decelerate to the previously set cruising speed.

Deactivating the cruise control system

Perform one of the following operations to cancel the set cruising speed. The “SET” indicator light will go off.

- Turn the throttle grip past the closed position in the deceleration direction.

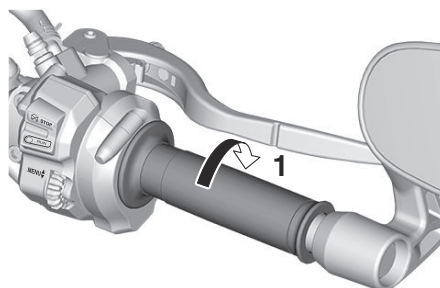

1. Deceleration direction

- Apply the front or rear brake.
- Disengage the clutch.
- Shift gears

Press the power switch to turn off the cruise control system. The “RES+” indicator light and the “SET” indicator light will go off.

TIP

Traveling speed decreases as soon as the cruise control system is deactivated; unless the throttle grip is turned.

Using the resume function

Press the “RES+” side of the cruise control setting switch to reactivate the cruise control system. The traveling speed will return to the previously set

cruising speed. The “SET” indicator light will come on.

EWA16351

WARNING

It is dangerous to use the resume function when the previously set cruising speed is too high for current conditions.

TIP

Pressing the power switch while the system is operating will turn the system off completely and erase the previously set cruising speed. You will not be able to use the resume function until a new cruising speed has been set.

Automatic deactivation of the cruise control system

The cruise control system for this model is electronically controlled and is linked with the other control systems. The cruise control system will automatically become deactivated under the following conditions:

- The cruise control system is not able to maintain the set cruising speed.

“D-MODE”

“D-MODE” is an electronically controlled engine performance system.



Do not change the drive mode while the vehicle is moving.



The “D-MODE” system consists of 4 different control maps which regulate engine response and output, thus providing you with a selection of modes to fit your preferences and the riding environment.



- D-MODE 1** - Sporty engine response
- D-MODE 2** - Moderate engine response
- D-MODE 3** - Mild engine response
- D-MODE 4** - Mild engine response and limits engine output

TIP

- 35kW restricted vehicles are limited to “D-MODE 1”.
- The current “D-MODE” setting is shown in the MODE display. (See page 4-12.)

- Wheel slip or wheel spin is detected. (If the traction control system has not been turned off, the traction control system will work.)
- The start/engine stop switch is set to the “” position.
- The engine stalls.
- The sidestand is lowered.

When traveling with a set cruising speed, if the cruise control system is deactivated under the above conditions, the “” indicator light will go off and the “” indicator light will flash for 4 seconds, and then go off.

When not traveling with a set cruising speed, if the start/engine stop switch is set to the “” position, the engine stalls, or the sidestand is lowered, then the “” indicator light will go off (the “” indicator light will not flash).

If the cruise control system is automatically deactivated, please stop and confirm that your vehicle is in good operating condition.

Before using the cruise control system again, activate it using the power switch.

TIP

In some cases, the cruise control system may not be able to maintain the set cruising speed when the vehicle is traveling uphill or downhill.

- When the vehicle is traveling uphill, the actual traveling speed may become lower than the set cruising speed. If this occurs, accelerate to the desired traveling speed using the throttle.
- When the vehicle is traveling downhill, the actual traveling speed may become higher than the set cruising speed. If this occurs, the setting switch cannot be used to adjust the set cruising speed. To reduce the traveling speed, apply the brakes. When the brakes are applied, the cruise control system will become deactivated.

Special features

3

- The current “D-MODE” setting is saved when the vehicle is turned off.
- The “D-MODE” is controlled by the MODE switches, see page 4-4 for more information.

EAU91434

“TCS-MODE”

This model is equipped with the traction control system (SCS), the slide control system (LIF), and the lift control system (LIF). These are grouped together into “TCS-MODE”. “TCS-MODE” has 4 settings:

MODE	Traction control system	SCS	LIF
TCS-MODE 1	1	1	1
TCS-MODE 2	2	2	2
TCS-MODE M	1, 2, 3	OFF, 1, 2, 3	OFF, 1, 2, 3
TCS-MODE OFF	OFF	OFF	OFF

“TCS-MODE M” is customizable in the settings MENU, see page 4-16.

Traction control system

The traction control system helps maintain traction when accelerating. If sensors detect that the rear wheel is starting to slip (uncontrolled spinning), the traction control system assists by regulating engine power as needed un-

til traction is restored. The stability control indicator light “sc” flashes to let the rider know that traction control has engaged.

This traction control system automatically adjusts according to the vehicle’s lean angle. To maximize acceleration, when the vehicle is upright a lesser amount of traction control is applied. When cornering, a greater amount of traction control is applied.



TIP

- The traction control system may engage when the vehicle travels over a bump.
- You may notice slight changes in engine and exhaust sounds when the traction control or other systems engage.

- The traction control system can only be turned off by setting “TCS-MODE” to “OFF”, using the MODE switches. See page 4-4 for more information on “TCS-MODE”.
- When “TCS-MODE” has been set to “OFF”, the traction control system, SCS and LIF systems are all turned off together.

EWA15433

WARNING

The traction control system is not a substitute for riding appropriately for the conditions. Traction control cannot prevent loss of traction due to excessive speed when entering turns, when accelerating hard at a sharp lean angle, or while braking, and cannot prevent front wheel slipping. As with any vehicle, approach surfaces that may be slippery with caution and avoid especially slippery surfaces.

When the vehicle power is on, the traction control system automatically turns on. The traction control system can be

turned on or off manually only when the key is in the “ON” position and the motorcycle is stopped.

TIP

Set “TCS-MODE” to “OFF” to help free the rear wheel if the motorcycle gets stuck in mud, sand, or other soft surfaces.

ECA16801

NOTICE

Use only the specified tires. (See page 7-15.) Using different sized tires will prevent the traction control system from controlling tire rotation accurately.

SCS

The slide control system regulates engine power output when a sideward slide is detected in the rear wheel. It adjusts power output based on data from the IMU (Inertial Measurement Unit). This system supports the traction control system to contribute to a smoother ride.

LIF

The lift control system reduces the rate at which the front wheel rises during extreme acceleration, such as during starts or out-of-corner exits. When front-wheel lift is detected, engine power is regulated to slow front-wheel lift while still providing good acceleration.

Special features

3

Quick shifter

EAU91341

The quick shifter allows for clutch lever-less, electronically-assisted shifting. When the sensor on the shift rod detects the appropriate motion in the shift pedal, engine power output is momentarily adjusted to allow for the gear change to occur.

The quick shifter does not operate when the clutch lever is pulled, therefore normal shifting can be done even when the quick shifter is set to on. Check the quick shifter indicator for current status and usability information.

Quick shifter usability	Indicator
Upshifting OK	QS ▲▼
Downshifting OK	QS ▲▼
Quick shifter cannot be used	QS ▲▼
Quick shifter turned off	QS ▲▼

Upshifting conditions

- Vehicle speed of at least 20 km/h (12 mi/h)

- Engine speed of at least 2200 r/min
- Accelerating (open throttle)

Downshifting conditions

- Vehicle speed of at least 20 km/h (12 mi/h)
- Engine speed of at least 2000 r/min
- Engine speed sufficiently away from red zone
- Decelerating and throttle fully-closed

TIP

- QS ▲ and QS ▼ can be individually set.
- Shifting into or out of neutral must be done using the clutch lever.

EAU91350

BC

The brake control system regulates hydraulic brake pressure for the front and rear wheels when the brakes are applied and wheel lock is detected. This system has two settings.

BC1 is standard ABS, which adjusts brake pressure based on vehicle speed and wheel speed data. BC1 is designed to engage and maximize braking when the vehicle is upright.

BC2 uses additional data from the IMU to regulate applied brake power when cornering to suppress lateral wheel slip.

BC1/BC2



BC2



BC2



ABS

EWA20891

 **WARNING**

The brake control system is not a substitute for the use of proper riding and braking techniques. The brake control system cannot prevent all loss of traction due to over-braking from excessive speed, or lateral wheel slip when braking on slippery surfaces.

Instrument and control functions

Immobilizer system

EAU1097B

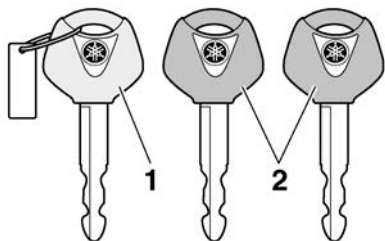

1. Code re-registering key (red bow)
2. Standard keys (black bow)

This vehicle is equipped with an immobilizer system to help prevent theft by re-registering codes in the standard keys. This system consists of the following:

- a code re-registering key
- two standard keys
- a transponder (in each key)
- an immobilizer unit (on the vehicle)
- an ECU (on the vehicle)
- a system indicator light (page 4-7)

About the keys

The code re-registering key is used to register codes in each standard key. Store the code re-registering key in a safe place. Use a standard key for daily operation.

When key replacement or re-registering is necessary, bring the vehicle and the code re-registering key along with any remaining standard keys to a Yamaha dealer to have them re-registered.

TIP

- Keep the standard keys as well as keys of other immobilizer systems away from the code re-registering key.
- Keep other immobilizer system keys away from the main switch as they may cause signal interference.

can still be used to start the vehicle. However, registering a new standard key is impossible. If all keys have been lost or damaged, the entire immobilizer system must be replaced. Therefore, handle the keys carefully.

- Do not submerge in water.
- Do not expose to high temperatures.
- Do not place near magnets.
- Do not place near items that transmit electrical signals.
- Do not handle roughly.
- Do not grind or alter.
- Do not disassemble.
- Do not put two keys of any immobilizer system on the same key ring.

ECA11823

NOTICE

DO NOT LOSE THE CODE RE-REGISTERING KEY! CONTACT YOUR DEALER IMMEDIATELY IF IT IS LOST! If the code re-registering key is lost, the existing standard keys

Main switch/steering lock

EAU10474

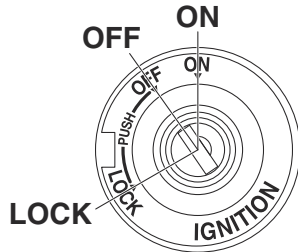

The main switch/steering lock controls the ignition and lighting systems, and is used to lock the steering. The various positions are described below.

TIP

Be sure to use the standard key (black bow) for regular use of the vehicle. To minimize the risk of losing the code re-registering key (red bow), keep it in a safe place and only use it for code re-registering.

ON

EAU84035

All electrical circuits are supplied with power and the vehicle lights are turned

on. The engine can be started. The key cannot be removed.

TIP

- The headlight(s) will turn on when the engine is started.
- To prevent battery drain, do not leave the key in the “ON” position without the engine running.

OFF

EAU10664

All electrical systems are off. The key can be removed.

⚠ WARNING

Never turn the key to “OFF” or “LOCK” while the vehicle is moving. Otherwise the electrical systems will be switched off, which may result in loss of control or an accident.

EWA10062

LOCK

EAU73810

The steering is locked and all electrical systems are off. The key can be removed.

To lock the steering

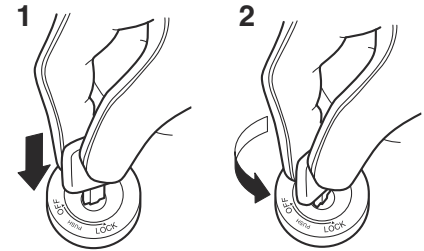

1. Push.
2. Turn.

1. Turn the handlebars all the way to the left or right.
2. With the key in the “OFF” position, push the key in and turn it to “LOCK”.
3. Remove the key.

TIP

If the steering will not lock, try turning the handlebars back to the right or left slightly.

Instrument and control functions

To unlock the steering

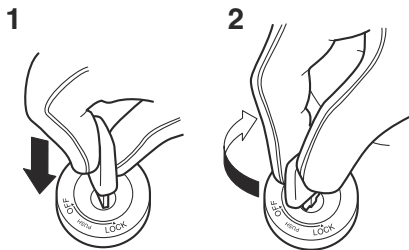

1. Push.
2. Turn.

Push the key in and turn it to “OFF”.

Handlebar switches

EAU66059

Left

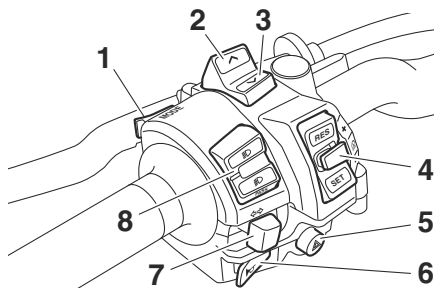

1. “MODE” switch
2. MODE up switch
3. MODE down switch
4. Cruise control switches
5. Hazard switch “ Δ ”
6. Horn switch “ 📢 ”
7. Turn signal switch “ \leftarrow/\rightarrow ”
8. Dimmer/Pass switch “ $\equiv\text{O}/\equiv\text{O}/\text{PASS}$ ”

Right

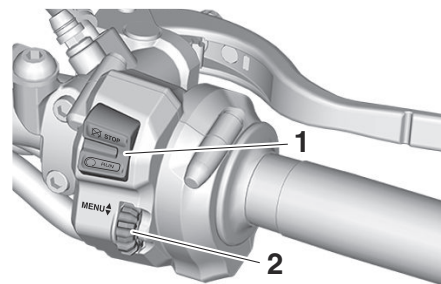

1. Stop/Run/Start switch “ $\text{X}/\text{O}/\text{S}$ ”
2. Wheel switch “MENU \blacklozenge ”

Dimmer/Pass switch “ $\equiv\text{O}/\equiv\text{O}/\text{PASS}$ ”

EAU91630

Set this switch to “ $\equiv\text{O}$ ” for the high beam and to “ $\equiv\text{O}$ ” for the low beam. While the headlight is set on low beam, push the switch down towards “PASS” to flash the high beam and to mark the start of each lap when using the lap timer.

Turn signal switch “ \leftarrow/\rightarrow ”

EAU66040

To signal a right-hand turn, push this switch to “ \rightarrow ”. To signal a left-hand

turn, push this switch to “↩”. When released, the switch returns to the center position. To cancel the turn signal lights, push the switch in after it has returned to the center position.

Horn switch “”

Press this switch to sound the horn.

EAU66030

Stop/Run/Start switch “”

To crank the engine with the starter, set this switch to “○”, and then push the switch down towards “⊗”. See page 6-2 for starting instructions prior to starting the engine.

Set this switch to “⊗” to stop the engine in case of an emergency, such as when the vehicle overturns or when the throttle cable is stuck.

EAU66061

Hazard switch “”

Use this switch to turn on the hazard lights (simultaneous flashing of all turn signal lights). The hazard lights are used in case of an emergency or to warn other drivers when your vehicle is

EAU91670

stopped where it might be a traffic hazard.

The hazard lights can be turned on or off only when the key is in the “ON” position. You can turn the main switch to the “OFF” or “LOCK” position, and the hazard lights will continue to flash. To turn off the hazard lights, turn the main switch to the “ON” position and operate the hazard switch again.

NOTICE

Do not use the hazard lights for an extended length of time with the engine not running, otherwise the battery may discharge.

ECA10062

Cruise control switches

See page 3-1 for an explanation of the cruise control system.

EAU73952

MODE switches

Use the MODE switches to change the “D-MODE” and “TCS-MODE” located on the left side of the main display.

EAU98320

There are three mode controls:

MODE up switch - press this switch to change the selected mode setting upward.

“MODE” switch - press this switch to toggle left to right between “D-MODE” and “TCS-MODE”.

MODE down switch - press this switch to change the selected mode setting downward.

TIP

- 35kW restricted vehicles are limited to “D-MODE 1”.
- When in “D-MODE 1”, pressing the MODE up switch will cycle to “D-MODE 4”. When in “D-MODE 4”, pressing the MODE down switch will not cycle to “D-MODE 1”.
- The “TCS-MODE” can only be turned off from the main display. Select “TCS-MODE” with the “MODE” switch, then press and hold the MODE up switch until “OFF” is displayed.
- To turn the traction control system back on, use the MODE down switch.

Instrument and control functions

- When “TCS-MODE” has been set to “OFF”, the traction control system, SCS and LIF systems are all turned off together.
- See page 4-12 for more information on the MODE display.
- See page 3-4 for more information on “TCS-MODE”.
- See page 3-3 for more information on “D-MODE”.

Wheel switch “MENU”

EAU91374

When the wheel switch is operated, a cursor will appear around the previously selected item on the display.

The wheel switch controls:

- Vehicle information displays
- Settings MENU
- Grip warmer function (Option)

Operate the wheel switch as follows:

Rotate up - rotate the wheel upward to scroll up or increase a setting value.

Rotate down - rotate the wheel downward to scroll down or decrease a setting value.

Press inward - press the wheel switch in towards the handlebar to select

items indicated by the cursor and confirm settings changes. Press and hold the switch inward to reset selected items.

TIP

- If the wheel switch is not operated for a certain period of time, the cursor will disappear.
- For items that can be reset, leave the cursor over the item, press and hold the switch to reset.
- See page 4-9 for more information on the main screen and its functions.
- See page 4-15 for more information on the MENU screen and how to make settings changes.

Indicator lights and warning lights

EAU4939Y

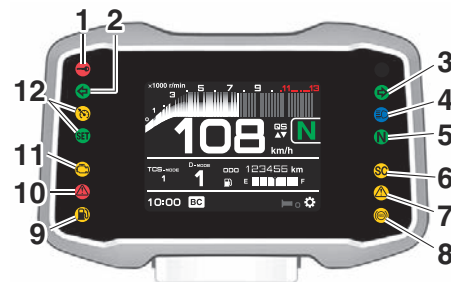

1. Immobilizer system indicator light “”
2. Left turn signal indicator light “”
3. Right turn signal indicator light “”
4. High beam indicator light “”
5. Neutral indicator light “”
6. Stability control indicator light “”
7. Auxiliary system warning light “”
8. ABS warning light “”
9. Fuel level warning light “”
10. Oil pressure and Coolant temperature warning light “”
11. Malfunction indicator light “”
12. Cruise control indicator lights “” / “”

Turn signal indicator lights “” and “”

EAU88280

Each indicator light will flash when its corresponding turn signal lights are flashing.

Neutral indicator light “”

EAU88300

This indicator light comes on when the transmission is in the neutral position.

High beam indicator light “”

EAU88310

This indicator light comes on when the high beam of the headlight is switched on.

Fuel level warning light “”

EAU88320

This warning light comes on when the fuel level drops below approximately 2.7 L (0.71 US gal, 0.59 Imp.gal). When this occurs, refuel as soon as possible. The electrical circuit of the warning light can be checked by turning the vehicle on. The warning light should come on for a few seconds, and then go off.

TIP

If the warning light does not come on at all, remains on after refueling, or if the warning light flashes repeatedly, have a Yamaha dealer check the vehicle.

Cruise control indicator lights “”/ “”

EAU91650

These indicator lights come on when the cruise control system is activated. (See page 3-1.)

TIP

When the vehicle is turned on, these lights should come on for a few seconds and then go off. Otherwise, have a Yamaha dealer check the vehicle.

Malfunction indicator light (MIL)

EAU88331

“”

This light comes on or flashes if a problem is detected in the engine or other vehicle control system. If this occurs, have a Yamaha dealer check the on-board diagnostic system. The electrical circuit of the warning light can be checked by turning the vehicle power

on. The light should come on for a few seconds, and then go off. If the light does not come on initially when the vehicle power is turned on, or if the light remains on, have a Yamaha dealer check the vehicle.

ECA26820

NOTICE

If the MIL starts flashing, reduce engine speed to prevent exhaust system damage.

TIP

The engine is sensitively monitored by the on-board diagnostic system to detect deterioration or malfunction of the emission control system. Therefore the MIL may come on or flash due to vehicle modifications, lack of maintenance, or excessive/improper use of the motorcycle. To prevent this, observe these precautions.

- Do not attempt to modify the software of the engine control unit.
- Do not add any electrical accessories that interfere with engine control.
- Do not use aftermarket accessories or parts such as suspension,

Instrument and control functions

spark plugs, injectors, exhaust system, etc.

- Do not change the drivetrain specifications (chain, sprockets, wheels, tires, etc.).
- Do not remove or alter the O2 sensor, air induction system, or exhaust parts (catalysts or EXUP, etc.).
- Maintain the drive chain properly.
- Maintain correct tire pressure.
- Maintain proper brake pedal height to prevent rear brake from dragging.
- Do not operate the vehicle in an extreme manner. For example, repeated or excessive opening and closing of the throttle, racing, burnouts, wheelies, extended half-clutch use, etc.

ABS warning light “”

EAU91500

In normal operation, the ABS warning light comes on when the vehicle is turned on, and goes off after traveling at a speed of 5 km/h (3 mi/h) or higher.

TIP _____

If the warning light does not work as described above, or if the warning light comes on while riding, the ABS may not work correctly. Have a Yamaha dealer check the vehicle as soon as possible.

EWA21120

WARNING _____

If the ABS warning light does not turn off after reaching 5 km/h (3 mi/h), or if the warning light comes on while riding:

- **Use extra caution to avoid possible wheel lock during emergency braking.**
- **Have a Yamaha dealer check the vehicle as soon as possible.**

EAU88350

Immobilizer system indicator light



When the main switch is turned off and 30 seconds have passed, the indicator light will flash steadily to indicate the immobilizer system is enabled. After 24 hours have passed, the indicator light will stop flashing, however the immobilizer system is still enabled.

TIP _____

When the vehicle is turned on, this light should come on for a few seconds and then go off. If the light does not come on, or if the light remains on, have a Yamaha dealer check the vehicle.

Transponder interference

If the immobilizer system indicator light flashes in the pattern, slowly 5 times then quickly 2 times, this could be caused by transponder interference. If this occurs, try the following.

1. Make sure there are no other immobilizer keys close to the main switch.
2. Use the code re-registering key to start the engine.
3. If the engine starts, turn it off, and try starting the engine with the standard keys.
4. If one or both of the standard keys do not start the engine, take the vehicle and all 3 keys to a Yamaha dealer to have the standard keys re-registered.

Stability control indicator light “SC”

EAU91472

This indicator light flashes when the traction control system, SCS, or LIF systems engage while riding. When “TCS-MODE” is set to “OFF”, the indicator will come on.

TIP

When the vehicle is turned on, this light should come on for a few seconds and then go off. If the light does not come on, or if the light remains on, have a Yamaha dealer check the vehicle.

NOTICE

ECA27222

When turning the main switch on, avoid any movement or vibration of the vehicle as it may interfere with the initialization of the IMU. If this occurs, the traction control system will not operate and the “TCS-MODE” display will read “OFF” until the IMU can initialize.

Oil pressure and Coolant temperature warning light “”

EAU88362

This warning light comes on if the engine oil pressure is low or if the coolant temperature is high. If this occurs, stop the engine immediately.

TIP

- When the vehicle is first turned on, this light should come on until the engine is started.
- If a malfunction is detected, this light will come on and the oil pressure icon will flash.

NOTICE

ECA22441

If the oil pressure and coolant warning light does not go off after starting the engine or if it comes on while the engine is running, stop the vehicle and engine immediately.

- If the engine is overheating, the coolant temperature warning icon will come on. Let the engine cool. Check the coolant level (see page 7-36).
- If the engine oil pressure is low, the oil pressure warning icon

will come on. Check the oil level (see page 7-12).

- **If the warning light remains on after letting the engine cool and confirming the proper oil level, have a Yamaha dealer check the vehicle. Do not continue to operate the vehicle!**

Auxiliary system warning light “”

EAU88370

This warning light comes on if a problem is detected in a non-engine-related system.

TIP

When the vehicle is turned on, this light should come on for a few seconds and then go off. Otherwise, have a Yamaha dealer check the vehicle.

Instrument and control functions

EAU96242

Display

The following items can be found on the display:

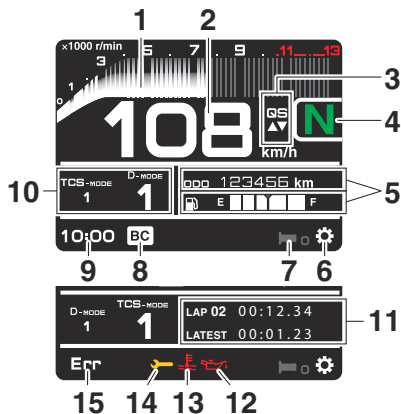

1. Tachometer
2. Speedometer
3. Quick shifter indicator “QS”
4. Transmission gear display
5. Vehicle information displays
6. Settings MENU icon “⚙️”
7. Grip warmer indicator (option)
8. Brake control icon “BC”
9. Clock
10. MODE display
11. Lap timer

12. Oil pressure warning “”
13. Coolant temperature warning “”
14. Auxiliary system warning “”
15. Error mode warning “Err” (replaces clock when activated)

TIP

This model uses a thin-film-transistor liquid-crystal display (TFT LCD) for good contrast and readability in various lighting conditions. However, due to the nature of this technology, it is normal for a small number of pixels to be inactive.

EWA18210

WARNING

Stop the vehicle before making any setting changes. Changing settings while riding can distract the operator and increase the risk of an accident.

Speedometer

The speedometer shows the vehicle’s traveling speed.

TIP

The display can be switched between kilometers and miles. See “Unit” on page 4-18.

Tachometer

The tachometer shows the engine speed, as measured by the rotational velocity of the crankshaft, in revolutions per minute (r/min).

ECA10032

NOTICE

Do not operate the engine in the tachometer red zone.

Red zone: 10600 r/min and above

Vehicle information displays

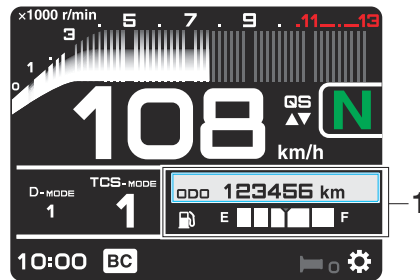

1. Vehicle information displays

Instrument and control functions

The two vehicle information displays can be individually set to show the following items:

- ODO: odometer
- F-TRIP: fuel reserve tripmeter
- TRIP1: tripmeter
- TRIP2: tripmeter
- F.AVE: average fuel economy
- F.CRNT: instantaneous fuel economy
- A.TEMP: air temperature
- C.TEMP: coolant temperature
- Fuel meter
- FUEL CON: amount of fuel consumed
- TRIP TIME: running time

Operate the vehicle information display as follows:

Rotate the wheel switch to move the cursor over a display.

Press the wheel switch inward and the selected display will highlight grey.

Rotate the wheel switch to choose a different display item.

Press the wheel switch inward to confirm the new display item.

TIP

- In LAP TIME mode, the vehicle information display is replaced by the lap information.
- TRIP1, TRIP2, F-TRIP, F.AVE, FUEL CON and TRIP TIME items can be individually reset.

Odometer:



ODO 123456 km

The odometer shows the total distance traveled by the vehicle.

TIP

ODO will lock at 999999 and cannot be reset.

Fuel reserve tripmeter:



F-TRIP 20.0 km

When the fuel tank reserve level has been reached, F-TRIP appears automatically and begins recording distance traveled from that point.

After refueling and traveling some distance, F-TRIP will automatically disappear.

Tripmeters:

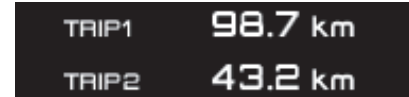

TRIP1 98.7 km
TRIP2 43.2 km

TRIP1 and TRIP2 show the distance traveled since they were last set to zero.

TIP

TRIP1 and TRIP2 will reset to 0 and begin counting again after 9999.9 has been reached.

Average fuel economy:



F.AVE 8.7 km/L

The average fuel economy display can be set to “km/L” or “L/100km”. See page 4-18.

Instrument and control functions

TIP
After resetting the average fuel economy display, "--." will be shown until the vehicle has traveled 1 km.

Instantaneous fuel economy:



The instant fuel economy display can be set to "km/L" or "L/100km". See page 4-18.

TIP

- If traveling at speeds under 10 km/h, "--." will be displayed.
- The instantaneous fuel economy function should be used for general reference only. Do not use this figure to estimate the distance that can be traveled on the current tank of fuel.

Air temperature:



The air temperature is displayed from $-9\text{ }^{\circ}\text{C}$ ($16\text{ }^{\circ}\text{F}$) to $50\text{ }^{\circ}\text{C}$ ($122\text{ }^{\circ}\text{F}$) in $1\text{ }^{\circ}\text{C}$ ($1\text{ }^{\circ}\text{F}$) increments. The temperature displayed may vary from the actual ambient temperature.

TIP

- "--" will be displayed if the detected temperature is lower.
- "--" will be displayed if the detected temperature is higher.

Coolant temperature:



The coolant temperature is displayed from $40\text{ }^{\circ}\text{C}$ ($104\text{ }^{\circ}\text{F}$) to $124\text{ }^{\circ}\text{C}$ ($255\text{ }^{\circ}\text{F}$) in $1\text{ }^{\circ}\text{C}$ ($1\text{ }^{\circ}\text{F}$) increments.

TIP

- If the vehicle coolant temperature is below $40\text{ }^{\circ}\text{C}$ ($104\text{ }^{\circ}\text{F}$) the coolant temperature display will read "Lo"
- If the vehicle coolant temperature is above $124\text{ }^{\circ}\text{C}$ ($255\text{ }^{\circ}\text{F}$) the coolant temperature display will read "Hi"

Fuel Meter:



The fuel meter indicates the amount of fuel in the fuel tank. The display segments of the fuel meter disappear from "F" (full) towards "E" (empty) as the fuel level decreases. When the last segment starts flashing, refuel as soon as possible.

ECAE0121

NOTICE

Do not let the vehicle run completely out of fuel. This may cause damage to the catalytic converter.

Fuel consumption trip meter:



Displays how much fuel has been consumed since the trip meter was last reset.

Instrument and control functions

Trip time:



Displays engine running time.

To reset information display items

1. Rotate the wheel switch to select one of the two vehicle information displays.
2. Press the wheel switch inward to highlight the information display.
3. Rotate the wheel switch to select the desired information display item.
4. Press and hold the wheel switch inward until the highlighted display item is reset.

Transmission gear display

This shows which gear the transmission is in. This model has 6 gears and a neutral position. The neutral position is indicated by the neutral indicator light “N” and by the transmission gear display “N”.

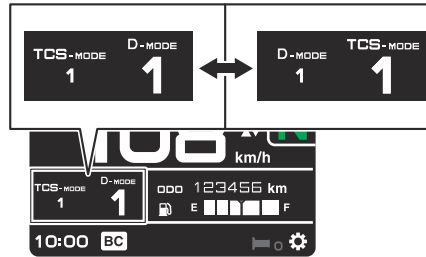

MODE display



This display shows the currently selected “D-MODE” and “TCS-MODE” settings. The mode that is enlarged and displayed on the right can be adjusted using the MODE up/down switches. Use the “MODE” switch to toggle left-right between “TCS-MODE” and “D-MODE”.

See page 3-3 for information on “D-MODE” and “TCS-MODE” settings.

TIP

- When the malfunction indicator light “”, the auxiliary system warning “”, or the coolant temperature warning “” are on, “D-MODE” and “TCS-MODE” cannot be adjusted.

- The previously selected modes will be displayed when the vehicle power is turned on.

To turn off the traction control system, select “TCS-MODE” with the “MODE” switch, then press and hold the MODE up switch until “OFF” is displayed. To turn the traction control system back on, press the MODE down switch (“TCS-MODE” will return to its previous setting).

TIP

- When “TCS-MODE” has been set to “OFF”, the traction control system, SCS and LIF systems are all turned off together.
- The “TCS-MODE OFF” and “TCS-MODE M” settings can only be selected while the vehicle is stopped.

Clock

The clock uses a 12-hour time system. See page 4-19 to set the clock.

Instrument and control functions

Quick shifter indicator “QS”

When able to shift, the respective QS ▲ or ▼ turns green.

When unable to shift, QS △ ▽ is white.

If the quick shifter function is turned OFF, QS △ ▽ itself is not displayed.

The quick shifter functions can be turned on or off in the setting MENU. See page 4-16.

TIP

The upshift and downshift functions are independent and can be activated separately.

For more information on the quick shifter see “Quick shifter” on page 3-6.

Setting menu icon “⚙️”

Choose this icon and press the wheel switch inward to change the settings MENU screen. (See page 4-15.)

Grip warmer indicator (Option)

The grip warmers can be used when the engine is running. There are 10 temperature levels. When activated, the indicator will display the temperature level from 1 (lowest) to 10 (highest).

To activate the grip warmer, use the wheel switch to highlight the grip warmer display with the cursor.

Press the wheel switch inward to select the grip warmer function.

Once selected, rotate the wheel switch up and down to adjust the temperature level.

Press the wheel switch inward to confirm the temperature level and exit the grip warmer function.

ECA17932

NOTICE

- **Be sure to wear gloves when using the grip warmers.**
- **Do not use the grip warmers in warm weather.**
- **If the handlebar grip or throttle grip becomes worn or damaged, stop using the grip warmers and replace the grips.**

The function of the wheel switch can be locked into grip warmer mode by pressing and holding the wheel switch inward while the grip warmer indicator is highlighted by the cursor.

In this mode, the temperature levels can be instantly adjusted by rotating the wheel switch up/down.

To exit this mode and return the wheel switch to its normal functionality, press and hold the wheel switch inward.

TIP

The current grip warmer setting is saved when the vehicle is turned off.

Lap timer

This stopwatch function can be activated through the setting MENU. (See page 4-15.)

Once activated, the vehicle information display is replaced with:



1. Lap count
2. Current lap time

3. Latest/Previous lap time

To start the timer, press the dimmer/pass switch down towards “PASS”.

Each press of the dimmer/pass switch will increase the lap count by 1 and reset the current lap timer.

To pause the lap timer, press the wheel switch inward.

To unpause the timer, press the dimmer/pass switch down towards “PASS” and the timer will resume without counting a new lap.

To exit the lap time mode, turn it off in the settings MENU. (See page 4-15.)

TIP

- The engine must be running to start the lap timer.
- The headlight will flash when the dimmer/pass switch is pressed.
- Whenever the lap timer is paused, it can be resumed using the dimmer/pass switch.

Brake control icon “BC”

This icon is replaced by the auxiliary system warning and coolant tempera-

ture warning indicators when they are activated.

For more information on the BC system see “BC” on page 3-6.

Error mode warning “Err”

When an internal error occurs (e.g., communication with a system controller has been cut off), the error mode warning will appear as follows.

“Err” and “

“Err” only indicates an ABS ECU error.

TIP

Depending on the nature of the error, the display may not function properly and the traction control system settings may be impossible to change. Additionally, ABS may not function properly. Use extra care when braking and have a Yamaha dealer check the vehicle immediately.

Auxiliary system warning “ This icon appears if a problem is detected in a non-engine-related system.

Coolant temperature warning “ This icon appears if the coolant temperature reaches 116 °C (241 °F) or higher. Stop the vehicle and turn off the engine. Allow the engine to cool.

ECA10022

NOTICE

Do not continue to operate the engine if it is overheating.

4

Oil pressure warning “ This icon appears when the engine oil pressure is low. When the vehicle is first turned on, engine oil pressure has yet to build, so this icon will come on and stay on until the engine has been started.

TIP

If a malfunction is detected, the oil pressure warning icon will flash repeatedly.

ECA26410

NOTICE

Do not continue to operate the engine if the oil pressure is low.

Instrument and control functions

EAU9145C

Settings MENU

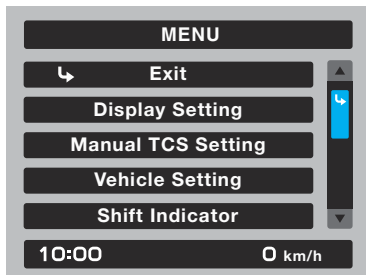

The settings MENU screen contains the following settings modules. Select a module to make related settings changes.

Module	Description
“Exit”	Exit MENU and return the main display
“Display Setting”	Switch lap time mode on/off and adjust the tachometer color
“Manual TCS Setting”	Adjust traction control system/SCS/LIF settings for the “TCS-MODE M”
“Vehicle Setting”	Adjust BC/quick shifter settings
“Shift Indicator”	Turn the shift indicator on/off and adjust tachometer settings

Module	Description
“Maintenance”	View and reset maintenance intervals
“Unit”	Set fuel consumption and measurement units
“Brightness”	Adjust screen brightness
“Clock”	Adjust the clock
“All Reset”	Return all settings to factory default

Settings MENU access and operation

How to use the settings MENU: Rotate the wheel switch up or down to highlight items or increase/decrease values and briefly press the wheel switch inward to confirm the selection. Press and hold the wheel switch until the screen returns to the main display to exit the MENU at any time.

TIP

- Certain settings menu screens have an upward pointing triangle mark item. Select the triangle mark to save settings changes and exit the current screen.
- Should vehicle motion be detected, the screen will automatically

exit the settings MENU and return to the main display.

- To ensure that the desired settings changes are saved, be sure to exit each menu via the triangle mark (if displayed). Exiting the settings menu by pressing and holding the wheel switch may not save settings changes.

“Display Setting”

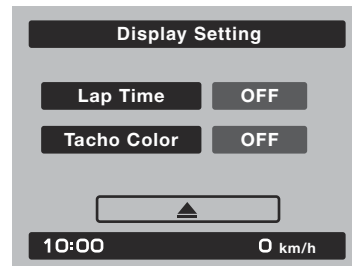

This module allows you to switch the lap time mode and tachometer color mode ON/OFF.

When the lap time mode is selected, the twin vehicle information displays on the main screen will display a lap timer and a lap counter. To exit the lap time

mode, the turn lap timer OFF in the display setting module.

To change the tachometer to color mode, select ON.

“Manual TCS Setting”

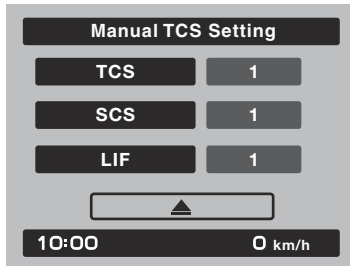

This module allows you to customize the “TCS-MODE M” which is accessible on the main display using the MODE switches.

Traction control system

This model uses a variable traction control system. For each setting level, the further the vehicle is leaned over, the greater the amount of traction control (system intervention) is applied.

There are 3 setting levels available for the “TCS-MODE M”.

Setting level 1 applies the least amount of overall system intervention, while setting level 3 applies the greatest amount of overall traction control.

TIP

- The traction control system can only be turned on or off via the main screen using the MODE switches.
- SCS and LIF can be turned off independently of traction control system for “TCS-MODE M”.
- When “TCS-MODE” has been set to “OFF” on the main screen: traction control system, SCS and LIF are all turned off together.

SCS

SCS can be set to OFF, 1, 2, and 3.

OFF turns the slide control system off, setting level 1 provides the least amount of system intervention, and setting level 3 provides the greatest amount of system intervention.

LIF

LIF can be set to OFF, 1, 2, and 3.

Setting level 1 provides the least amount of system intervention and setting 3 most strongly reduces the rate of wheel lift.

OFF turns LIF off.

“Vehicle Setting”

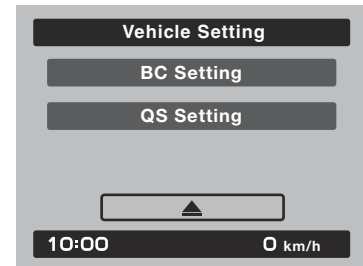

The vehicle setting module allows you to adjust setting for the BC and quick shifter.

Instrument and control functions

BC

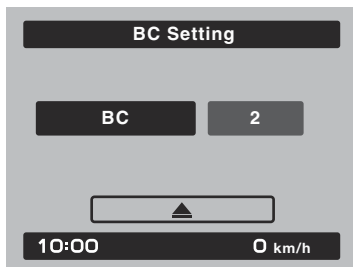

The brake control system has two settings, BC1 and BC2. Select BC1 when only standard ABS is desired. Select BC2 to have the brake control system further regulate brake pressure while cornering to suppress lateral wheel slip.

TIP

For skilled riders and when riding at the track, due to varying conditions, the BC2 brake system may engage sooner than expected relative to your desired cornering speed or intended cornering line.

Quick shifter

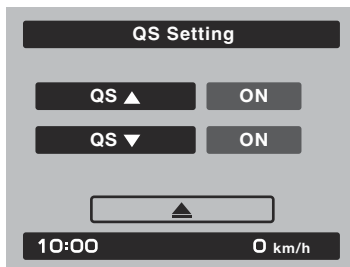

The quick shifter indicators are divided into QS▲ and QS▼ sections. QS▲ and QS▼ are not linked and can be independently turned on or off.

The quick shifter can be set to ON or OFF.

OFF turns the respective upshift or downshift function off, and the clutch lever must then be used when shifting in that direction.

TIP

If the quick shifter setting cannot be changed: turn the engine off with the gear position set to neutral, then change the setting.

“Shift Indicator”

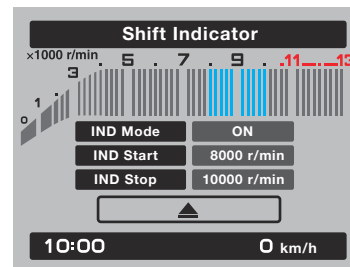

This module allows a custom shift indicator to be set. When the engine r/min (rotations per minute) are in the specified range, the gear indicator will flash.

This module has 3 options:

“IND Mode” - the shift indicator can be turned ON/OFF

“IND Start” - the r/min at which the indicator starts flashing can be chosen. Once selected, rotate the wheel switch up/down to increase or decrease the r/min value by increments of 200 r/min.

“IND Start” is settable between 6000 - 12800 r/min.

“IND Stop” - the r/min at which the indicator stops flashing can be chosen. Once selected, rotate the wheel switch up/down to increase or decrease the

r/min value by increments of 200 r/min. “IND Stop” is settable between 6200 - 13000 r/min.

“Maintenance”

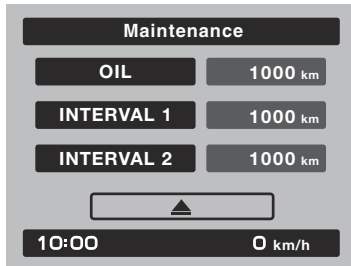

This module allows you to record the distance traveled between engine oil changes (use the OIL item), and for two other items of your choice (use INTERVAL 1 and INTERVAL 2).

To reset a maintenance trip meter, select it and then press and hold the wheel switch.

TIP _____

Maintenance item names cannot be changed.

“Unit”

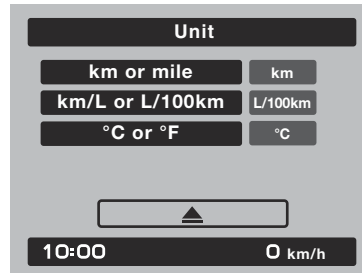

This module allows you to switch the display between metric and imperial measurement units.

When using kilometers, the fuel consumption units can be changed between “km/L” or “L/100km”. When using miles, MPG will be available.

Temperature units can be switched between Celsius and Fahrenheit.

“Brightness”

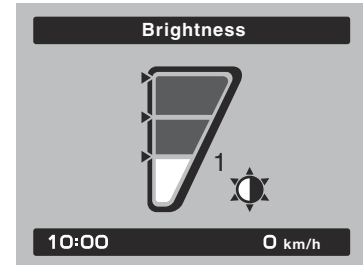

This module allows you to adjust the general brightness level of the display screen.

Select the desired brightness level by rotating the wheel switch, and then press the wheel switch to fix the setting and return to the top MENU screen.

Instrument and control functions

EAU12823

“Clock”



This module allows you to set the clock.

When the clock module is selected, the hours will be highlighted.

Set the hours by rotating the wheel switch. Press the wheel switch inward to confirm and highlight the minutes.

After confirming the minutes, you will be returned to the top MENU screen.

“All Reset”

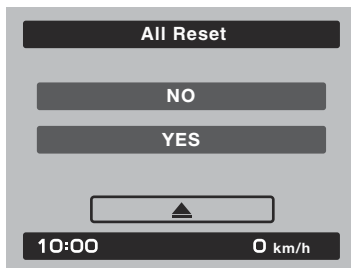

This module resets all settings items (except the odometer and clock) to their default or factory presets.

Select YES to reset all items. After selecting YES, all items will be reset and the screen will automatically return to the top MENU screen.

Clutch lever

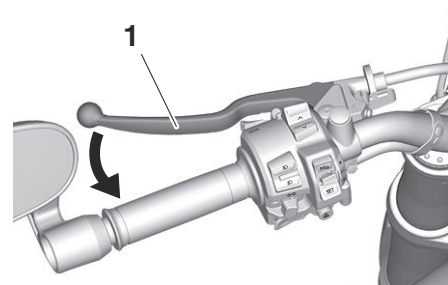

1. Clutch lever

To disengage the drivetrain from the engine, such as when shifting gears, pull the clutch lever toward to the handlebar. Release the lever to engage the clutch and transmit power to the rear wheel.

TIP

The lever should be pulled rapidly and released slowly for smooth shifting. (See page 6-3.)

EAU83692

Shift pedal

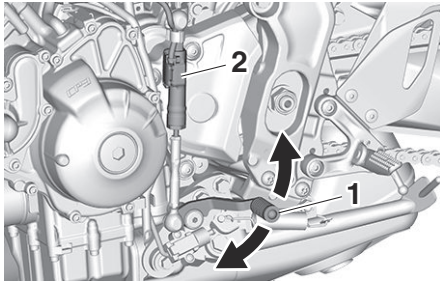

1. Shift pedal
2. Shift sensor

The shift pedal is located on the left side of the motorcycle. To shift the transmission to a higher gear, move the shift pedal up. To shift the transmission to a lower gear, move the shift pedal down. (See page 6-3.)

The shift rod is equipped with a shift sensor, which is part of the quick shifter. The shift sensor reads up and down movement, as well as the strength of the input force when the shift pedal is moved.

TIP

To prevent unintended shifts, the quick shifter is programmed to ignore unclear input signals. Therefore, be sure to shift using quick and sufficiently forceful inputs.

EAU93083

Brake lever

The brake lever is located on the right side of the handlebar. To apply the front brake, pull the lever toward the throttle grip.

Adjusting the brake lever

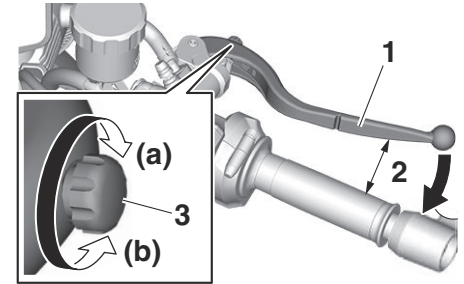

1. Brake lever
2. Distance
3. Brake lever position adjusting knob

To adjust the distance between the brake lever and the handlebar, gently push the lever away from the handlebar and rotate the brake lever position adjusting knob.

Instrument and control functions

Turn the adjusting knob in direction (a) to increase the distance. Turn the adjusting knob in direction (b) to decrease the distance.

4

Brake pedal

EAU12944

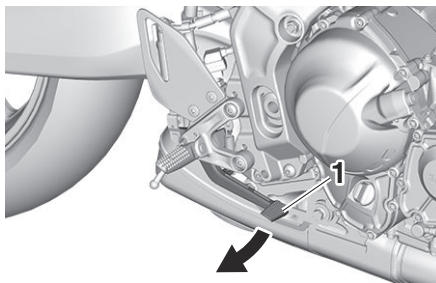

1. Brake pedal

The brake pedal is located on the right side of the motorcycle. To apply the rear brake, press down on the brake pedal.

EAU91461

Brake control system (BC)

The brake control system regulates hydraulic brake pressure for the front and rear wheels independently when the brakes are applied and wheel lock is detected. This system has two settings which can be changed in the settings MENU. (See page 4-16.)

BC1 is standard ABS, which adjusts brake pressure based on vehicle speed and wheel speed data. BC1 is designed to engage and maximize braking when the vehicle is upright. BC2 uses additional data from the IMU to regulate applied brake power when cornering to suppress lateral wheel slip.

Regarding ABS, operate the brakes as you would conventional brakes. When the brake control system engages, a pulsating sensation may be felt at the brake lever or brake pedal as the hydraulic unit rapidly applies and reduces brake pressure. In this situation, continue to apply the brake lever and brake pedal to allow the ABS to work—do not “pump the brakes” as this will reduce braking effectiveness.

WARNING

EWA16051

Always keep a sufficient distance from the vehicle ahead to match the riding speed even with ABS.

- The ABS performs best with long braking distances.
- On certain surfaces, such as rough or gravel roads, the braking distance may be longer with the ABS than without.

The ABS hydraulic unit is monitored by the ABS ECU, which will revert the system to conventional braking if a malfunction occurs.

EWA20891

WARNING

The brake control system is not a substitute for the use of proper riding and braking techniques. The brake control system cannot prevent all loss of traction due to over-braking from excessive speed, or lateral wheel slip when braking on slippery surfaces.

TIP

The ABS performs a self-diagnostic test when the vehicle is started and reaches a speed of 5 km/h (3 mi/h). During this test, a clicking noise may be audible from the hydraulic control unit, and a vibration may be felt at the brake lever or pedal, but this is normal.

ECA20100

NOTICE

Be careful not to damage the wheel sensor or wheel sensor rotor; otherwise, improper performance of the ABS will result.



1. Front wheel sensor rotor
2. Front wheel sensor

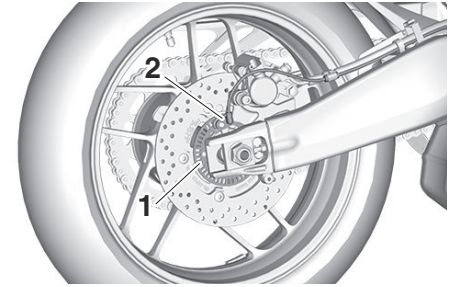

1. Rear wheel sensor rotor
2. Rear wheel sensor

Instrument and control functions

Fuel tank cap

EAU13077



1. Fuel tank cap lock cover
2. Unlock.

To open the fuel tank cap

Open the fuel tank cap lock cover, insert the key, and then turn it 1/4 turn clockwise. The lock will be released and the fuel tank cap can be opened.

To close the fuel tank cap

With the key still inserted, push down the fuel tank cap. Turn the key 1/4 turn counterclockwise, remove it, and then close the lock cover.

TIP

The fuel tank cap cannot be closed unless the key is in the lock. In addition,

the key cannot be removed if the cap is not properly closed and locked.

EWA11092

WARNING

Make sure that the fuel tank cap is properly closed after filling fuel. Leaking fuel is a fire hazard.

EAU13222

Fuel

Make sure there is sufficient gasoline in the tank.

EWA10882

WARNING

Gasoline and gasoline vapors are extremely flammable. To avoid fires and explosions and to reduce the risk of injury when refueling, follow these instructions.

1. Before refueling, turn off the engine and be sure that no one is sitting on the vehicle. Never refuel while smoking, or while in the vicinity of sparks, open flames, or other sources of ignition such as the pilot lights of water heaters and clothes dryers.
2. Do not overfill the fuel tank. When refueling, be sure to insert the pump nozzle into the fuel tank filler hole. Stop filling when the fuel reaches the bottom of the filler tube. Because fuel expands when it heats up, heat from the engine or the sun can cause fuel to spill out of the fuel tank.

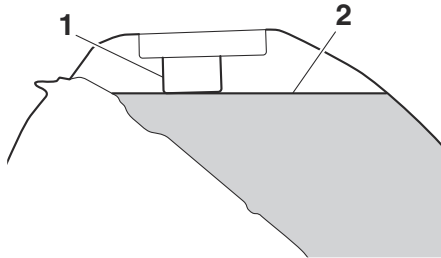

1. Fuel tank filler tube
2. Maximum fuel level
3. Wipe up any spilled fuel immediately. **NOTICE: Immediately wipe off spilled fuel with a clean, dry, soft cloth, since fuel may deteriorate painted surfaces or plastic parts.** [ECA10072]
4. Be sure to securely close the fuel tank cap.

EWA15152



WARNING

Gasoline is poisonous and can cause injury or death. Handle gasoline with care. Never siphon gasoline by mouth. If you should swallow some gasoline or inhale a lot of gasoline vapor, or get some gasoline in

your eyes, see your doctor immediately. If gasoline spills on your skin, wash with soap and water. If gasoline spills on your clothing, change your clothes.

EAU86072

Your Yamaha engine was designed to use unleaded gasoline with a research octane number of 95 or higher. If engine knocking or pinging occurs, use a gasoline of a different brand or higher octane rating.

Recommended fuel:
Unleaded gasoline (E10 acceptable)
Octane number (RON):
95
Fuel tank capacity:
14 L (3.7 US gal, 3.1 Imp.gal)
Fuel tank reserve:
2.7 L (0.71 US gal, 0.59 Imp.gal)



TIP

- This mark identifies the recommended fuel for this vehicle as specified by European regulation (EN228).
- Confirm the gasoline pump nozzle has the same fuel identification mark.

Gasohol

There are two types of gasohol: gasohol containing ethanol and that containing methanol. Gasohol containing ethanol can be used if the ethanol content does not exceed 10% (E10). Gasohol containing methanol is not recommended by Yamaha because it can cause damage to the fuel system or vehicle performance problems.

Instrument and control functions

ECA11401

NOTICE

Use only unleaded gasoline. The use of leaded gasoline will cause severe damage to internal engine parts, such as the valves and piston rings, as well as to the exhaust system.

4

EAU86160

Fuel tank overflow hose

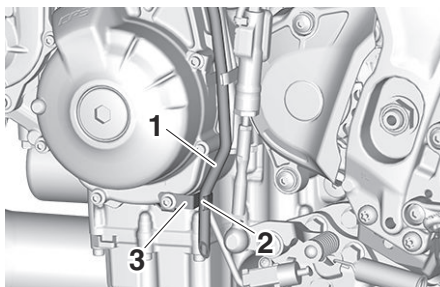

1. Fuel tank overflow hose
2. White mark
3. Clamp

The overflow hose drains excess gasoline and directs it safely away from the vehicle.

Before operating the vehicle:

- Check the fuel tank overflow hose connection.
- Check the fuel tank overflow hose for cracks or damage, and replace it if necessary.
- Make sure that the fuel tank overflow hose is not blocked, and clean it if necessary.
- Make sure that the fuel tank overflow hose is positioned as shown.

TIP

See page 7-11 for canister information.

Catalytic converter

EAU13435

The exhaust system contains catalytic converter(s) to reduce harmful exhaust emissions.

EWA10863



WARNING

The exhaust system is hot after operation. To prevent a fire hazard or burns:

- Do not park the vehicle near possible fire hazards such as grass or other materials that easily burn.
- Park the vehicle in a place where pedestrians or children are not likely to touch the hot exhaust system.
- Make sure that the exhaust system has cooled down before doing any maintenance work.
- Do not allow the engine to idle more than a few minutes. Long idling can cause a build-up of heat.

Seat

EAU57992

To remove the seat

1. Open the seat lock cover, insert the key into the seat lock, and then turn the key counterclockwise.

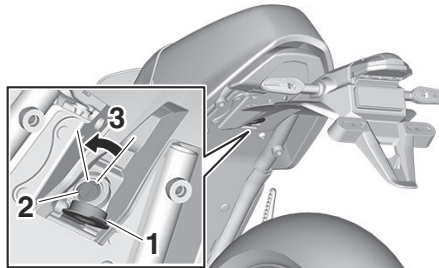

1. Seat lock cover
2. Seat lock
3. Unlock.

2. While holding the key in that position, slide the seat backward and then lift the rear of the seat up, and then pull the seat off.

To install the seat

1. Insert the projections into the seat holders as shown.

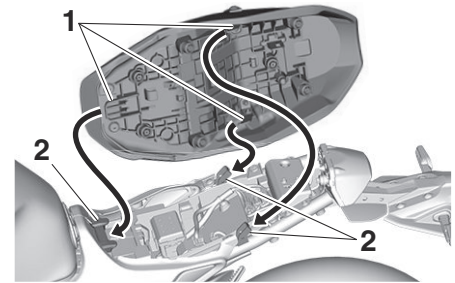

1. Projection
2. Seat holder

2. Push the rear of the seat down to lock it in place.
3. Remove the key.

TIP

Make sure that the seat is properly secured before riding.

Instrument and control functions

EAU91560

Rider footrest position

The rider footrests can be adjusted to one of two positions. From the factory, the footrests are in the low position. Have a Yamaha dealer adjust the positions of the rider footrests.

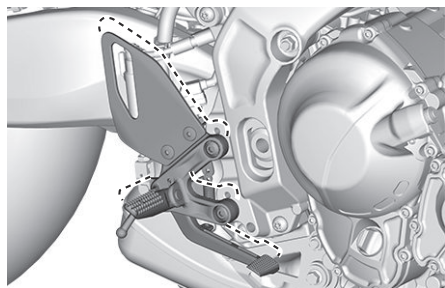
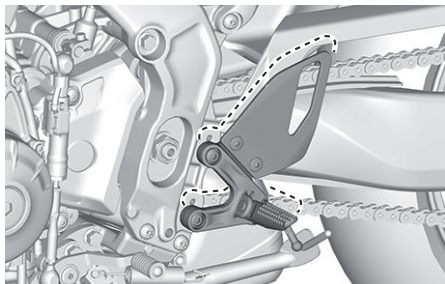

EAU46833

Handlebar position

The handlebar can be adjusted to one of two positions to suit the rider's preference. Have a Yamaha dealer adjust the position of the handlebar.

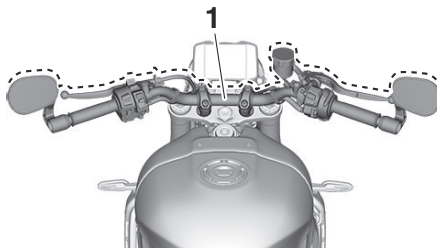

1. Handlebar

EAU76345

Adjusting the front fork

EWA14671

⚠ WARNING

Always adjust the spring preload on both fork legs equally, otherwise poor handling and loss of stability may result.

Each front fork leg is equipped with a spring preload adjusting bolt, the right front fork leg is equipped with a rebound damping force adjusting screw and the left front fork leg with a compression damping force adjusting screw.

ECA10102

NOTICE

To avoid damaging the mechanism, do not attempt to turn beyond the maximum or minimum settings.

Spring preload

Turn the adjusting bolt in direction (a) to increase the spring preload.

Turn the adjusting bolt in direction (b) to decrease the spring preload.

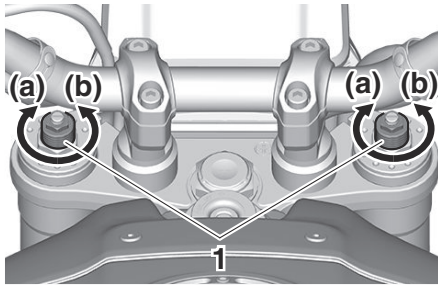

1. Spring preload adjusting bolt

The spring preload setting is determined by measuring distance A, shown in the illustration. The shorter distance A is, the higher the spring preload; the longer distance A is, the lower the spring preload.

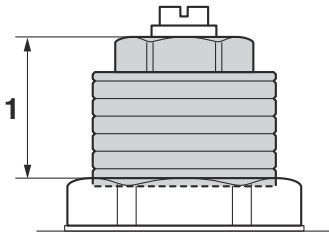

1. Distance A

Spring preload setting:

- Minimum (soft):
Distance A = 19.0 mm (0.75 in)
- Standard:
Distance A = 14.0 mm (0.55 in)
- Maximum (hard):
Distance A = 4.0 mm (0.16 in)

Rebound damping force

The rebound damping force is adjusted on the right fork leg only.

Turn the adjusting screw in direction (a) to increase the rebound damping force.

Turn the adjusting screw in direction (b) to decrease the rebound damping force.

To set the rebound damping force, turn the adjuster in direction (a) until it stops, and then count the clicks in direction (b).

TIP

Be sure to perform this adjustment on the right fork leg.

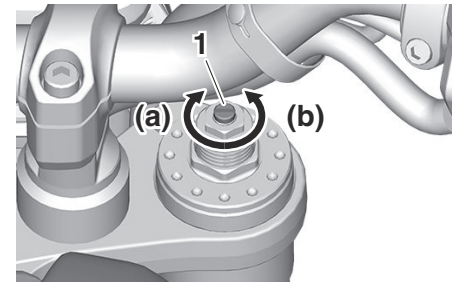

1. Rebound damping force adjusting screw

Rebound damping setting:

- Minimum (soft):
11 click(s) in direction (b)
- Standard:
6 click(s) in direction (b)
- Maximum (hard):
1 click(s) in direction (b)

TIP

- When turning the damping force adjuster in direction (a), the 0 click position and the 1 click position may be the same.
- When turning the damping force adjuster in direction (b), it may click beyond the stated specifications,

Instrument and control functions

however such adjustments are ineffective and may damage the suspension.

Compression damping force

The compression damping force is adjusted on the left fork leg only.

Turn the adjusting screw in direction (a) to increase the compression damping force.

Turn the adjusting screw in direction (b) to decrease the compression damping force.

To set the compression damping force, turn the adjuster in direction (a) until it stops, and then count the clicks in direction (b).

TIP

Be sure to perform this adjustment on the left fork leg.

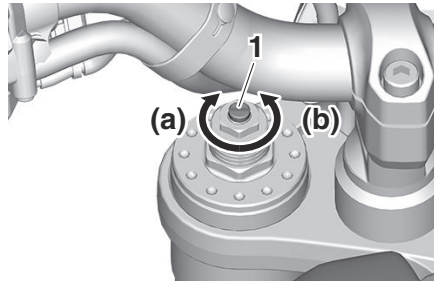

1. Compression damping force adjusting bolt (for fast compression damping)

Compression damping setting:

Minimum (soft):

11 click(s) in direction (b)

Standard:

6 click(s) in direction (b)

Maximum (hard):

1 click(s) in direction (b)

TIP

- When turning the damping force adjuster in direction (a), the 0 click position and the 1 click position may be the same.
- When turning the damping force adjuster in direction (b), it may click beyond the stated specifications, however such adjustments are in-

effective and may damage the suspension.

Adjusting the shock absorber assembly

EAU94912

This shock absorber assembly is equipped with a spring preload adjusting ring and a rebound damping force adjusting screw.

ECA10102

NOTICE

To avoid damaging the mechanism, do not attempt to turn beyond the maximum or minimum settings.

Spring preload

1. Remove the side covers. (See page 7-8.)
2. Turn the adjusting ring in direction (a) to increase the spring preload. Turn the adjusting ring in direction (b) to decrease the spring preload. Align the appropriate notch in the adjusting ring with the position indicator on the shock absorber.

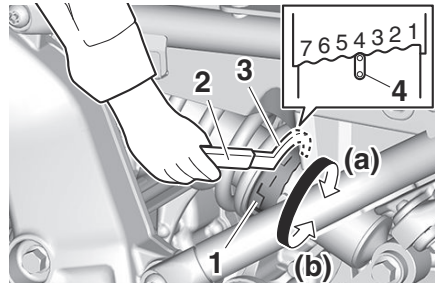

1. Spring preload adjusting ring
2. Extension bar
3. Special wrench
4. Position indicator

TIP

Use the special wrench and extension bar in the tool kit to make this adjustment.

Spring preload setting:

- Minimum (soft):
1
- Standard:
5
- Maximum (hard):
7

Rebound damping force

1. Remove the cap.

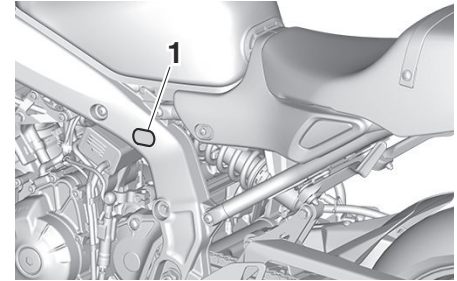

1. Cap

2. Turn the adjusting screw in direction (a) to increase the rebound damping force. Turn the adjusting screw in direction (b) to decrease the rebound damping force. To set the rebound damping force, turn the adjuster in direction (a) until it stops, and then count the turns in direction (b).

Instrument and control functions

EAU77390

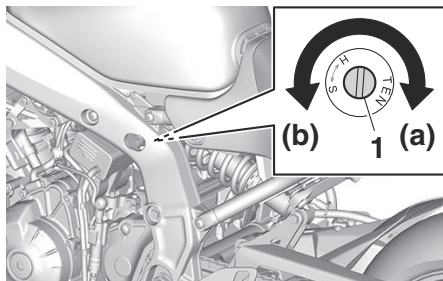

1. Rebound damping force adjusting screw

Rebound damping setting:

Minimum (soft):

2+1/2 turn(s) in direction (b)

Standard:

1 turn(s) in direction (b)

Maximum (hard):

0 turn(s) in direction (b)

TIP

When turning the damping force adjuster in direction (b), it may turn beyond the stated specifications, however such adjustments are ineffective and may damage the suspension.

EWA10222



WARNING

This shock absorber assembly contains highly pressurized nitrogen

gas. Read and understand the following information before handling the shock absorber assembly.

- Do not tamper with or attempt to open the cylinder assembly.
- Do not subject the shock absorber assembly to an open flame or other high heat source. This may cause the unit to explode due to excessive gas pressure.
- Do not deform or damage the cylinder in any way. Cylinder damage will result in poor damping performance.
- Do not dispose of a damaged or worn-out shock absorber assembly yourself. Take the shock absorber assembly to a Yamaha dealer for any service.

Auxiliary DC connectors

This vehicle is equipped with an auxiliary DC connector and a grip warmer DC connector. Consult your Yamaha dealer before installing any accessories.

Sidestand

EAU15306

The sidestand is located on the left side of the frame. Raise the sidestand or lower it with your foot while holding the vehicle upright.

TIP

The built-in sidestand switch is part of the ignition circuit cut-off system, which cuts the ignition in certain situations. (See the following section for an explanation of the ignition circuit cut-off system.)

EWA10242

WARNING

The vehicle must not be ridden with the sidestand down, or if the sidestand cannot be properly moved up (or does not stay up), otherwise the sidestand could contact the ground and distract the operator, resulting in a possible loss of control. Yamaha's ignition circuit cut-off system has been designed to assist the operator in fulfilling the responsibility of raising the sidestand before starting off. Therefore, check this system regularly and have a Yamaha

dealer repair it if it does not function properly.

EAU1270

Ignition circuit cut-off system

This system prevents in-gear engine starts unless the clutch lever is pulled and the sidestand is up. Also, it will stop the running engine should the sidestand be lowered while the transmission is in gear.

Periodically check this system via the following procedure.

TIP

- This check is most reliable if performed with a warmed-up engine.
- See pages 4-2 and 4-3 for switch operation information.

Instrument and control functions

EAU1280

4

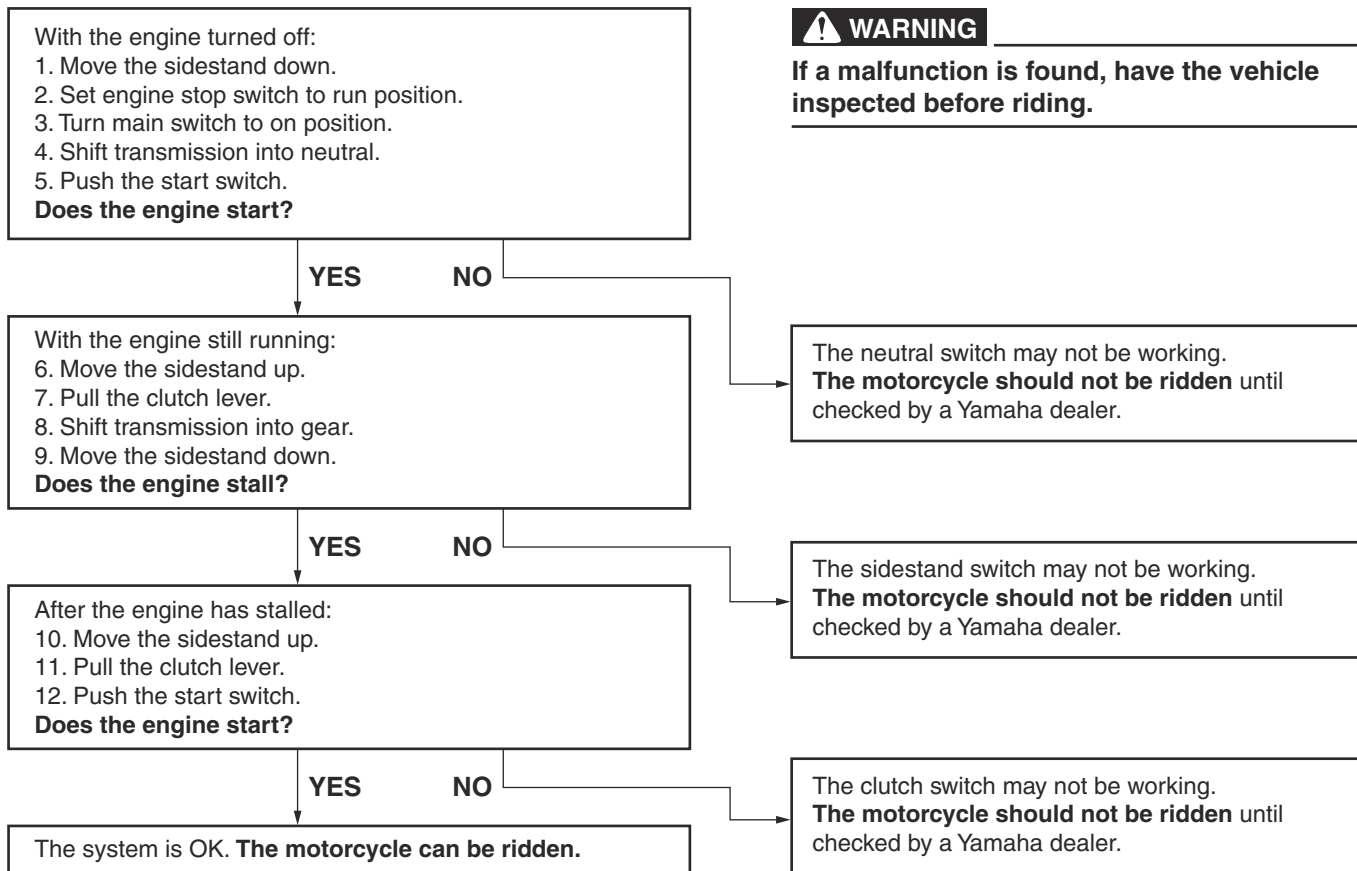

For your safety – pre-operation checks

EAU1559B

Inspect your vehicle each time you use it to make sure the vehicle is in safe operating condition. Always follow the inspection and maintenance procedures and schedules described in the Owner's Manual.

EWA11152



Failure to inspect or maintain the vehicle properly increases the possibility of an accident or equipment damage. Do not operate the vehicle if you find any problem. If a problem cannot be corrected by the procedures provided in this manual, have the vehicle inspected by a Yamaha dealer.

Before using this vehicle, check the following points:

ITEM	CHECKS	PAGE
Fuel	<ul style="list-style-type: none">• Check fuel level in fuel tank.• Refuel if necessary.• Check fuel line for leakage.• Check fuel tank overflow hose for obstructions, cracks or damage, and check hose connection.	4-23, 4-25
Engine oil	<ul style="list-style-type: none">• Check oil level in engine.• If necessary, add recommended oil to specified level.• Check vehicle for oil leakage.	7-12
Coolant	<ul style="list-style-type: none">• Check coolant level in reservoir.• If necessary, add recommended coolant to specified level.• Check cooling system for leakage.	7-13
Front brake	<ul style="list-style-type: none">• Check operation.• If soft or spongy, have Yamaha dealer bleed hydraulic system.• Check brake pads for wear.• Replace if necessary.• Check fluid level in reservoir.• If necessary, add specified brake fluid to specified level.• Check hydraulic system for leakage.	7-20, 7-20

For your safety – pre-operation checks

ITEM	CHECKS	PAGE
Rear brake	<ul style="list-style-type: none"> • Check operation. • If soft or spongy, have Yamaha dealer bleed hydraulic system. • Check brake pads for wear. • Replace if necessary. • Check fluid level in reservoir. • If necessary, add specified brake fluid to specified level. • Check hydraulic system for leakage. 	7-20, 7-20
Clutch	<ul style="list-style-type: none"> • Check operation. • Lubricate cable if necessary. • Check lever free play. • Adjust if necessary. 	7-18
Throttle grip	<ul style="list-style-type: none"> • Check for smooth rotation and automatic return. 	7-25
Control cables	<ul style="list-style-type: none"> • Make sure that operation is smooth. • Lubricate if necessary. 	7-25
Drive chain	<ul style="list-style-type: none"> • Check chain slack. • Adjust if necessary. • Check chain condition. • Lubricate if necessary. 	7-22, 7-24
Wheels and tires	<ul style="list-style-type: none"> • Check for damage. • Check tire condition and tread depth. • Check air pressure. • Correct if necessary. 	7-15, 7-18
Brake and shift pedals	<ul style="list-style-type: none"> • Make sure that operation is smooth. • Lubricate pedal pivoting points if necessary. 	7-25
Brake and clutch levers	<ul style="list-style-type: none"> • Make sure that operation is smooth. • Lubricate lever pivoting points if necessary. 	7-26
Sidestand	<ul style="list-style-type: none"> • Make sure that operation is smooth. • Lubricate pivot if necessary. 	7-27
Chassis fasteners	<ul style="list-style-type: none"> • Make sure that all nuts, bolts and screws are properly tightened. • Tighten if necessary. 	—

For your safety – pre-operation checks

ITEM	CHECKS	PAGE
Instruments, lights, signals and switches	<ul style="list-style-type: none">• Check operation.• Correct if necessary.	—
Sidestand switch	<ul style="list-style-type: none">• Check operation of ignition circuit cut-off system.• If system is not working correctly, have Yamaha dealer check vehicle.	4-32

Operation and important riding points

EAU15952

Read the Owner's Manual carefully to become familiar with all controls. If there is a control or function you do not understand, ask your Yamaha dealer.

EWA10272

WARNING

Failure to familiarize yourself with the controls can lead to loss of control, which could cause an accident or injury.

6

Engine break-in

There is never a more important period in the life of your engine than the period between 0 and 1600 km (1000 mi). For this reason, you should read the following material carefully.

Since the engine is brand new, do not put an excessive load on it for the first 1600 km (1000 mi). The various parts in the engine wear and polish themselves to the correct operating clearances. During this period, prolonged full-throttle operation or any condition that might result in engine overheating must be avoided.

EAU16842

1000–1600 km (600–1000 mi)

Avoid prolonged operation above 6300 r/min.

1600 km (1000 mi) and beyond

The vehicle can now be operated normally.

ECA10311

NOTICE

- Keep the engine speed out of the tachometer red zone.
 - If any engine trouble should occur during the engine break-in period, immediately have a Yamaha dealer check the vehicle.
-

EAU17094

0–1000 km (0–600 mi)

Avoid prolonged operation above 5300 r/min. **NOTICE:** After 1000 km (600 mi) of operation, the engine oil must be changed and the oil filter cartridge or element replaced.^[ECA10303]

EAU91411

ECA24110

Starting the engine

The ignition circuit cut-off system will enable starting when:

- the transmission is in the neutral position or
- the transmission is in gear, the sidestand is up, and the clutch lever is pulled.

To start the engine

1. Turn the main switch on and set the engine stop switch to the run position.
2. Confirm the indicator and warning light(s) come on for a few seconds, and then go off. (See page 4-5.)

TIP

- Do not start the engine if the malfunction indicator light remains on.
- The oil pressure and coolant temperature warning light should come on and stay on until the engine is started.
- The ABS warning light should come on and stay on until the vehicle reaches a speed of 5 km/h (3 mi/h).

NOTICE

If a warning or indicator light does not work as described above, have a Yamaha dealer check the vehicle.

3. Shift the transmission into the neutral position.
4. Start the engine by pushing the start switch.
5. Release the start switch when the engine starts, or after 5 seconds. Wait 10 seconds before pressing the switch again to allow battery voltage to restore.

TIP

If the engine fails to start, try again with the throttle grip turned by a 1/4 turn (20 degrees) open.

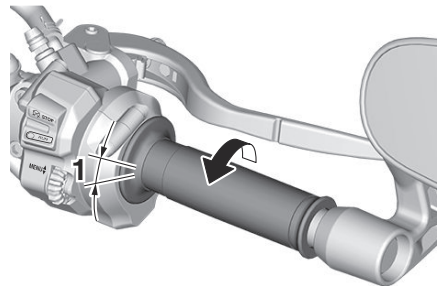

1. 1/4 turn (20 degrees)

ECA11043

NOTICE

For maximum engine life, never accelerate hard when the engine is cold!

Operation and important riding points

EAU68221

EAU91544

ECA22523

TIP

This model is equipped with:

- an inertial measurement unit (IMU). This unit stops the engine in case of a turnover. Turn the main switch off and then on before attempting to restart the engine. Failing to do so will prevent the engine from starting even though the engine will crank when pushing the start switch.
- an engine auto-stop system. The engine stops automatically if left idling for 20 minutes. If the engine stops, simply push the start switch to restart the engine.

Shifting

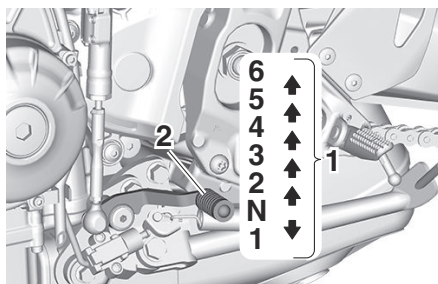

1. Gear positions
2. Shift pedal

Shifting gears lets you control the amount of engine power available for starting off, accelerating, climbing hills, etc. The gear positions are shown in the illustration.

TIP

- To shift the transmission into the neutral position (N), press the shift pedal down repeatedly until it reaches the end of its travel, and then slightly raise it.
- This model is equipped with a quick shifter. (See page 3-6.)

NOTICE

- When shifting, press the shift pedal firmly until you feel the gear shift is complete.
- Even with the transmission in the neutral position, do not coast for long periods of time with the engine off, nor tow the motorcycle for long distances. The transmission is properly lubricated only when the engine is running. Inadequate lubrication may damage the transmission.
- Except when using the quick shifter, always pull the clutch lever when changing gears to avoid damaging the engine, transmission, and drivetrain.

EAU85370

To start out and accelerate

1. Pull the clutch lever to disengage the clutch.
2. Shift the transmission into first gear. The neutral indicator light should go out.

Tips for reducing fuel consumption

Fuel consumption depends largely on your riding style. Consider the following tips to reduce fuel consumption:

- Shift up swiftly, and avoid high engine speeds during acceleration.
- Do not rev the engine while shifting down, and avoid high engine speeds with no load on the engine.
- Turn the engine off instead of letting it idle for an extended length of time (e.g., in traffic jams, at traffic lights or at railroad crossings).

3. Open the throttle gradually, and at the same time, release the clutch lever slowly.
4. After starting out, close the throttle, and at the same time, quickly pull the clutch lever in.
5. Shift the transmission into second gear. (Make sure not to shift the transmission into the neutral position.)
6. Open the throttle part way and gradually release the clutch lever.
7. Follow the same procedure when shifting to the next higher gear.

EAU85380

To decelerate

1. Release the throttle and apply both the front and the rear brakes smoothly to slow the motorcycle.
2. As the vehicle decelerates, shift to a lower gear.
3. When the engine is about to stall or runs roughly, pull the clutch lever in, use the brakes to slow the motorcycle, and continue to down-shift as necessary.
4. Once the motorcycle has stopped, the transmission can be shifted

into the neutral position. The neutral indicator light should come on and then the clutch lever can be released.

EWA17380

WARNING

- **Improper braking can cause loss of control or traction. Always use both brakes and apply them smoothly.**
- **Make sure that the motorcycle and the engine have sufficiently slowed before shifting to a lower gear. Engaging a lower gear when the vehicle or engine speed is too high could make the rear wheel lose traction or the engine to over-rev. This could cause loss of control, an accident and injury. It could also cause engine or drive train damage.**

Operation and important riding points

EAU17214

Parking

When parking, stop the engine, and then remove the key from the main switch.

EWA10312

WARNING

- Since the engine and exhaust system can become very hot, park in a place where pedestrians or children are not likely to touch them and be burned.
 - Do not park on a slope or on soft ground, otherwise the vehicle may overturn, increasing the risk of a fuel leak and fire.
 - Do not park near grass or other flammable materials which might catch fire.
-

EAU17246

Periodic inspection, adjustment, and lubrication will keep your vehicle in the safest and most efficient condition possible. Safety is an obligation of the vehicle owner/operator. The most important points of vehicle inspection, adjustment, and lubrication are explained on the following pages.

The intervals given in the periodic maintenance charts should be simply considered as a general guide under normal riding conditions. However, depending on the weather, terrain, geographical location, and individual use, the maintenance intervals may need to be shortened.

WARNING

EWA10322

Failure to properly maintain the vehicle or performing maintenance activities incorrectly may increase your risk of injury or death during service or while using the vehicle. If you are not familiar with vehicle service, have a Yamaha dealer perform service.

EWA15123

WARNING

Turn off the engine when performing maintenance unless otherwise specified.

- **A running engine has moving parts that can catch on body parts or clothing and electrical parts that can cause shocks or fires.**
- **Running the engine while servicing can lead to eye injury, burns, fire, or carbon monoxide poisoning – possibly leading to death. See page 1-2 for more information about carbon monoxide.**

EWA15461

WARNING

Brake discs, calipers, drums, and linings can become very hot during use. To avoid possible burns, let brake components cool before touching them.

EAU17303

Emission controls not only function to ensure cleaner air, but are also vital to proper engine operation and maximum performance. In the following periodic maintenance charts, the services related to emissions control are grouped separately. These services require specialized data, knowledge, and equipment. Maintenance, replacement, or repair of the emission control devices and systems may be performed by any repair establishment or individual that is certified (if applicable). Yamaha dealers are trained and equipped to perform these particular services.

Periodic maintenance and adjustment

EAU85230

Tool kit

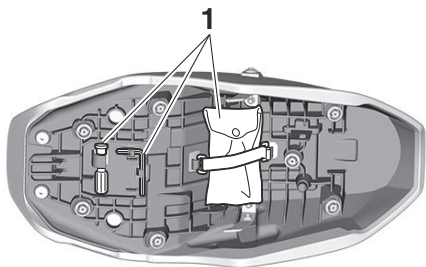

1. Tool kit

7

The tool kit is in the location shown.

The information included in this manual and the tools provided in the tool kit are intended to assist you in the performance of preventive maintenance and minor repairs. However, a torque wrench and other tools are necessary to perform certain maintenance work correctly.

TIP

If you do not have the tools or experience required for a particular job, have your Yamaha dealer perform it for you.

Periodic maintenance and adjustment

EAU71033

Periodic maintenance charts

TIP

- Items marked with an asterisk should be performed by your Yamaha dealer because these items require special tools, data, and technical skills.
- From 50000 km (30000 mi), repeat the maintenance intervals starting from 10000 km (6000 mi).
- **The annual checks must be performed every year, except if a distance-based maintenance is performed instead.**

EAU71052

Periodic maintenance chart for the emission control system

NO.	ITEM	CHECK OR MAINTENANCE JOB	ODOMETER READING					ANNUAL CHECK
			1000 km (600 mi)	10000 km (6000 mi)	20000 km (12000 mi)	30000 km (18000 mi)	40000 km (24000 mi)	
1	* Fuel line	<ul style="list-style-type: none"> • Check fuel hoses for cracks or damage. • Replace if necessary. 		√	√	√	√	√
2	* Spark plugs	<ul style="list-style-type: none"> • Check condition. • Adjust gap and clean. 		√		√		
		<ul style="list-style-type: none"> • Replace. 			√	√		
3	* Valve clearance	<ul style="list-style-type: none"> • Check and adjust. 	Every 40000 km (24000 mi)					
4	* Fuel injection	<ul style="list-style-type: none"> • Check engine idle speed. 	√	√	√	√	√	√
		<ul style="list-style-type: none"> • Check and adjust synchronization. 		√	√	√	√	√
5	* Exhaust system	<ul style="list-style-type: none"> • Check for leakage. • Tighten if necessary. • Replace gaskets if necessary. 	√	√	√	√	√	
6	* Evaporative emission control system	<ul style="list-style-type: none"> • Check control system for damage. • Replace if necessary. 			√		√	

Periodic maintenance and adjustment

EAU71354

General maintenance and lubrication chart

NO.	ITEM	CHECK OR MAINTENANCE JOB	ODOMETER READING					ANNUAL CHECK
			1000 km (600 mi)	10000 km (6000 mi)	20000 km (12000 mi)	30000 km (18000 mi)	40000 km (24000 mi)	
1	* Diagnostic system check	<ul style="list-style-type: none"> Perform dynamic inspection using Yamaha diagnostic tool. Check the error codes. 	√	√	√	√	√	√
2	* Air filter element	<ul style="list-style-type: none"> Replace. 	Every 40000 km (24000 mi)					
3	Clutch	<ul style="list-style-type: none"> Check operation. Adjust. 	√	√	√	√	√	
4	* Front brake	<ul style="list-style-type: none"> Check operation, fluid level, and for fluid leakage. Replace brake pads if necessary. 	√	√	√	√	√	√
5	* Rear brake	<ul style="list-style-type: none"> Check operation, fluid level, and for fluid leakage. Replace brake pads if necessary. 	√	√	√	√	√	√
6	* Brake hoses	<ul style="list-style-type: none"> Check for cracks or damage. 		√	√	√	√	√
		<ul style="list-style-type: none"> Replace. 	Every 4 years					
7	* Brake fluid	<ul style="list-style-type: none"> Change. 	Every 2 years					
8	* Wheels	<ul style="list-style-type: none"> Check runout and for damage. Replace if necessary. 		√	√	√	√	
9	* Tires	<ul style="list-style-type: none"> Check tread depth and for damage. Replace if necessary. Check air pressure. Correct if necessary. 		√	√	√	√	√
10	* Wheel bearings	<ul style="list-style-type: none"> Check bearing for looseness or damage. 		√	√	√	√	

Periodic maintenance and adjustment

NO.	ITEM	CHECK OR MAINTENANCE JOB	ODOMETER READING					ANNUAL CHECK
			1000 km (600 mi)	10000 km (6000 mi)	20000 km (12000 mi)	30000 km (18000 mi)	40000 km (24000 mi)	
11	* Swingarm pivot bearings	<ul style="list-style-type: none"> Check operation and for excessive play. 		√	√	√	√	
		<ul style="list-style-type: none"> Lubricate with lithium-soap-based grease. 	Every 50000 km (30000 mi)					
12	Drive chain	<ul style="list-style-type: none"> Check chain slack, alignment and condition. Adjust and lubricate chain with a special O-ring chain lubricant thoroughly. 	Every 1000 km (600 mi) and after washing the motorcycle, riding in the rain or riding in wet areas					
13	* Steering bearings	<ul style="list-style-type: none"> Check bearing assemblies for looseness. 	√	√		√		
		<ul style="list-style-type: none"> Moderately repack with lithium-soap-based grease. 			√		√	
14	* Chassis fasteners	<ul style="list-style-type: none"> Make sure that all nuts, bolts and screws are properly tightened. 		√	√	√	√	√
15	* Brake lever pivot shaft	<ul style="list-style-type: none"> Lubricate with silicone grease. 		√	√	√	√	√
16	Brake pedal pivot shaft	<ul style="list-style-type: none"> Lubricate with lithium-soap-based grease. 		√	√	√	√	√
17	Clutch lever pivot shaft	<ul style="list-style-type: none"> Lubricate with lithium-soap-based grease. 		√	√	√	√	√
18	Shift pedal pivot shaft	<ul style="list-style-type: none"> Lubricate with lithium-soap-based grease. 		√	√	√	√	√
19	Sidestand	<ul style="list-style-type: none"> Check operation. Lubricate with molybdenum disulfide grease. 		√	√	√	√	√
20	* Sidestand switch	<ul style="list-style-type: none"> Check operation and replace if necessary. 	√	√	√	√	√	√

Periodic maintenance and adjustment

NO.	ITEM	CHECK OR MAINTENANCE JOB	ODOMETER READING					ANNUAL CHECK
			1000 km (600 mi)	10000 km (6000 mi)	20000 km (12000 mi)	30000 km (18000 mi)	40000 km (24000 mi)	
21	* Front fork	<ul style="list-style-type: none"> • Check operation and for oil leakage. • Replace if necessary. 		√	√	√	√	
22	* Shock absorber assembly	<ul style="list-style-type: none"> • Check operation and for oil leakage. • Replace if necessary. 		√	√	√	√	
23	* Rear suspension relay arm and connecting arm pivoting points	<ul style="list-style-type: none"> • Check operation. 		√	√	√	√	
24	* Engine oil	<ul style="list-style-type: none"> • Change (warm engine before draining). • Check oil level and vehicle for oil leakage. 	√	√	√	√	√	√
25	* Engine oil filter cartridge	<ul style="list-style-type: none"> • Replace. 	√		√		√	
26	* Cooling system	<ul style="list-style-type: none"> • Check coolant level and vehicle for coolant leakage. 		√	√	√	√	√
		<ul style="list-style-type: none"> • Change. 	Every 3 years					
27	* Front and rear brake switches	<ul style="list-style-type: none"> • Check operation. 	√	√	√	√	√	√
28	* Moving parts and cables	<ul style="list-style-type: none"> • Lubricate. 		√	√	√	√	√
29	* Throttle grip	<ul style="list-style-type: none"> • Check operation. • Lubricate throttle grip housing tube guides. 		√	√	√	√	√
30	* Lights, signals and switches	<ul style="list-style-type: none"> • Check operation. • Adjust headlight beam. 	√	√	√	√	√	√

TIP

- Air filter
 - This model's air filter is equipped with a disposable oil-coated paper element, which must not be cleaned with compressed air to avoid damaging it.
 - The air filter element needs to be replaced more frequently when riding in unusually wet or dusty areas.
 - Hydraulic brake service
 - Regularly check and, if necessary, correct the brake fluid level.
 - Every two years replace the internal components of the brake master cylinders and calipers, and change the brake fluid.
 - Replace the brake hoses every four years and if cracked or damaged.
-

Periodic maintenance and adjustment

Side cover

The covers shown need to be removed to perform some of the maintenance jobs described in this chapter. Refer to this section each time a cover needs to be removed and installed.

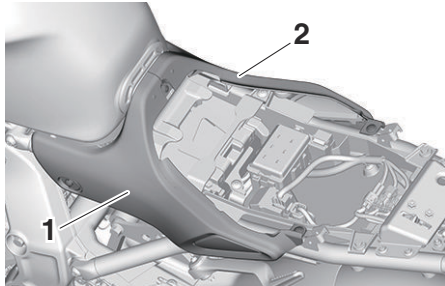

1. Cover A
2. Cover B

EAU94891

2. Remove the quick fastener A.

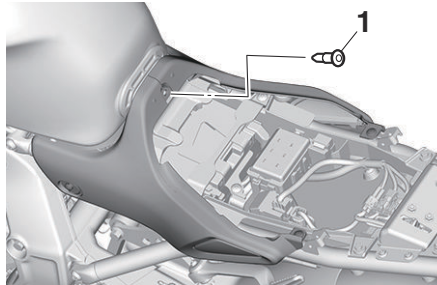

1. Quick fastener A

TIP

The quick fasteners A are removed by pushing in the center pin and then pulling the fastener out.

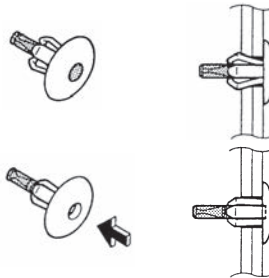

3. Remove the cover A.

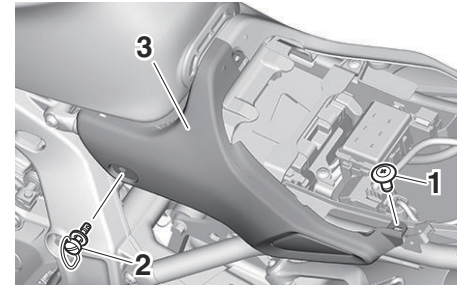

1. Quick fastener B
2. Quick fastener C
3. Cover A

TIP

To remove the quick fastener B, rotate its screwed portion counterclockwise with a phillips screwdriver.

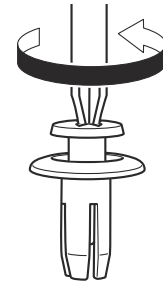

To remove the cover

1. Remove the seat. (See page 4-26.)

EAU94901

Periodic maintenance and adjustment

TIP
Remove the quick fastener C while turning the ring counterclockwise.

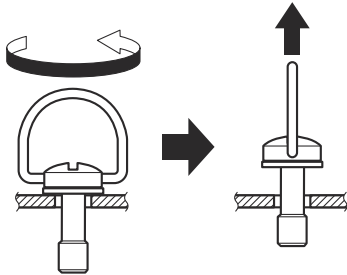

4. Remove the cover B.

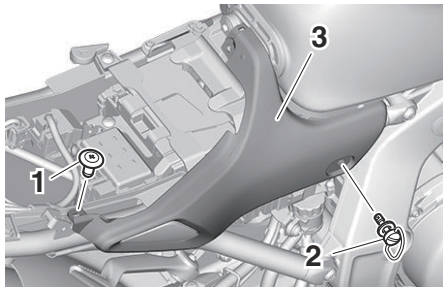

1. Quick fastener B
2. Quick fastener C
3. Cover B

To install the cover
1. Install the cover B.

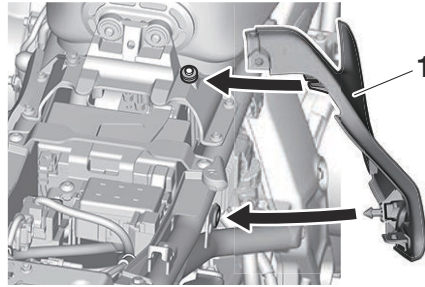

1. Cover B

2. Install the quick fastener C and quick fastener B.

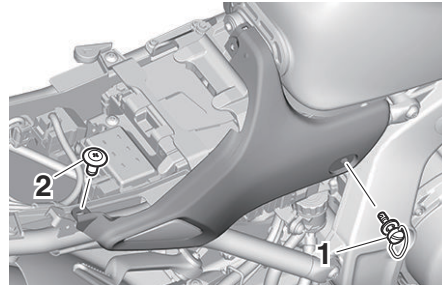

1. Quick fastener C
2. Quick fastener B

TIP
Turn the ring clockwise while pushing it, and then install the quick fastener C.

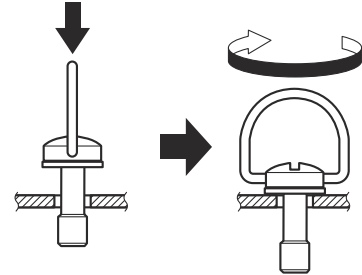

TIP
To install the quick fastener B, set it with its screwed portion pulled out from the surface of the quick fastener, and then push it down to the surface.

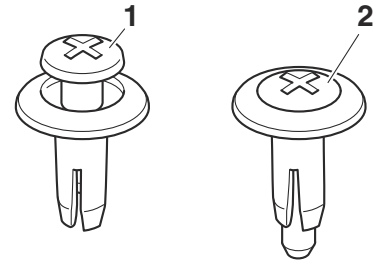

Periodic maintenance and adjustment

1. Quick fastener (before installation)
2. Quick fastener (after installation)
3. Install the cover A.

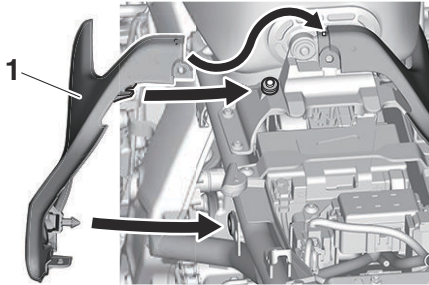

1. Cover A

4. Install the quick fastener C and quick fastener B.

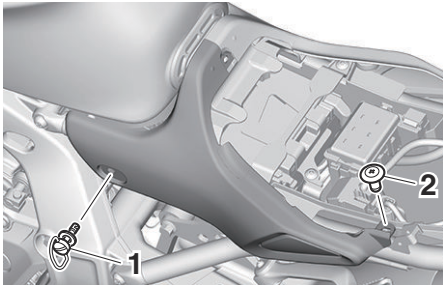

1. Quick fastener C
2. Quick fastener B

5. Install the quick fastener A.

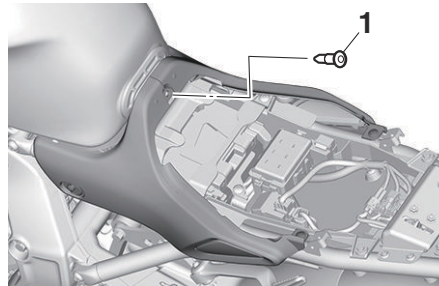

1. Quick fastener A

TIP

The quick fastener A is installed by pushing out the center pin, inserting the fastener into the panel, and then by pushing the center pin flush with the fastener head.

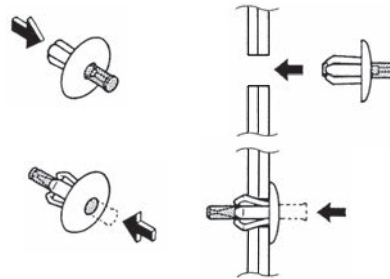

Checking the spark plugs

EAU19653

The spark plugs are important engine components, which should be checked periodically, preferably by a Yamaha dealer. Since heat and deposits will cause any spark plug to slowly erode, they should be removed and checked in accordance with the periodic maintenance and lubrication chart. In addition, the condition of the spark plugs can reveal the condition of the engine.

The porcelain insulator around the center electrode of each spark plug should be a medium-to-light tan (the ideal color when the vehicle is ridden normally), and all spark plugs installed in the engine should have the same color. If any spark plug shows a distinctly different color, the engine could be operating improperly. Do not attempt to diagnose such problems yourself. Instead, have a Yamaha dealer check the vehicle.

If a spark plug shows signs of electrode erosion and excessive carbon or other deposits, it should be replaced.

Specified spark plug:
NGK/LMAR9A-9

Before installing a spark plug, the spark plug gap should be measured with a wire thickness gauge and, if necessary, adjusted to specification.

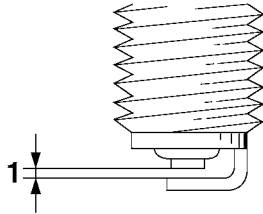

1. Spark plug gap

Spark plug gap:

0.8–0.9 mm (0.031–0.035 in)

Clean the surface of the spark plug gasket and its mating surface, and then wipe off any grime from the spark plug threads.

Tightening torque:

Spark plug:

13 N·m (1.3 kgf·m, 9.6 lb·ft)

TIP

If a torque wrench is not available when installing a spark plug, a good estimate of the correct torque is 1/4–1/2 turn past finger tight. However, the spark plug should be tightened to the specified torque as soon as possible.

ECA10841

NOTICE

Do not use any tools to remove or install the spark plug cap, otherwise the ignition coil coupler may get damaged. The spark plug cap may be difficult to remove because the rubber seal on the end of the cap fits tightly. To remove the spark plug cap, simply twist it back and forth while pulling it out; to install it, twist it back and forth while pushing it in.

Canister

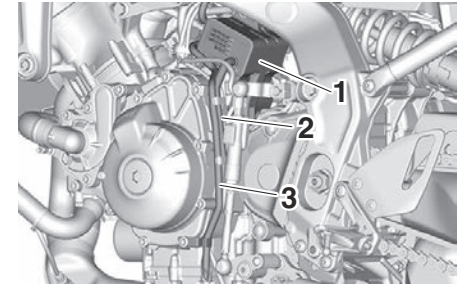

1. Canister
2. Canister breather
3. Fuel tank overflow hose

This model is equipped with a canister to prevent the discharging of fuel vapor into the atmosphere. Before operating this vehicle, make sure to check the following:

- Check each hose connection.
- Check each hose and canister for cracks or damage. Replace if damaged.
- Make sure that the canister breather is not blocked, and if necessary, clean it.

Periodic maintenance and adjustment

EAU94922

Engine oil

The engine oil level should be checked regularly. In addition, the oil must be changed and the oil filter cartridge replaced at the intervals specified in the periodic maintenance chart.

Recommended engine oil:

See page 9-1.

Oil quantity:

Oil change:

2.80 L (2.96 US qt, 2.46 Imp. qt)

With oil filter removal:

3.20 L (3.38 US qt, 2.82 Imp. qt)

ECA11621

NOTICE

- In order to prevent clutch slippage (since the engine oil also lubricates the clutch), do not mix any chemical additives. Do not use oils with a diesel specification of "CD" or oils of a higher quality than specified. In addition, do not use oils labeled "ENERGY CONSERVING II" or higher.
- Make sure that no foreign material enters the crankcase.

To check the engine oil level

1. Start the engine, warm it up for several minutes, and then turn it off.
2. Wait a few minutes until the oil level settles and with the vehicle on a level surface, hold it upright for an accurate reading.
3. Look at the check window located at the bottom-right side of the crankcase.

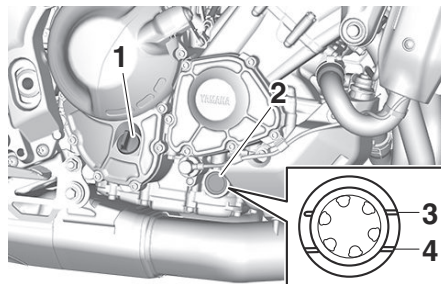

1. Engine oil filler cap
2. Engine oil level check window
3. Maximum level mark
4. Minimum level mark

TIP

The engine oil should be between the minimum and maximum level marks.

4. If the engine oil is at or below the minimum level mark, remove the oil filler cap and add oil.
5. Check the engine oil filler cap O-ring. Replace if damaged.

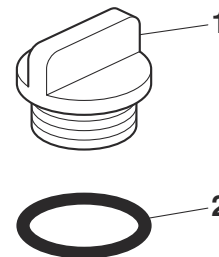

1. Engine oil filler cap
2. O-ring

6. Install the engine oil filler cap.

To change the engine oil and the oil filter cartridge

Have a Yamaha dealer change the engine oil and the oil filter cartridge.

Why Yamalube

EAU85450

YAMALUBE oil is a Genuine YAMAHA Part born of the engineers' passion and belief that engine oil is an important liquid engine component. We form teams of specialists in the fields of mechanical engineering, chemistry, electronics and track testing, and have them develop the engine together with the oil it will use. Yamalube oils take full advantage of the base oil's qualities and blend in the ideal balance of additives to make sure the final oil clears our performance standards. Thus, Yamalube mineral, semisynthetic and synthetic oils have their own distinct characters and value. Yamaha's experience gained over many years of research and development into oil since the 1960's helps make Yamalube the best choice for your Yamaha engine.

YAMALUBE®

Coolant

EAU51203

The coolant level should be checked regularly. In addition, the coolant must be changed at the intervals specified in the periodic maintenance chart.

Recommended coolant:

YAMALUBE coolant

Coolant quantity:

Coolant reservoir (max level mark):
0.28 L (0.30 US qt, 0.25 Imp.qt)

Radiator (including all routes):
1.72 L (1.82 US qt, 1.51 Imp.qt)

TIP

If genuine Yamaha coolant is not available, use an ethylene glycol antifreeze containing corrosion inhibitors for aluminum engines and mix with distilled water at a 1:1 ratio.

EAU20097

To check the coolant level

Since the coolant level varies with engine temperature, check when the engine is cold.

1. Park the vehicle on a level surface.

2. With the vehicle in an upright position, look at the coolant level in the reservoir.

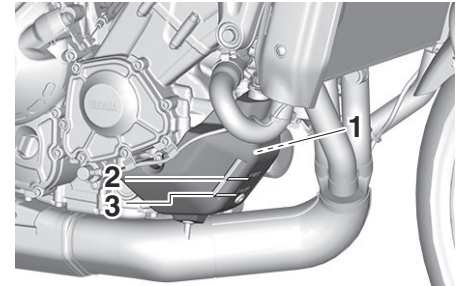

1. Coolant reservoir
2. Maximum level mark
3. Minimum level mark

3. If the coolant is at or below the minimum level mark, remove the coolant reservoir cap. **WARNING! Remove only the coolant reservoir cap. Never attempt to remove the radiator cap when the engine is hot.**^[EWA15162]

Periodic maintenance and adjustment

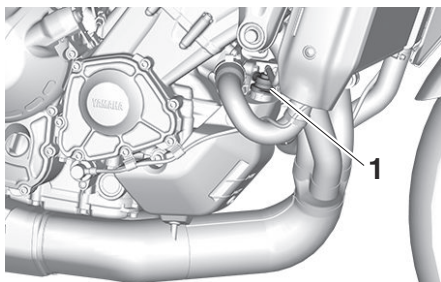

1. Coolant reservoir cap

4. Add coolant to the maximum level mark. **NOTICE: If coolant is not available, use distilled water or soft tap water instead. Do not use hard water or salt water since it is harmful to the engine. If water has been used instead of coolant, replace it with coolant as soon as possible, otherwise the cooling system will not be protected against frost and corrosion. If water has been added to the coolant, have a Yamaha dealer check the anti-freeze content of the coolant as soon as possible, otherwise the effectiveness of the coolant will be reduced.**^[ECA10473]

5. Install the coolant reservoir cap.

EAU33032

Changing the coolant

The coolant must be changed at the intervals specified in the periodic maintenance and lubrication chart. Have a Yamaha dealer change the coolant.

WARNING! Never attempt to remove the radiator cap when the engine is hot.^[EWA10382]

EAU36765

Air filter element

The air filter element must be replaced at the intervals specified in the periodic maintenance and lubrication chart. Have a Yamaha dealer replace the air filter element.

Checking the engine idling speed

EAU44735

Check the engine idling speed and, if necessary, have it corrected by a Yamaha dealer.

Engine idling speed:
1200–1400 r/min

Valve clearance

EAU21403

The valves are an important engine component, and since valve clearance changes with use, they must be checked and adjusted at the intervals specified in the periodic maintenance chart. Unadjusted valves can result in improper air-fuel mixture, engine noise, and eventually engine damage. To prevent this from occurring, have your Yamaha dealer check and adjust the valve clearance at regular intervals.

TIP

This service must be performed when the engine is cold.

Tires

EAU64412

Tires are the only contact between the vehicle and the road. Safety in all conditions of riding depends on a relatively small area of road contact. Therefore, it is essential to maintain the tires in good condition at all times and replace them at the appropriate time with the specified tires.

Tire air pressure

The tire air pressure should be checked and, if necessary, adjusted before each ride.

EWA10504

WARNING

Operation of this vehicle with improper tire pressure may cause severe injury or death from loss of control.

- **The tire air pressure must be checked and adjusted on cold tires (i.e., when the temperature of the tires equals the ambient temperature).**
- **The tire air pressure must be adjusted in accordance with the riding speed and with the total**

Periodic maintenance and adjustment

EWA10472

weight of rider, passenger, cargo, and accessories approved for this model.

Cold tire air pressure:

1 person:

Front:

250 kPa (2.50 kgf/cm², 36 psi)

Rear:

290 kPa (2.90 kgf/cm², 42 psi)

2 persons:

Front:

250 kPa (2.50 kgf/cm², 36 psi)

Rear:

290 kPa (2.90 kgf/cm², 42 psi)

Maximum load:

Vehicle:

221 kg (487 lb)

The vehicle's maximum load is the combined weight of the rider, passenger, cargo, and any accessories.

EWA10512

⚠ WARNING

Never overload your vehicle. Operation of an overloaded vehicle could cause an accident.

Tire inspection

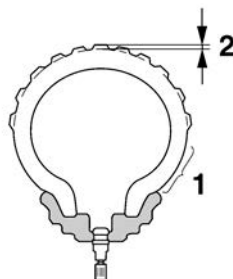

1. Tire sidewall
2. Tire tread depth

The tires must be checked before each ride. If the center tread depth reaches the specified limit, if the tire has a nail or glass fragments in it, or if the sidewall is cracked, have a Yamaha dealer replace the tire immediately.

Minimum tire tread depth (front and rear):

1.6 mm (0.06 in)

TIP

The tire tread depth limits may differ from country to country. Always comply with the local regulations.

⚠ WARNING

- Have a Yamaha dealer replace excessively worn tires. Besides being illegal, operating the vehicle with excessively worn tires decreases riding stability and can lead to loss of control.
- The replacement of all wheel and brake-related parts, including the tires, should be left to a Yamaha dealer, who has the necessary professional knowledge and experience to do so.
- Ride at moderate speeds after changing a tire since the tire surface must first be “broken in” for it to develop its optimal characteristics.

Tire information

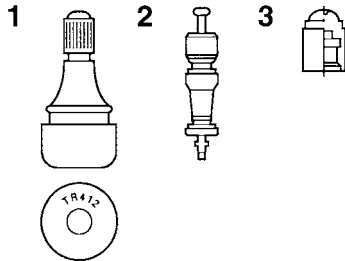

1. Tire air valve
2. Tire air valve core
3. Tire air valve cap with seal

This model is equipped with tubeless tires and tire air valves.

Tires age, even if they have not been used or have only been used occasionally. Cracking of the tread and sidewall rubber, sometimes accompanied by carcass deformation, is an evidence of ageing. Old and aged tires shall be checked by tire specialists to ascertain their suitability for further use.

EWA10902

WARNING

- The front and rear tires should be of the same make and de-

sign, otherwise the handling characteristics of the motorcycle may be different, which could lead to an accident.

- Always make sure that the valve caps are securely installed to prevent air pressure leakage.
- Use only the tire valves and valve cores listed below to avoid tire deflation during a ride.

After extensive tests, only the tires listed below have been approved for this model by Yamaha.

Front tire:

Size:

120/70ZR17M/C (58W)

Manufacturer/model:

BRIDGESTONE/BATTLAX HY-PERSPORT S22F

Rear tire:

Size:

180/55ZR17M/C (73W)

Manufacturer/model:

BRIDGESTONE/BATTLAX HY-PERSPORT S22R

FRONT and REAR:

Tire air valve:

TR412

Valve core:

#9100 (original)

WARNING

This motorcycle is fitted with super-high-speed tires. Note the following points in order to make the most efficient use of these tires.

- Use only the specified replacement tires. Other tires may run the danger of bursting at super high speeds.
- Brand-new tires can have a relatively poor grip on certain road surfaces until they have been “broken in”. Therefore, it is advisable before doing any high-speed riding to ride conservatively for approximately 100 km (60 mi) after installing a new tire.
- The tires must be warmed up before a high-speed run.
- Always adjust the tire air pressure according to the operating conditions.

Periodic maintenance and adjustment

EAU21963

Cast wheels

To maximize the performance, durability, and safe operation of your vehicle, note the following points regarding the specified wheels.

- The wheel rims should be checked for cracks, bends, warpage or other damage before each ride. If any damage is found, have a Yamaha dealer replace the wheel. Do not attempt even the smallest repair to the wheel. A deformed or cracked wheel must be replaced.
- The wheel should be balanced whenever either the tire or wheel has been changed or replaced. An unbalanced wheel can result in poor performance, adverse handling characteristics, and a shortened tire life.

EAU22083

Adjusting the clutch lever free play

Measure the clutch lever free play as shown.

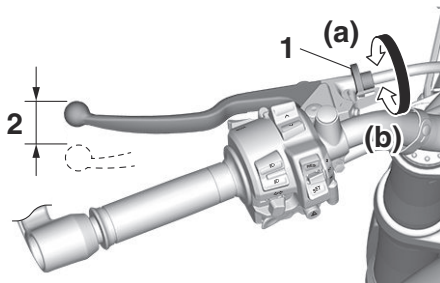

1. Clutch lever free play adjusting bolt
2. Clutch lever free play

Clutch lever free play:
10.0–15.0 mm (0.39–0.59 in)

Periodically check the clutch lever free play and, if necessary, adjust it as follows.

To increase the clutch lever free play, turn the clutch lever free play adjusting bolt in direction (a). To decrease the clutch lever free play, turn the adjusting bolt in direction (b).

TIP

If the specified free play cannot be obtained as described above or if the clutch does not operate correctly, have a Yamaha dealer check the internal clutch mechanism.

Checking the brake lever free play

EAU37914

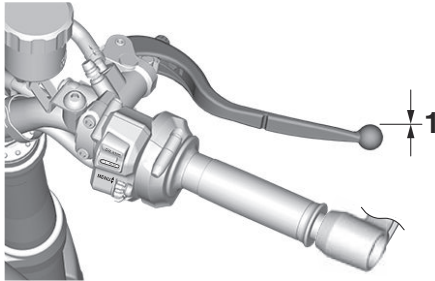

1. No brake lever free play

There should be no free play at the brake lever end. If there is free play, have a Yamaha dealer inspect the brake system.

EWA14212

WARNING

A soft or spongy feeling in the brake lever can indicate the presence of air in the hydraulic system. If there is air in the hydraulic system, have a Yamaha dealer bleed the system before operating the vehicle. Air in the hydraulic system will diminish the braking performance, which may re-

sult in loss of control and an accident.

Brake light switches

EAU36505

The brake light should come on just before braking takes effect. The brake light is activated by switches connected to the brake lever and brake pedal. Since the brake light switches are components of the anti-lock brake system, they should only be serviced by a Yamaha dealer.

Periodic maintenance and adjustment

Checking the front and rear brake pads

EAU22393

The front and rear brake pads must be checked for wear at the intervals specified in the periodic maintenance and lubrication chart.

Front brake pads

EAU36892

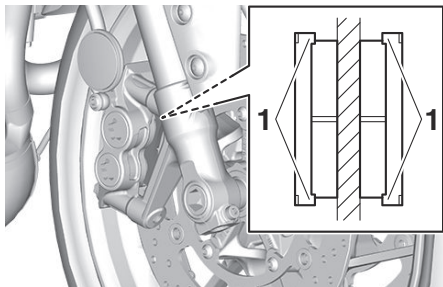

1. Brake pad wear indicator

Each front brake pad is provided with wear indicators, which allows you to check the brake pad wear without having to disassemble the brake. To check the brake pad wear, check the position of the wear indicators while applying the brake. If a brake pad has worn to the point that a wear indicator almost

touches the brake disc, have a Yamaha dealer replace the brake pads as a set.

Rear brake pads

EAU46292

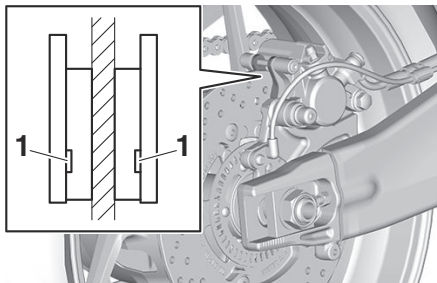

1. Brake pad wear indicator groove

Each rear brake pad is provided with wear indicator grooves, which allow you to check the brake pad wear without having to disassemble the brake. To check the brake pad wear, check the wear indicator grooves. If a brake pad has worn to the point that a wear indicator groove almost appears, have a Yamaha dealer replace the brake pads as a set.

Checking the brake fluid level

EAU40262

Before riding, check that the brake fluid is above the minimum level mark. Check the brake fluid level with the top of the reservoir level. Replenish the brake fluid if necessary.

Front brake

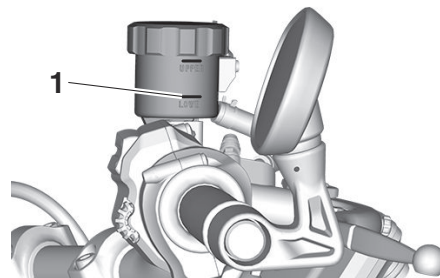

1. Minimum level mark

Periodic maintenance and adjustment

Rear brake

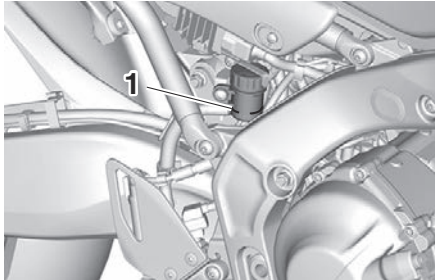

1. Minimum level mark

Specified brake fluid:
DOT 4

EWA16011

WARNING

Improper maintenance can result in loss of braking ability. Observe these precautions:

- Insufficient brake fluid may allow air to enter the brake system, reducing braking performance.
- Clean the filler cap before removing. Use only DOT 4 brake fluid from a sealed container.

- Use only the specified brake fluid; otherwise, the rubber seals may deteriorate, causing leakage.
- Refill with the same type of brake fluid. Adding a brake fluid other than DOT 4 may result in a harmful chemical reaction.
- Be careful that water or dust does not enter the brake fluid reservoir when refilling. Water will significantly lower the boiling point of the fluid and may result in vapor lock, and dirt may clog the ABS hydraulic unit valves.

fluid level goes down suddenly, have a Yamaha dealer check the cause before further riding.

NOTICE

Brake fluid may damage painted surfaces or plastic parts. Always clean up spilled fluid immediately.

As the brake pads wear, it is normal for the brake fluid level to gradually go down. A low brake fluid level may indicate worn brake pads and/or brake system leakage; therefore, be sure to check the brake pads for wear and the brake system for leakage. If the brake

ECA17641

Periodic maintenance and adjustment

Changing the brake fluid

EAU22734

Have a Yamaha dealer change the brake fluid every 2 years. In addition, have the seals of the master cylinders and brake calipers, as well as the brake hoses replaced at the intervals listed below or sooner if they are damaged or leaking.

- Brake seals: every 2 years
- Brake hoses: every 4 years

Drive chain slack

EAU22762

The drive chain slack should be checked before each ride and adjusted if necessary.

To check the drive chain slack

EAU97540

1. Place the motorcycle on the side-stand.

TIP

When checking and adjusting the drive chain slack, there should be no weight on the motorcycle.

2. Shift the transmission into the neutral position.
3. Find the center point of the chain (position B) by measuring (approx. 53 mm (2.09 in)) forward from the edge of the drive chain guard as shown.

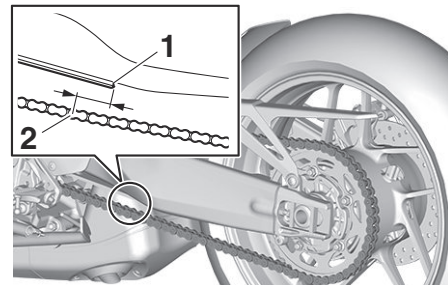

1. Edge of the drive chain guard
2. Position B

4. Push down on the center of the drive chain and measure the distance A from the drive chain guard to the middle of the chain link being pressed down at position B.

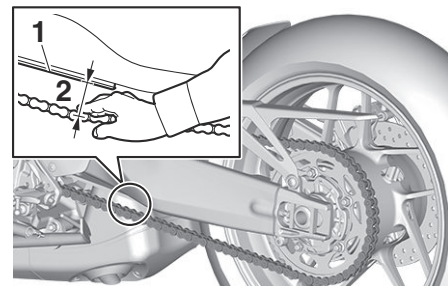

1. Drive chain guard
2. Distance A

Periodic maintenance and adjustment

Distance A:

45.0–50.0 mm (1.77–1.97 in)

5. If distance A is incorrect, adjust it as follows. **NOTICE: Improper drive chain slack will overload the engine as well as other vital parts of the motorcycle and can lead to chain slippage or breakage. If distance A is more than 55.0 mm (2.17 in), the chain can damage the frame, swingarm, and other parts. To prevent this from occurring, keep the drive chain slack within the specified limits.**^[ECA23070]

EAU74260

To adjust the drive chain slack

Consult a Yamaha dealer before adjusting the drive chain slack.

1. Loosen the axle nut and the locknut on each side of the swingarm.

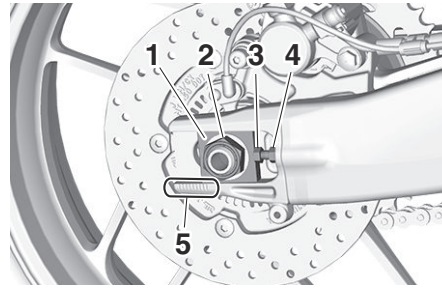

1. Drive chain puller
2. Axle nut
3. Drive chain slack adjusting bolt
4. Locknut
5. Alignment marks

2. To tighten the drive chain, turn the drive chain slack adjusting bolt on each side of the swingarm in direction (a). To loosen the drive chain, turn the adjusting bolt on each side of the swingarm in direction (b), and then push the rear wheel forward.

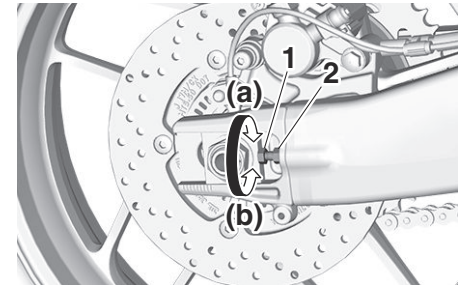

1. Drive chain slack adjusting bolt
2. Locknut

TIP

Using the alignment marks on each side of the swingarm, make sure that both drive chain pullers are in the same position for proper wheel alignment.

3. Tighten the axle nut, then the locknuts to their specified torques.

Tightening torques:

Axle nut:

105 N·m (10.5 kgf·m, 77 lb·ft)

Locknut:

16 N·m (1.6 kgf·m, 12 lb·ft)

4. Make sure that the drive chain pullers are in the same position, the

Periodic maintenance and adjustment

drive chain slack is correct, and the drive chain moves smoothly.

Cleaning and lubricating the drive chain

EAU23027

The drive chain must be cleaned and lubricated at the intervals specified in the periodic maintenance and lubrication chart, otherwise it will quickly wear out, especially when riding in dusty or wet areas. Service the drive chain as follows.

ECA10584

NOTICE

The drive chain must be lubricated after washing the motorcycle, riding in the rain or riding in wet areas.

1. Clean the drive chain with a drive chain cleaner and a small soft brush. **NOTICE: To prevent damaging the O-rings, do not clean the drive chain with steam cleaners, high-pressure washers or inappropriate solvents.**

[ECA11122]

2. Wipe the drive chain dry.
3. Thoroughly lubricate the drive chain with a special O-ring chain lubricant. **NOTICE: Do not use engine oil or any other lubricants**

for the drive chain, as they may contain substances that could damage the O-rings.[ECA11112]

Periodic maintenance and adjustment

Checking and lubricating the cables

EAU23098

The operation of all control cables and the condition of the cables should be checked before each ride, and the cables and cable ends should be lubricated if necessary. If a cable is damaged or does not move smoothly, have a Yamaha dealer check or replace it. **WARNING! Damage to the outer housing of cables may result in internal rusting and cause interference with cable movement. Replace damaged cables as soon as possible to prevent unsafe conditions.**^[EWA10712]

Recommended lubricant:

Yamaha cable lubricant or other suitable cable lubricant

Checking and lubricating the throttle grip

EAU82490

The operation of the throttle grip should be checked before each ride. In addition, the throttle grip housing should be lubricated by a Yamaha dealer at the intervals specified in the periodic maintenance chart.

Checking and lubricating the brake and shift pedals

EAU44276

The operation of the brake and shift pedals should be checked before each ride, and the pedal pivots should be lubricated if necessary.

Brake pedal

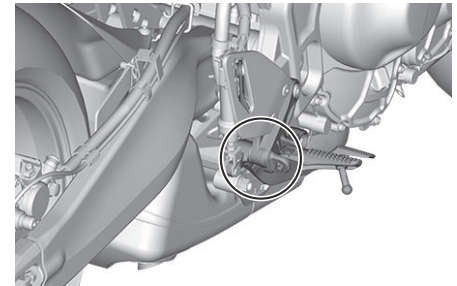

Periodic maintenance and adjustment

Shift pedal

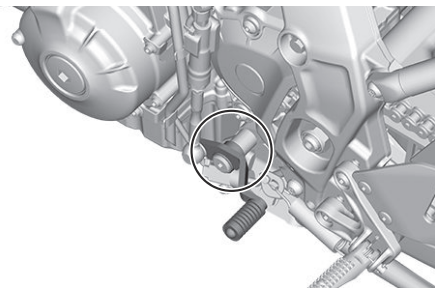

Recommended lubricant:
Lithium-soap-based grease

Checking and lubricating the brake and clutch levers

EAU94800

The operation of clutch lever should be checked before each ride, and the lever pivot should be lubricated if necessary. The brake lever pivot must be lubricated by a Yamaha dealer at the intervals specified in the periodic maintenance and lubrication chart.

Clutch lever

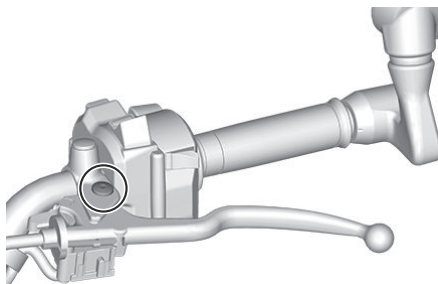

Brake lever

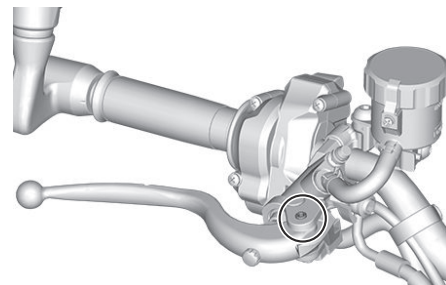

Recommended lubricants:
Clutch lever:
Lithium-soap-based grease
Brake lever:
Silicone grease

Checking and lubricating the sidestand

EAU89101

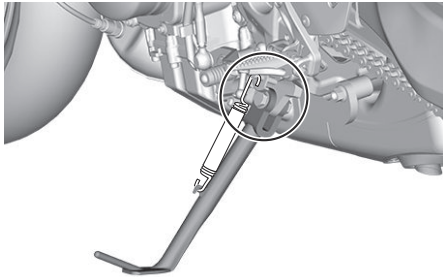

The operation of the sidestand should be checked before each ride, and the sidestand pivot and metal-to-metal contact surfaces should be lubricated if necessary.

EWA10732



WARNING

If the sidestand does not move up and down smoothly, have a Yamaha dealer check or repair it. Otherwise, the sidestand could contact the ground and distract the operator, resulting in a possible loss of control.

Recommended lubricant:
Molybdenum disulfide grease

Lubricating the swingarm pivots

EAUM1653

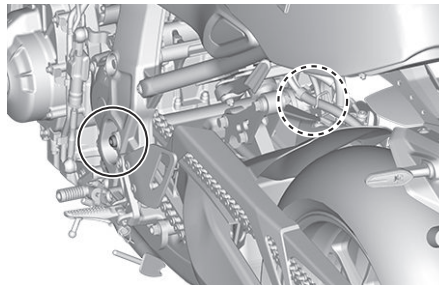

The swingarm pivots must be lubricated by a Yamaha dealer at the intervals specified in the periodic maintenance and lubrication chart.

Recommended lubricant:
Lithium-soap-based grease

Checking the front fork

EAU23273

The condition and operation of the front fork must be checked as follows at the intervals specified in the periodic maintenance and lubrication chart.

To check the condition

Check the inner tubes for scratches, damage and excessive oil leakage.

To check the operation

1. Place the vehicle on a level surface and hold it in an upright position.
WARNING! To avoid injury, securely support the vehicle so there is no danger of it falling over.^[EWA10752]
2. While applying the front brake, push down hard on the handlebars several times to check if the front fork compresses and rebounds smoothly.

Periodic maintenance and adjustment

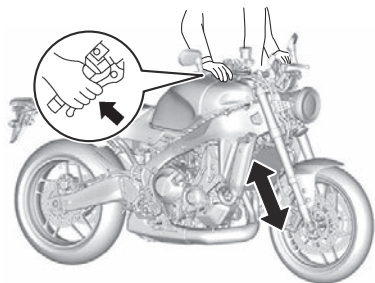

ECA10591

NOTICE

If any damage is found or the front fork does not operate smoothly, have a Yamaha dealer check or repair it.

Checking the steering

Worn or loose steering bearings may cause danger. Therefore, the operation of the steering must be checked as follows at the intervals specified in the periodic maintenance and lubrication chart.

1. Raise the front wheel off the ground. (See page 7-33.)
WARNING! To avoid injury, securely support the vehicle so there is no danger of it falling over.^[EWA10752]
2. Hold the lower ends of the front fork legs and try to move them forward and backward. If any free play can be felt, have a Yamaha dealer check or repair the steering.

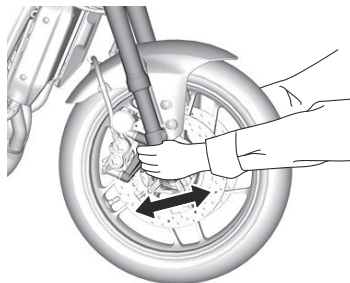

EAU23285

Checking the wheel bearings

EAU23292

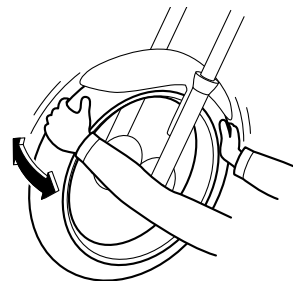

The front and rear wheel bearings must be checked at the intervals specified in the periodic maintenance and lubrication chart. If there is play in the wheel hub or if the wheel does not turn smoothly, have a Yamaha dealer check the wheel bearings.

Periodic maintenance and adjustment

Battery

EAU96251

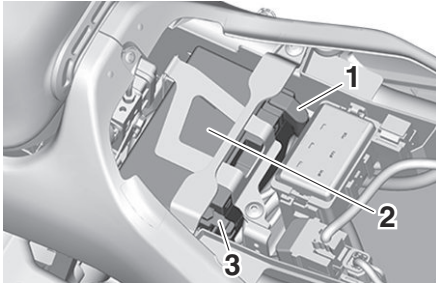

1. Positive battery lead (red)
2. Battery
3. Negative battery lead (black)

ECA22960

NOTICE

Use only the specified genuine YAMAHA battery. Using a different battery may cause the IMU to fail and the engine to stall.

The battery is located under the seat. (See page 4-26.)

ECA22970

NOTICE

The IMU is located under the battery. It is not user serviceable and very sensitive, so we advise against re-

moving the battery box or handling the IMU directly.

- Do not remove, modify, or place any foreign materials in or around the battery box.
- Do not subject the IMU to strong shocks and be careful when handling the battery.
- Do not obstruct the IMU breather hole and do not clean it with compressed air.

This model is equipped with a VRLA (Valve Regulated Lead Acid) battery. There is no need to check the electrolyte or to add distilled water. However, the battery lead connections need to be checked and, if necessary, tightened.

EWA10761

⚠ WARNING

- Electrolyte is poisonous and dangerous since it contains sulfuric acid, which causes severe burns. Avoid any contact with skin, eyes or clothing and always shield your eyes when working near batteries. In case

of contact, administer the following FIRST AID.

- **EXTERNAL:** Flush with plenty of water.
- **INTERNAL:** Drink large quantities of water or milk and immediately call a physician.
- **EYES:** Flush with water for 15 minutes and seek prompt medical attention.
- Batteries produce explosive hydrogen gas. Therefore, keep sparks, flames, cigarettes, etc., away from the battery and provide sufficient ventilation when charging it in an enclosed space.
- **KEEP THIS AND ALL BATTERIES OUT OF THE REACH OF CHILDREN.**

To remove the battery

1. Remove the side covers. (See page 7-8.)
2. Remove the bolts A and remove the battery stay.
3. Remove the bolt B and remove the battery holder.

Periodic maintenance and adjustment

ECA16522

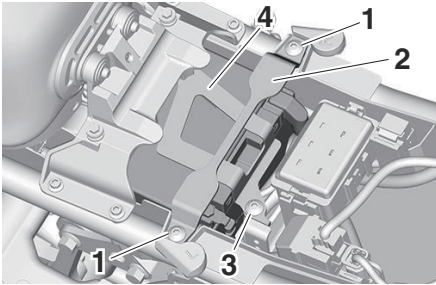

1. Bolt A
2. Battery stay
3. Bolt B
4. Battery holder

7

TIP

The battery holder is secured to the hook.

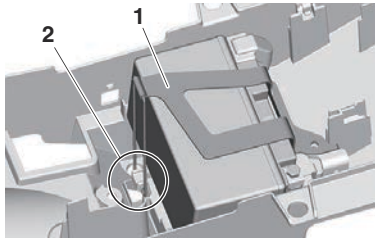

1. Battery holder
2. Hook

4. First, disconnect the negative battery lead, and then the positive battery lead.
5. Remove the battery.

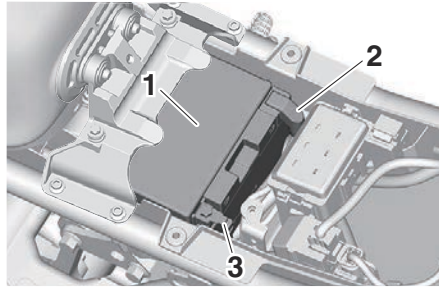

1. Battery
2. Positive battery lead (red)
3. Negative battery lead (black)

To install the battery

For installation, reverse the removal procedure.

To charge the battery

Have a Yamaha dealer charge the battery as soon as possible if it seems to have discharged. Keep in mind that the battery tends to discharge more quickly if the vehicle is equipped with optional electrical accessories.

NOTICE

To charge a VRLA (Valve Regulated Lead Acid) battery, a special (constant-voltage) battery charger is required. Using a conventional battery charger will damage the battery.

To store the battery

1. If the vehicle will not be used for more than one month, remove the battery, fully charge it, and then place it in a cool, dry place.
NOTICE: When removing the battery, be sure to turn the main switch off, then disconnect the negative lead before disconnecting the positive lead.^[ECA16304]
2. If the battery will be stored for more than two months, check it at least once a month and fully charge it if necessary.
3. Fully charge the battery before installation. **NOTICE:** When installing the battery, be sure to turn the main switch off, then connect the positive lead before

connecting the negative lead.

[ECA16842]

4. After installation, make sure that the battery leads are properly connected to the battery terminals.

NOTICE

Always keep the battery charged. Storing a discharged battery can cause permanent battery damage.

ECA16531

Replacing the fuses

EAU91572

The fuse box is located under the seat. (See page 4-26.)

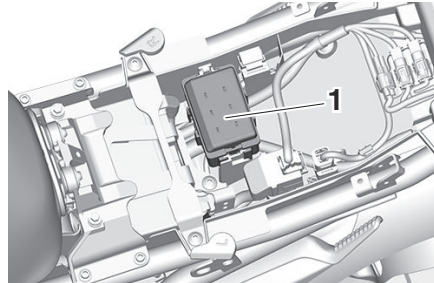

1. Fuse box

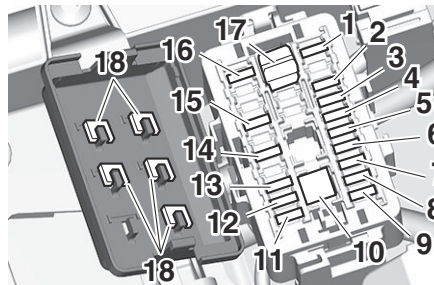

1. Brake light fuse
2. Ignition fuse 2
3. Signaling system fuse
4. Ignition fuse

5. Headlight fuse
6. ABS ECU fuse
7. Fuel injection system fuse
8. Electronic throttle valve fuse
9. Backup fuse 2
10. Main fuse
11. ABS motor fuse
12. ABS solenoid fuse
13. Radiator fan motor fuse
14. Terminal fuse 1
15. Backup fuse
16. Cruise control fuse
17. Fuse puller
18. Spare fuse

If a fuse is blown, replace it as follows.

TIP

- There is a spare fuse on the back side of the fuse box cover.
- Use a fuse puller to remove the fuse.

1. Turn the main switch off and turn off the electrical circuit in question.
2. Remove the fuse box cover by pressing inwards at the two points indicated on the cover and pulling upwards.

Periodic maintenance and adjustment

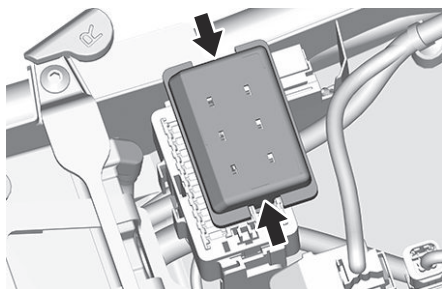

3. Remove the blown fuse using the fuse puller.

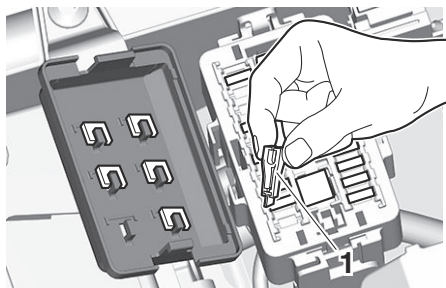

1. Fuse puller

4. Install a new fuse of the specified amperage. **WARNING! Do not use a fuse of a higher amperage rating than recommended to avoid causing extensive dam-**

age to the electrical system and possibly a fire.^[EWA15132]

Specified fuses:

- Main fuse: 50.0 A
- Terminal fuse 1: 2.0 A
- Headlight fuse: 7.5 A
- Brake light fuse: 2.0 A
- Signaling system fuse: 7.5 A
- Ignition fuse: 10.0 A
- Ignition fuse 2: 7.5 A
- Radiator fan motor fuse: 15.0 A
- ABS motor fuse: 30.0 A
- ABS ECU fuse: 7.5 A
- Fuel injection system fuse: 7.5 A
- ABS solenoid fuse: 15.0 A
- Cruise control fuse: 2.0 A
- Backup fuse: 7.5 A
- Backup fuse 2: 15.0 A

Electronic throttle valve fuse:
7.5 A

5. Insert the fuse puller, and then install the fuse box cover.
6. Turn the main switch on and turn on the electrical circuit in question to check if the device operates.
7. If the fuse immediately blows again, have a Yamaha dealer check the electrical system.

ECA27210

NOTICE

Do not drive while the fuse box cover is removed.

Vehicle lights

EAU80380

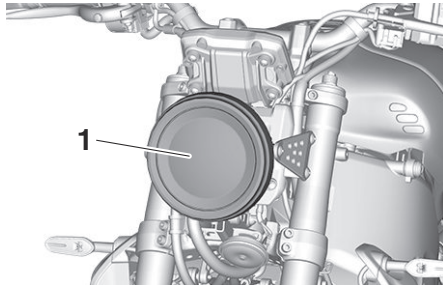

1. Headlight/Auxiliary light

Except for the license plate light bulb, this model's lights are all LED.

If an LED light does not come on, check the fuses and then have a Yamaha dealer check the vehicle. If the license plate light does not come on, check and replace the bulb. (See page 7-33.)

ECA16581

NOTICE

Do not affix any type of tinted film or stickers to the headlight lens.

License plate light

EAU24331

If the license plate light does not come on, have a Yamaha dealer check the electrical circuit or replace the bulb.

Supporting the motorcycle

EAU67131

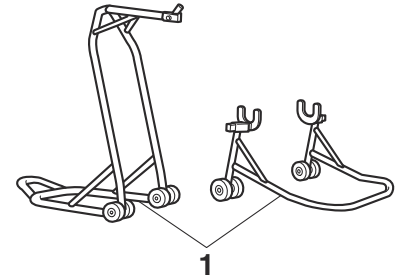

1. Maintenance stand (example)

Since this model is not equipped with a centerstand, use maintenance stands when removing the front or rear wheel or when performing other maintenance that requires the motorcycle to stand up right.

Check that the motorcycle is in a stable and level position before starting any maintenance.

Periodic maintenance and adjustment

Troubleshooting

EAU25872

Although Yamaha motorcycles receive a thorough inspection before shipment from the factory, trouble may occur during operation. Any problem in the fuel, compression, or ignition systems, for example, can cause poor starting and loss of power.

The following troubleshooting charts represent quick and easy procedures for checking these vital systems yourself. However, should your motorcycle require any repair, take it to a Yamaha dealer, whose skilled technicians have the necessary tools, experience, and know-how to service the motorcycle properly.

Use only genuine Yamaha replacement parts. Imitation parts may look like Yamaha parts, but they are often inferior, have a shorter service life and can lead to expensive repair bills.

EWA15142



When checking the fuel system, do not smoke, and make sure there are no open flames or sparks in the area, including pilot lights from water

heaters or furnaces. Gasoline or gasoline vapors can ignite or explode, causing severe injury or property damage.

Troubleshooting chart

1. Fuel

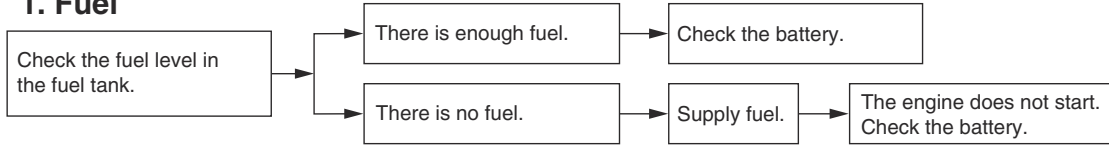

2. Battery

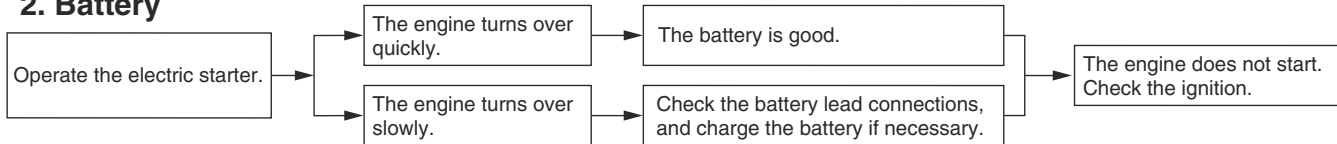

3. Ignition

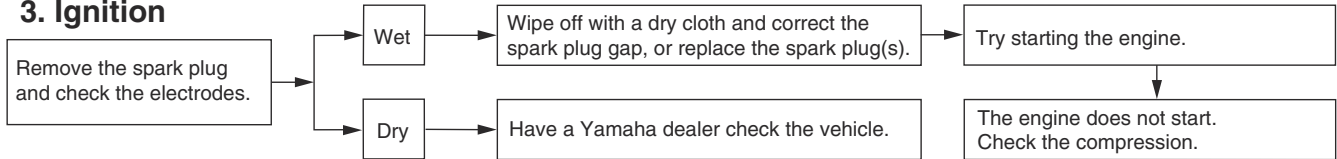

4. Compression

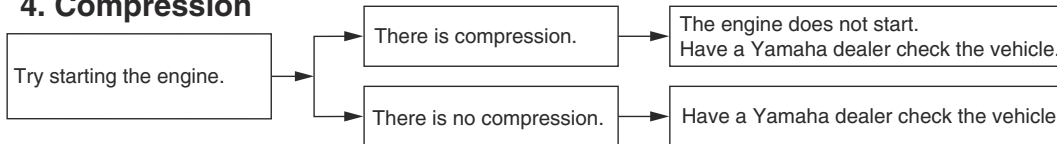

Periodic maintenance and adjustment

EAU86420

Engine overheating

EWAT1041

⚠ WARNING

- Do not remove the radiator cap when the engine and radiator are hot. Scalding hot fluid and steam may be blown out under pressure, which could cause serious injury. Be sure to wait until the engine has cooled.
- Place a thick rag, like a towel, over the radiator cap, and then slowly rotate the cap counterclockwise to the detent to allow any residual pressure to escape. When the hissing sound has stopped, press down on the cap while turning it counterclockwise, and then remove the cap.

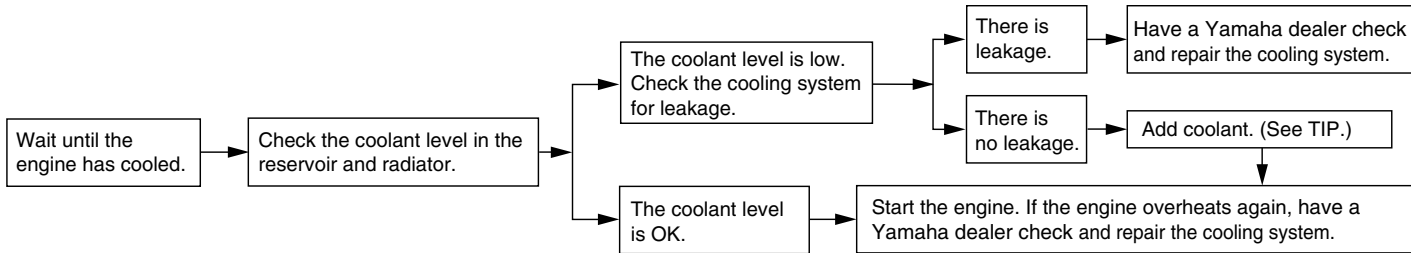

TIP

If coolant is not available, tap water can be temporarily used instead, provided that it is changed to the recommended coolant as soon as possible.

Matte color caution

EAU37834

EAU83446

NOTICE

Some models are equipped with matte colored finished parts. Be sure to consult a Yamaha dealer for advice on what products to use before cleaning the vehicle. Using a brush, harsh chemical products or cleaning compounds when cleaning these parts will scratch or damage their surface. Wax also should not be applied to any matte colored finished parts.

ECA15193

Care

Frequent, thorough cleaning of the vehicle will not only enhance its appearance but also will improve its general performance and extend the useful life of many components. Washing, cleaning, and polishing will also give you a chance to inspect the condition of the vehicle more frequently. Be sure to wash the vehicle after riding in the rain or near the sea, because salt is corrosive to metals.

Special care in winter

ECA26181

NOTICE

In cold weather, when roads may be salted as a de-icing method, it's important to clean the vehicle thoroughly to remove road salt and avoid corrosion. Wheel spokes, bolts/nuts and other unpainted metal parts can be especially vulnerable to corrosion from road salt. Apply an anti-corrosion product to any vulnerable parts after washing and drying the vehicle.

ECA26280

TIP

- The roads of heavy snowfall areas may be sprayed with salt as a de-icing method. This salt can stay on the roads well into spring, so be sure to wash the underside and chassis parts after riding in such areas.
- Genuine Yamaha care and maintenance products are sold under the YAMALUBE brand in many markets worldwide.
- See your Yamaha dealer for additional cleaning tips.

NOTICE

Improper cleaning can cause cosmetic and mechanical damage. Do not use:

- high-pressure washers or steam-jet cleaners. Excessive water pressure may cause water seepage and deterioration of wheel bearings, brakes, transmission seals and electrical devices. Avoid high-pressure detergent applications such as

Motorcycle care and storage

those available in coin-operated car washers.

- harsh chemicals, including strong acidic wheel cleaners, especially on spoke or magnesium wheels.
- harsh chemicals, abrasive cleaning compounds, or wax on matte-finished parts. Brushes can scratch and damage the matte-finish, use soft sponge or towel only.
- towels, sponges, or brushes contaminated with abrasive cleaning products or strong chemicals such as, solvents, gasoline, rust removers, brake fluid, or antifreeze, etc.

Before washing

1. Park the vehicle out of direct sunlight and allow it to cool. This will help avoid water spots.
2. Make sure all caps, covers, electrical couplers and connectors are tightly installed.
3. Cover the muffler end with a plastic bag and a strong rubber band.

4. Pre-soak stubborn stains like insects or bird droppings with a wet towel for a few minutes.
5. Remove road grime and oil stains with a quality degreasing agent and a plastic-bristle brush or sponge. **NOTICE: Do not use degreasing agent on areas requiring lubrication such as seals, gaskets, and wheel axles. Follow product instructions.**^[ECA26290]

Washing

1. Rinse off any degreaser and spray down the vehicle with a garden hose. Use only enough pressure to do the job. Avoid spraying water directly into the muffler, instrument panel, air inlet, or other inner areas such as underseat storage compartments.
2. Wash the vehicle with a quality automotive-type detergent mixed with cool water and a soft, clean towel or sponge. Use an old toothbrush or plastic-bristle brush for hard-to-reach places. **NOTICE: Use cold water if the vehicle has been exposed to salt. Warm wa-**

ter will increase salt's corrosive properties.^[ECA26301]

3. For windshield-equipped vehicles: Clean the windshield with a soft towel or sponge dampened with water and a pH neutral detergent. If necessary, use a high-quality windshield cleaner or polish for motorcycles. **NOTICE: Never use any strong chemicals to clean the windshield. Additionally, some cleaning compounds for plastic may scratch the windshield, so be sure to test all cleaning products before general application.**^[ECA26310]
4. Rinse off thoroughly with clean water. Be sure to remove all detergent residues, as they can be harmful to plastic parts.

After washing

1. Dry the vehicle with a chamois or absorbent towel, preferably microfiber terrycloth.
2. For drive chain-equipped models: Dry and then lubricate the drive chain to prevent rust.

3. Use a chrome polish to shine chrome, aluminum, and stainless steel parts. Often the thermally induced discoloring of stainless steel exhaust systems can be removed through polishing.
4. Apply a corrosion protection spray on all metal parts including chrome or nickel-plated surfaces.
WARNING! Do not apply silicone or oil spray to seats, hand grips, rubber foot pegs or tire treads. Otherwise these parts will become slippery, which could cause loss of control. Thoroughly clean the surfaces of these parts before operating the vehicle.^[EWA20651]
5. Treat rubber, vinyl, and unpainted plastic parts with a suitable care product.
6. Touch up minor paint damage caused by stones, etc.
7. Wax all painted surfaces using a non-abrasive wax or use a detail spray for motorcycles.
8. When finished cleaning, start the engine and let it idle for several mi-

nutes to help dry any remaining moisture.

9. If the headlight lens has fogged up, start the engine and turn on the headlight to help remove the moisture.
10. Let the vehicle dry completely before storing or covering it.

ECA26320

NOTICE

- Do not apply wax to rubber or unpainted plastic parts.
- Do not use abrasive polishing compounds as they will wear away the paint.
- Apply sprays and wax sparingly. Wipe off excess afterwards.

EWA20660

⚠ WARNING

Contaminants left on the brakes or tires can cause loss of control.

- Make sure there is no lubricant or wax on the brakes or tires.
- If necessary, wash the tires with warm water and a mild detergent.

- If necessary, clean the brake discs and pads with brake cleaner or acetone.
- Before riding at higher speeds, test the vehicle's braking performance and cornering behavior.

Motorcycle care and storage

Storage

Always store the vehicle in a cool, dry place. If necessary, protect it against dust with a porous cover. Be sure the engine and the exhaust system are cool before covering the vehicle. If the vehicle often sits for weeks at a time between uses, the use of a quality fuel stabilizer is recommended after each fill-up.

EAU83472

ECA21170

NOTICE

- **Storing the vehicle in a poorly ventilated room or covering it with a tarp, while it is still wet, will allow water and humidity to seep in and cause rust.**
- **To prevent corrosion, avoid damp cellars, stables (because of the presence of ammonia) and areas where strong chemicals are stored.**

Long term storage

Before storing the vehicle long term (60 days or more):

1. Make all necessary repairs and perform any outstanding maintenance.
2. Follow all instructions in the Care section of this chapter.
3. Fill up the fuel tank, adding fuel stabilizer according to product instructions. Run the engine for 5 minutes to distribute treated fuel through the fuel system.
4. For vehicles equipped with a fuel cock: Turn the fuel cock lever to the off position.
5. For vehicles with a carburetor: To prevent fuel deposits from building up, drain the fuel in the carburetor float chamber into a clean container. Retighten the drain bolt and pour the fuel back into the fuel tank.
6. Use a quality engine fogging oil according to product instructions to protect internal engine components from corrosion. If engine fogging oil is not available, perform the following steps for each cylinder:
 - a. Remove the spark plug cap and spark plug.
 - b. Pour a teaspoonful of engine oil into the spark plug bore.
 - c. Install the spark plug cap onto the spark plug, and then place the spark plug on the cylinder head so that the electrodes are grounded. (This will limit sparking during the next step.)
 - d. Turn the engine over several times with the starter. (This will coat the cylinder wall with oil.)
WARNING! To prevent damage or injury from sparking, make sure to ground the spark plug electrodes while turning the engine over.
7. Lubricate all control cables, pivots, levers and pedals, as well as the sidestand and centerstand (if equipped).
8. Check and correct the tire air pressure, and then lift the vehicle so that all wheels are off the ground. Otherwise, turn the wheels a little

[EWA10952]

once a month in order to prevent the tires from becoming degraded in one spot.

9. Cover the muffler outlet with a plastic bag to prevent moisture from entering it.
10. Remove the battery and fully charge it, or attach a maintenance charger to keep the battery optimally charged. **NOTICE: Confirm that the battery and its charger are compatible. Do not charge a VRLA battery with a conventional charger.**^[ECA26330]

TIP

- If the battery will be removed, charge it once a month and store it in a temperate location between 0-30 °C (32-90 °F).
 - See page 7-29 for more information on charging and storing the battery.
-

Specifications

Dimensions:

- Overall length:
2155 mm (84.8 in)
- Overall width:
860 mm (33.9 in)
- Overall height:
1155 mm (45.5 in)
- Seat height:
810 mm (31.9 in)
- Wheelbase:
1495 mm (58.9 in)
- Ground clearance:
140 mm (5.51 in)
- Minimum turning radius:
3.5 m (11.48 ft)

Weight:

- Curb weight:
193 kg (425 lb)

Engine:

- Combustion cycle:
4-stroke
- Cooling system:
Liquid cooled
- Valve train:
DOHC
- Cylinder arrangement:
Inline
- Number of cylinders:
3-cylinder
- Displacement:
890 cm³
- Bore × stroke:
78.0 × 62.1 mm (3.07 × 2.44 in)

- Starting system:
Electric starter

Engine oil:

- Recommended brand:



- SAE viscosity grades:
10W-40
- Recommended engine oil grade:
API service SG type or higher, JASO standard MA
- Engine oil quantity:
Oil change:
2.80 L (2.96 US qt, 2.46 Imp.qt)
- With oil filter removal:
3.20 L (3.38 US qt, 2.82 Imp.qt)

Coolant quantity:

- Coolant reservoir (up to the maximum level mark):
0.28 L (0.30 US qt, 0.25 Imp.qt)
- Radiator (including all routes):
1.72 L (1.82 US qt, 1.51 Imp.qt)

Fuel:

- Recommended fuel:
Unleaded gasoline (E10 acceptable)
- Octane number (RON):
95
- Fuel tank capacity:
14 L (3.7 US gal, 3.1 Imp.gal)
- Fuel reserve amount:
2.7 L (0.71 US gal, 0.59 Imp.gal)

Fuel injection:

- Throttle body:
ID mark:
B7N1

Drivetrain:

- Gear ratio:
1st:
2.571 (36/14)
- 2nd:
1.947 (37/19)
- 3rd:
1.619 (34/21)
- 4th:
1.381 (29/21)
- 5th:
1.190 (25/21)
- 6th:
1.037 (28/27)

Front tire:

- Type:
Tubeless
- Size:
120/70ZR17M/C (58W)
- Manufacturer/model:
BRIDGESTONE/BATTLAX HYPERSPORT S22F

Rear tire:

- Type:
Tubeless
- Size:
180/55ZR17M/C (73W)
- Manufacturer/model:
BRIDGESTONE/BATTLAX HYPERSPORT S22R

Loading:

Maximum load:

221 kg (487 lb)

(Total weight of rider, passenger, cargo and accessories)

Auxiliary light:

LED

License plate light:

5.0 W

Front brake:

Type:

Hydraulic dual disc brake

Rear brake:

Type:

Hydraulic single disc brake

Front suspension:

Type:

Telescopic fork

Rear suspension:

Type:

Swingarm (link suspension)

Electrical system:

System voltage:

12 V

Battery:

Model:

YTZ10S

Voltage, capacity:

12 V, 8.6 Ah (10 HR)

Bulb wattage:

Headlight:

LED

Brake/tail light:

LED

Front turn signal light:

LED

Rear turn signal light:

LED

Consumer information

EAU53562

Identification numbers

Record the vehicle identification number, engine serial number, and the model label information in the spaces provided below. These identification numbers are needed when registering the vehicle with the authorities in your area and when ordering spare parts from a Yamaha dealer.

VEHICLE IDENTIFICATION NUMBER:

ENGINE SERIAL NUMBER:

MODEL LABEL INFORMATION:

Vehicle identification number

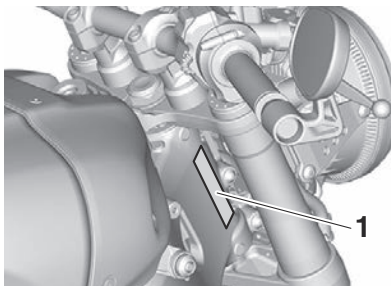

1. Vehicle identification number

The vehicle identification number is stamped into the steering head pipe. Record this number in the space provided.

TIP

The vehicle identification number is used to identify your motorcycle and may be used to register your motorcycle with the licensing authority in your area.

EAU26401

Engine serial number

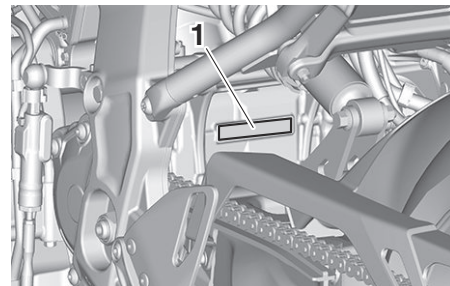

1. Engine serial number

The engine serial number is stamped into the crankcase.

EAU26442

Model label

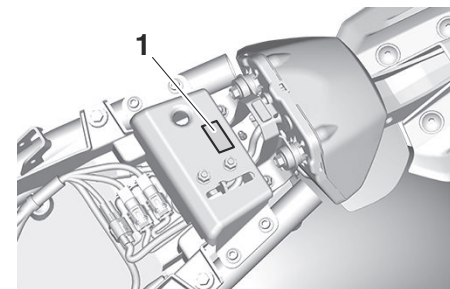

1. Model label

EAU26481

The model label is affixed to the frame under the seat. (See page 4-26.) Record the information on this label in the space provided. This information will be needed when ordering spare parts from a Yamaha dealer.

Diagnostic connector

EAU69910

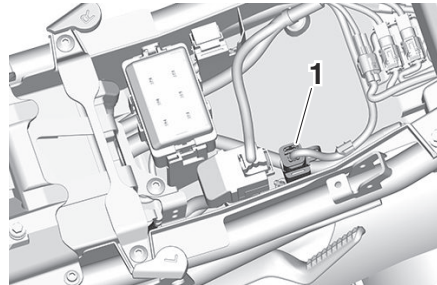

1. Diagnostic connector

The diagnostic connector is located as shown.

Consumer information

EAU0872

Use of your data

This is a brief summary of how Yamaha (Yamaha Motor Co. Ltd., and Yamaha Europe N.V.) uses your data. For more details, please go to the specific URL below for the Privacy Policy:

Country	Language	URL
Austria	German	https://www.yamaha-motor.eu/at/de/privacy/privacy-policy/
Belgium	Dutch	https://www.yamaha-motor.eu/be/nl/privacy/privacy-policy/
Belgium	French	https://www.yamaha-motor.eu/be/fr/privacy/privacy-policy/
Bulgaria	Bulgarian	https://www.yamaha-motor.eu/bg/bg/privacy/privacy-policy/
Czech Republic	Czech	https://www.yamaha-motor.eu/cz/cs/privacy/privacy-policy/
Denmark	Danish	https://www.yamaha-motor.eu/dk/da/privacy/privacy-policy/
Finland	Finnish	https://www.yamaha-motor.eu/fi/fi/privacy/privacy-policy/
France	French	https://www.yamaha-motor.eu/fr/fr/privacy/privacy-policy/
Germany	German	https://www.yamaha-motor.eu/de/de/privacy/privacy-policy/
Greece	Greek	https://www.yamaha-motor.eu/gr/el/privacy/privacy-policy/
Hungary	Hungarian	https://www.yamaha-motor.eu/hu/hu/privacy/privacy-policy/
Italy	Italian	https://www.yamaha-motor.eu/it/it/privacy/privacy-policy/
Ireland	English	https://www.yamaha-motor.eu/ie/en/privacy/privacy-policy/
Netherlands	Dutch	https://www.yamaha-motor.eu/nl/nl/privacy/Privacybeleid/
Norway	Norwegian	https://www.yamaha-motor.eu/no/nb/privacy/privacy-policy/
Poland	Polish	https://www.yamaha-motor.eu/pl/pl/privacy/polityka-prywatnosci/
Portugal	Portuguese	https://www.yamaha-motor.eu/pt/pt/privacy/privacy-policy/
Romania	Romanian	https://www.yamaha-motor.eu/ro/ro/privacy/privacy-policy/
Spain	Spanish	https://www.yamaha-motor.eu/es/es/privacy/privacy-policy/
Sweden	Swedish	https://www.yamaha-motor.eu/se/sv/privacy/privacy-policy/

Country	Language	URL
Switzerland	German	https://www.yamaha-motor.eu/ch/de/privacy/privacy-policy/
Switzerland	French	https://www.yamaha-motor.eu/ch/fr/privacy/privacy-policy/
Turkey	Turkish	https://www.yamaha-motor.eu/tr/tr/privacy/privacy-policy/
U.K.	English	https://www.yamaha-motor.eu/gb/en/privacy/privacy-policy/

What data we collect? and How we collect your data?

This vehicle collects three types of data through integrated Engine Control Units (ECU).: (1) Vehicle Identification Number (VIN); (2) live data showing the performance of the vehicle such as engine/motor operating state, vehicle speed, mileage; and (3) other data showing the status of the vehicle such as diagnostic trouble code (DTC).

The collected data will be uploaded to server at Yamaha Motor Co., Ltd. by attaching a special Yamaha diagnostic tool to the vehicle, only when maintenance checks or service procedures are performed.

How will we use your data?

Yamaha use collected data from your vehicle, (1) to conduct adequate maintenance service including diagnostics, (2) to implement proper warranty claim judgement, (3) to conduct research and development of vehicle, (4) to provide and improve quality of products, features, and services, (5) to ensure our business purpose, and (6) to comply with requirements of laws and regulations.

How we share your data?

We may share your data with: (i) our subsidiaries, affiliates, and business partners; (ii) dealers in your country or region, and (iii) contractors within the scope necessary to achieve the purpose of use described above.

How to contact us

Yamaha Motor Co., Ltd., and Yamaha Motor Europe N.V. are joint data controller regarding your data collected. Any questions or complaints regarding the processing of your Personal Data can be submitted in writing to:

Yamaha Motor Europe NV/Digital Marketing & CRM
– PO Box 75033 – 1117 ZN Schiphol – The Netherlands.

Consumer information

The **SOLE PURPOSE** of above provided contact information is **TO RESPOND DATA PROCESSING INQUIRY AND OTHER KINDS OF INQUIRIES WILL NOT BE RESPONDED**. Please provide the following information for the proper handling of your inquiry: **(1) Your Name; (2) Your Email Address; (3) Your Country of Residence; and (4) Your VIN**. We will use your personal information provided only for the purpose of supporting your data processing inquiry.

- A**
- ABS warning light..... 4-7
 - Air filter element..... 7-14
 - Auxiliary DC connectors.....4-31
 - Auxiliary system warning light..... 4-8
- B**
- Battery..... 7-29
 - BC.....3-6
 - Brake and clutch levers, checking and lubricating.....7-26
 - Brake and shift pedals, checking and lubricating..... 7-25
 - Brake control system (BC).....4-21
 - Brake fluid level, checking..... 7-20
 - Brake fluid, changing..... 7-22
 - Brake lever..... 4-20
 - Brake lever free play, checking..... 7-19
 - Brake light switches.....7-19
 - Brake pedal..... 4-21
- C**
- Cables, checking and lubricating..... 7-25
 - Canister.....7-11
 - Care..... 8-1
 - Catalytic converter..... 4-26
 - Clutch lever..... 4-19
 - Clutch lever free play, adjusting..... 7-18
 - Coolant..... 7-13
 - Cruise control indicator lights..... 4-6
 - Cruise control switches.....4-4
 - Cruise control system.....3-1
- D**
- D-MODE..... 3-3
 - Diagnostic connector..... 10-2
 - Dimmer/Pass switch.....4-3
- E**
- Display..... 4-9
 - Display, menu screen.....4-15
 - Drive chain slack.....7-22
 - Drive chain, cleaning and lubricating..... 7-24
- F**
- Engine break-in..... 6-1
 - Engine idling speed, checking.....7-15
 - Engine oil.....7-12
 - Engine overheating..... 7-36
 - Engine serial number..... 10-1
- G**
- Front and rear brake pads, checking.....7-20
 - Front fork, adjusting.....4-27
 - Front fork, checking.....7-27
 - Fuel.....4-23
 - Fuel consumption, tips for reducing..... 6-4
 - Fuel level warning light..... 4-6
 - Fuel tank cap.....4-23
 - Fuel tank overflow hose..... 4-25
 - Fuses, replacing..... 7-31
- H**
- Handlebar position, adjusting..... 4-27
 - Handlebar switches.....4-3
 - Hazard switch.....4-4
 - High beam indicator light..... 4-6
 - Horn switch.....4-4
- I**
- Identification numbers..... 10-1
 - Ignition circuit cut-off system..... 4-32
 - Immobilizer system.....4-1
 - Immobilizer system indicator light.....4-7
 - Indicator lights and warning lights..... 4-5
- L**
- License plate light..... 7-33
- M**
- Main switch/steering lock..... 4-2
 - Maintenance and lubrication, periodic.....7-4
 - Maintenance, emission control system.....7-3
 - Malfunction indicator light (MIL)..... 4-6
 - Matte color, caution..... 8-1
 - Model label..... 10-1
- N**
- Neutral indicator light..... 4-6
- O**
- Oil pressure and Coolant temperature warning light..... 4-8
- P**
- Parking.....6-5
 - Part locations..... 2-1
- Q**
- Quick shifter..... 3-6
- R**
- Rider footrest position, adjusting..... 4-27
- S**
- Safety information..... 1-1
 - Seat..... 4-26
 - Shift pedal..... 4-20
 - Shifting.....6-3
 - Shock absorber assembly, adjusting.....4-30
 - Side cover..... 7-8
 - Sidestand.....4-32
 - Sidestand, checking and lubricating.....7-27
 - Spark plugs, checking..... 7-10
 - Special features.....3-1
 - Specifications.....9-1
 - Stability control indicator light.....4-8
 - Starting the engine.....6-2
 - Steering, checking..... 7-28

Index

Stop/Run/Start switch.....	4-4
Storage.....	8-4
Supporting the motorcycle.....	7-33
Swingarm pivots, lubricating.....	7-27

T

TCS-MODE.....	3-4
Throttle grip, checking and lubricating.....	7-25
Tires.....	7-15
Tool kit.....	7-2
Troubleshooting.....	7-34
Troubleshooting chart.....	7-35
Turn signal indicator lights.....	4-6
Turn signal switch.....	4-3

U

Use, your data.....	10-3
---------------------	------

V

Valve clearance.....	7-15
Vehicle identification number.....	10-1
Vehicle lights.....	7-33

W

Wheel bearings, checking.....	7-28
Wheels.....	7-18

Y

Yamalube.....	7-13
---------------	------

