



2024

OWNER'S MANUAL
MANUEL DU PROPRIÉTAIRE
BEDIENUNGSANLEITUNG
USO E MANUTENZIONE
MANUAL DEL PROPIETARIO

YZ250F

⚠ Read this manual carefully before operating this vehicle.

⚠ Il convient de lire attentivement ce manuel avant la première utilisation du véhicule.





⚠ Bitte lesen Sie diese Bedienungsanleitung sorgfältig durch, bevor Sie das Fahrzeug in Betrieb nehmen.

⚠ Leggere attentamente questo manuale prima di utilizzare questo veicolo.

⚠ Lea este manual atentamente antes de utilizar este vehículo.

YZ250F
YZ250FR

BMF-28199-50

-  **Read this manual carefully before operating this vehicle. This manual should stay with this vehicle if it is sold.**
-  **Il convient de lire attentivement ce manuel avant la première utilisation du véhicule. Le manuel doit être remis avec le véhicule en cas de vente de ce dernier.**
-  **Bitte lesen Sie diese Bedienungsanleitung sorgfältig durch, bevor Sie das Fahrzeug in Betrieb nehmen. Diese Bedienungsanleitung muss, wenn das Fahrzeug verkauft wird, beim Fahrzeug verbleiben.**
-  **Leggere attentamente questo manuale prima di utilizzare questo veicolo. Questo manuale dovrebbe accompagnare il veicolo se viene venduto.**
-  **Lea este manual atentamente antes de utilizar este vehículo. Este manual debe acompañar al vehículo si este se vende.**



2024

OWNER'S MANUAL

YZ250F

⚠ Read this manual carefully before operating this vehicle.

YZ250F
YZ250FR

BMF-28199-50-E0

 **Read this manual carefully before operating this vehicle. This manual should stay with this vehicle if it is sold.**

CAN

This device complies with Industry Canada's licence-exempt RSSs. Operation is subject to the following two conditions:

(1) This device may not cause interference; and (2) This device must accept any interference, including interference that may cause undesired operation of the device.

The available scientific evidence does not show that any health problems are associated with using low power wireless devices. There is no proof, however, that these low power wireless devices are absolutely safe. Low power Wireless devices emit low levels of radio frequency energy (RF) in the microwave range while being used. Whereas high levels of RF can produce health effects (by heating tissue), exposure of low-level RF that does not produce heating effects causes no known adverse health effects. Many studies of low-level RF exposures have not found any biological effects.

Some studies have suggested that some biological effects might occur, but such findings have not been confirmed by additional research. COMMUN.CONT.UNIT ASSY. (T722-A00) has been tested and found to comply with IC radiation exposure limits set forth for an uncontrolled environment and meets RSS-102 of the IC radio frequency (RF) Exposure rules.

Reporting safety defects (For Canada)

If you believe that your vehicle has a defect which could cause a crash or could cause injury or death, you should immediately inform Transport Canada in addition to notifying Yamaha Motor Canada Ltd, Canada. If Transport Canada receives similar complaints, it may open an investigation, and if it finds that a safety defect exists in a group of vehicles, it may order a recall and remedy campaign. However, Transport Canada cannot become involved in individual problems between you, your dealer, or Yamaha Motor Canada Ltd., Canada.

To contact Transport Canada, you may call Defect Investigations and Recall Division at 819-420-4300 or toll free 1-800-333-0510, go to "tc.canada.ca" or email: mvs-sa@tc.gc.ca or write to Transport Canada, 330 Sparks Street Ottawa, ON, K1A 0N5.

You can also obtain other information about motor vehicle safety from "tc.canada.ca".

EUR

Declaration of Conformity:

Hereby, YAMAHA MOTOR CO., LTD declares that the radio equipment type, Communication Control Unit, T722-A00 is in compliance with Directive 2014/53/EU.

The full text of the EU declaration of conformity is available at the following internet address:

https://global.yamaha-motor.com/eu_doc/

Frequency band: 2.4GHz

The maximum radio frequency power: 50.12mW

Manufacturer:

YAMAHA MOTOR CO., LTD

2500 Shingai, Iwata, Shizuoka, 438-8501 Japan

Importer:

YAMAHA MOTOR EUROPE N.V.

Koolhovenlaan 101, 1119 NC Schiphol-Rijk, 1117 ZN, Schiphol, the Netherlands

For UK



Declaration of Conformity:

Hereby, YAMAHA MOTOR CO., LTD declares that the radio equipment type, Communication Control Unit, T722-A00 is in compliance with the Radio Equipment Regulations 2017.

The full text of the declaration of conformity is available at the following internet address:

https://global.yamaha-motor.com/eu_doc/

Frequency band: 2.4GHz

The maximum radio frequency power: 50.12mW

Manufacturer:

YAMAHA MOTOR CO., LTD

2500 Shingai, Iwata, Shizuoka, 438-8501 Japan

Importer:

YAMAHA MOTOR EUROPE N.V., BRANCH UK

Units A2-A3, Kingswey Business Park, Forsyth Road, Woking, Surrey. GU21 5SA. United Kingdom.

Information of the Lithium-ion battery (BR98)

Manufacturer:

Trend Power Technology (Changshu) INC.

No.868 Dongnan Avenue, Changshu High_tech Industrial
Development Zone, Jiangsu PRC,CN

Importer: (EU)

YAMAHA MOTOR EUROPE N.V.

Koolhovenlaan 101, 1119 NC Schiphol-Rijk, 1117 ZN, Schiphol, the Netherlands

Importer: (UK)

YAMAHA MOTOR EUROPE N.V., BRANCH UK

Units A2-A3, Kingswey Business Park, Forsyth Road, Woking, Surrey. GU21 5SA. United Kingdom.

EAM20080

**YZ250F
YZ250FR
OWNER'S MANUAL
©2024 by Yamaha Motor Co., Ltd.
First edition, June 2023
All rights reserved.
Any reprinting or unauthorized use
without the written permission of
Yamaha Motor Co., Ltd.
is expressly prohibited.
Printed in Japan.**

IMPORTANT

Congratulations on your purchase of a Yamaha YZ series. This model is the culmination of Yamaha's vast experience in the production of pacesetting racing machines. It represents the highest grade of craftsmanship and reliability that have made Yamaha a leader.

This manual explains operation, inspection, basic maintenance and tuning of your machine. If you have any questions about this manual or your machine, please contact your Yamaha dealer.

TIP

- Yamaha continually seeks advancements in product design and quality. Therefore, while this manual contains the most current product information available at the time of printing, there may be minor discrepancies between your machine and this manual. If you have any questions concerning this manual, please consult your Yamaha dealer.
- This manual is intended for those who have basic knowledge and skill concerning the servicing of Yamaha motorcycles (e.g., Yamaha dealers, service engineers, etc.). Those who have little knowledge and skill concerning servicing are requested not to undertake inspection, adjustment, disassembly, or reassembly only by reference to this manual. It may lead to servicing trouble and mechanical damage.



WARNING

PLEASE READ THIS MANUAL CAREFULLY AND COMPLETELY BEFORE OPERATING THIS MACHINE. DO NOT ATTEMPT TO OPERATE THIS MACHINE UNTIL YOU HAVE ATTAINED A SATISFACTORY KNOWLEDGE OF ITS CONTROLS AND OPERATING FEATURES AND UNTIL YOU HAVE BEEN TRAINED IN SAFE AND PROPER RIDING TECHNIQUES. REGULAR INSPECTIONS AND CAREFUL MAINTENANCE, ALONG WITH GOOD RIDING SKILLS, WILL ENSURE THAT YOU SAFELY ENJOY THE CAPABILITIES AND THE RELIABILITY OF THIS MACHINE.

IMPORTANT MANUAL INFORMATION

Particularly important information is distinguished in this manual by the following notations.

	<p>This is the safety alert symbol. It is used to alert you to potential personal injury hazards. Obey all safety messages that follow this symbol to avoid possible injury or death.</p>
WARNING	<p>A WARNING indicates a hazardous situation which, if not avoided, could result in death or serious injury.</p>
NOTICE	<p>A NOTICE indicates special precautions that must be taken to avoid damage to the vehicle or other property.</p>
TIP	<p>A TIP provides key information to make procedures easier or clearer.</p>

TABLE OF CONTENTS

GENERAL INFORMATION	1
SPECIFICATIONS	2
PERIODIC CHECKS AND ADJUSTMENTS	3
CHASSIS	4
ENGINE	5
FUEL SYSTEM	6
ELECTRICAL SYSTEM	7
TROUBLESHOOTING	8
TUNING	9

GENERAL INFORMATION

SAFETY INFORMATION	1-1
FOR SAFETY, BE SURE TO OBEY THE FOLLOWING:	1-1
ABOUT THE BATTERY	1-4
LITHIUM-ION BATTERY	1-4
LITHIUM-ION BATTERY DEGRADATION	1-4
RECYCLING THE BATTERY	1-4
LOCATION OF IMPORTANT LABELS	1-5
DESCRIPTION	1-8
IDENTIFICATION	1-9
VEHICLE IDENTIFICATION NUMBER	1-9
ENGINE SERIAL NUMBER.....	1-9
INCLUDED PARTS	1-10
SIDESTAND.....	1-10
NIPPLE WRENCH	1-10
HANDLEBAR PROTECTOR	1-10
FUEL HOSE JOINT COVER	1-10
POWER TUNER.....	1-10
IMPORTANT INFORMATION	1-13
PREPARATION FOR REMOVAL AND DISASSEMBLY	1-13
REPLACEMENT PARTS.....	1-13
INSTRUMENT AND CONTROL FUNCTIONS	1-14
ENGINE STOP SWITCH	1-14
START SWITCH	1-14
LAUNCH CONTROL SYSTEM	1-14
LAP TIME RECORD MODE	1-15
DRIVE MODE.....	1-15
SHIFT PEDAL	1-16
FRONT BRAKE LEVER.....	1-16
REAR BRAKE PEDAL.....	1-16
STARTER KNOB	1-16
FUEL TANK CAP	1-16
STARTING AND BREAK-IN	1-18
FUEL.....	1-18
STARTING A COLD ENGINE.....	1-18
STARTING A WARM ENGINE	1-19
BREAK-IN PROCEDURES	1-19
ENGINE STARTING PRECAUTION	1-19

MAINTENANCE AFTER BREAK-IN	1-20
MAJOR MAINTENANCE	1-20
AIR FILTER MAINTENANCE.....	1-20
TORQUE-CHECK POINTS	1-21
MOTORCYCLE CARE AND STORAGE	1-23
CARE	1-23
STORAGE.....	1-24

EAM20168

SAFETY INFORMATION

Be sure to read this manual carefully and completely in order to operate the machine safely and correctly prior to riding the Yamaha machine, and take care to maintain it properly and operate it safely.

EAM30401

FOR SAFETY, BE SURE TO OBEY THE FOLLOWING:

Be a Responsible Owner

As the vehicle's owner, you are responsible for the safe and proper operation of your motorcycle.

Motorcycles are single-track vehicles.

Their safe use and operation are dependent upon the use of proper riding techniques as well as the expertise of the operator. Every operator should know the following requirements before riding this motorcycle.

He or she should:

1. Obtain thorough instructions from a competent source on all aspects of motorcycle operation.
2. Observe the warnings and maintenance requirements in this manual.
3. Obtain qualified training in safe and proper riding techniques.
4. Obtain professional technical service as indicated in this manual and/or when made necessary by mechanical conditions.
5. Never operate a motorcycle without proper training or instruction. Take a training course. Beginners should receive training from a certified instructor. Contact an authorized motorcycle dealer to find out about the training courses nearest you.

Safe Riding

Perform the pre-operation checks each time you use the vehicle to make sure it is in safe operating condition. Failure to inspect or maintain the vehicle properly increases the possibility of an accident or equipment damage. Refer to "PRE-OPERATION INSPECTION AND MAINTENANCE" on page 3-6 for a list of pre-operation checks.

1. This motorcycle is designed for off-road use only, therefore, it is illegal to operate it on public streets, roads, or highways, even a dirt or gravel one. Off-road use on public lands may be illegal. Please check local regulations before riding.
2. This motorcycle is designed to carry the op-

erator only. No passengers.

3. The failure of motorists to detect and recognize motorcycles in traffic is the predominant cause of automobile/motorcycle accidents. Many accidents have been caused by an automobile driver who did not see the motorcycle. Making yourself conspicuous appears to be very effective in reducing the chance of this type of accident.

Therefore:

- Wear a brightly colored jacket.
 - Use extra caution when you are approaching and passing through intersections, since intersections are the most likely places for motorcycle accidents to occur.
 - Ride where other motorists can see you. Avoid riding in another motorist's blind spot.
 - Never maintain a motorcycle without proper knowledge. Contact an authorized motorcycle dealer to inform you on basic motorcycle maintenance. Certain maintenance can only be carried out by certified staff.
4. Many accidents involve inexperienced operators.
 - Make sure that you are qualified and that you only lend your motorcycle to other qualified operators.
 - Know your skills and limits. Staying within your limits may help you to avoid an accident.
 - We recommend that you practice riding your motorcycle until you have become thoroughly familiar with the motorcycle and all of its controls.
 5. Many accidents have been caused by error of the motorcycle operator. A typical error made by the operator is veering wide on a turn due to excessive speed or under cornering (insufficient lean angle for the speed). Never travel faster than warranted by conditions.
 6. Ride cautiously in unfamiliar areas. You may encounter hidden obstacles that could cause an accident.
 7. The posture of the operator is important for proper control. The operator should keep both hands on the handlebar and both feet on the operator footrests during operation to maintain control of the motorcycle.
 8. Never ride under the influence of alcohol or other drugs.
 9. Be sure the transmission is in neutral before starting the engine.

Protective Apparel

The majority of fatalities from motorcycle accidents are the result of head injuries. The use of a safety helmet is the single most critical factor in the prevention or reduction of head injuries.

1. Always wear an approved helmet.
2. Wear a face shield or goggles. Wind in your unprotected eyes could contribute to an impairment of vision that could delay seeing a hazard.
3. The use of a jacket, heavy boots, trousers, gloves, etc., is effective in preventing or reducing abrasions or lacerations.
4. Never wear loose-fitting clothes, otherwise they could catch on the control levers, footrests, or wheels and cause injury or an accident.
5. Always wear protective clothing that covers your legs, ankles, and feet. The engine or exhaust system become very hot during or after operation and can cause burns.

Avoid Carbon Monoxide Poisoning

All engine exhaust contains carbon monoxide, a deadly gas. Breathing carbon monoxide can cause headaches, dizziness, drowsiness, nausea, confusion, and eventually death.

Carbon Monoxide is a colorless, odorless, tasteless gas which may be present even if you do not see or smell any engine exhaust. Deadly levels of carbon monoxide can collect rapidly and you can quickly be overcome and unable to save yourself. Also, deadly levels of carbon monoxide can linger for hours or days in enclosed or poorly ventilated areas. If you experience any symptoms of carbon monoxide poisoning, leave the area immediately, get fresh air, and SEEK MEDICAL TREATMENT.

1. Do not run engine indoors. Even if you try to ventilate engine exhaust with fans or open windows and doors, carbon monoxide can rapidly reach dangerous levels.
2. Do not run engine in poorly ventilated or partially enclosed areas such as barns, garages, or carports.
3. Do not run engine outdoors where engine exhaust can be drawn into a building through openings such as windows and doors.

Genuine Yamaha Accessories

Choosing accessories for your vehicle is an important decision. Genuine Yamaha accessories, which are available only from a Yamaha dealer, have been designed, tested, and approved by Yamaha for use on your vehicle.

Many companies with no connection to Yamaha manufacture parts and accessories or offer other modifications for Yamaha vehicles. Yamaha is not in a position to test the products that these aftermarket companies produce. Therefore, Yamaha can neither endorse nor recommend the use of accessories not sold by Yamaha or modifications not specifically recommended by Yamaha, even if sold and installed by a Yamaha dealer.

Aftermarket Parts, Accessories, and Modifications

While you may find aftermarket products similar in design and quality to genuine Yamaha accessories, recognize that some aftermarket accessories or modifications are not suitable because of potential safety hazards to you or others. Installing aftermarket products or having other modifications performed to your vehicle that change any of the vehicle's design or operation characteristics can put you and others at greater risk of serious injury or death. You are responsible for injuries related to changes in the vehicle.

Keep the following guidelines in mind when mounting accessories.

1. Never install accessories that would impair the performance of your motorcycle. Carefully inspect the accessory before using it to make sure that it does not in any way reduce ground clearance or cornering clearance, limit suspension travel, steering travel or control operation.
 - Accessories fitted to the handlebar or the front fork area can create instability due to improper weight distribution. If accessories are added to the handlebar or front fork area, they must be as lightweight as possible and should be kept to a minimum.
 - Bulky or large accessories may seriously affect the stability of the motorcycle. Wind may attempt to lift the motorcycle, or the motorcycle may become unstable in cross winds.
 - Certain accessories can displace the operator from his or her normal riding position. This improper position limits the freedom of movement of the operator and may limit control ability, therefore, such accessories are not recommended.
2. Use caution when adding electrical accessories. If electrical accessories exceed the capacity of the motorcycle's electrical system, an electric failure could result, which could

cause a dangerous loss of lights or engine power.

Aftermarket Tires and Rims

The tires and rims that came with your motorcycle were designed to match the performance capabilities and to provide the best combination of handling, braking, and comfort. Other tires, rims, sizes, and combinations may not be appropriate. Refer to “CHECKING THE TIRES” on page 3-30 for tire specifications and more information on replacing your tires.

Transporting the Motorcycle

Be sure to observe following instructions before transporting the motorcycle in another vehicle.

1. Remove all loose items from the motorcycle.
2. Check that the fuel cock (if equipped) is in the “OFF” position and that there are no fuel leaks.
3. Point the front wheel straight ahead on the trailer or in the truck bed, and choke it in a rail to prevent movement.
4. Shift the transmission in gear (for models with a manual transmission).
5. Secure the motorcycle with tie-downs or suitable straps that are attached to solid parts of the motorcycle, such as the frame or upper front fork triple clamp (and not, for example, to rubber-mounted handlebars or turn signals, or parts that could break). Choose the location for the straps carefully so the straps will not rub against painted surfaces during transport.
6. The suspension should be compressed somewhat by the tie-downs, if possible, so that the motorcycle will not bounce excessively during transport.

EAM20203

ABOUT THE BATTERY

EAM30642

LITHIUM-ION BATTERY

The lithium-ion battery used in the vehicle features high energy density and has a high voltage (approximately three times that of nickel-cadmium (Ni-Cd) or nickel-hydrogen (Ni-MH) batteries), meaning it can be made both compact and lightweight.

Nickel-cadmium and nickel-hydrogen batteries have a memory effect that causes their capacity to degrade quickly as a result of repeated partial discharging and charging, so that they need to be completely discharged periodically. Lithium-ion batteries can be repeatedly partially charged without needing to be fully discharged.

EAM30644

LITHIUM-ION BATTERY DEGRADATION

The charge capacity of the lithium-ion battery gradually decreases over time and usage. The rate of capacity degradation varies based on the usage conditions.

TIP

- It is not necessary to use up the battery before charging.
- Storing the vehicle in an extremely hot or cold place could degrade the lithium-ion battery capacity more quickly.
- Even if the lithium-ion battery is not used, it discharges and degrades gradually over time.

EAM30643

RECYCLING THE BATTERY

Lithium-ion batteries can be recycled. If the capacity decreases excessively due to degradation, have a Yamaha dealer replace the battery. Always follow local regulations regarding the disposal of batteries.

For EU countries:

According to the European Guideline 2012/19/EU, electrical devices/tools that are no longer usable must be collected separately and disposed of in an environmentally correct manner.

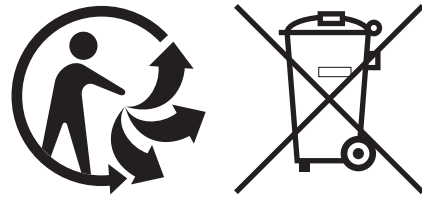

For FRANCE:



LOCATION OF IMPORTANT LABELS

EAM20085

LOCATION OF IMPORTANT LABELS

Please read the following important labels carefully before operating this vehicle.

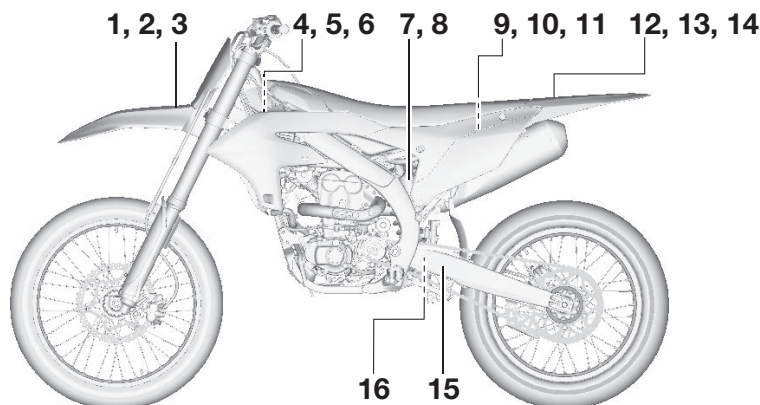

CAN

1

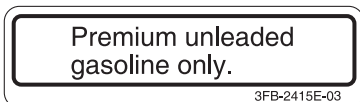

2

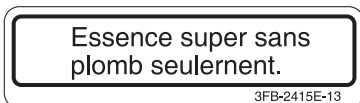

3

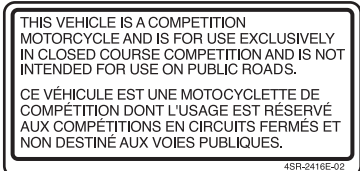

4

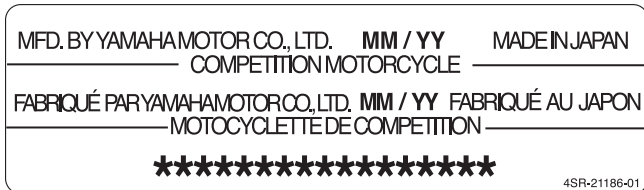

5

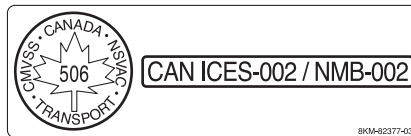

7

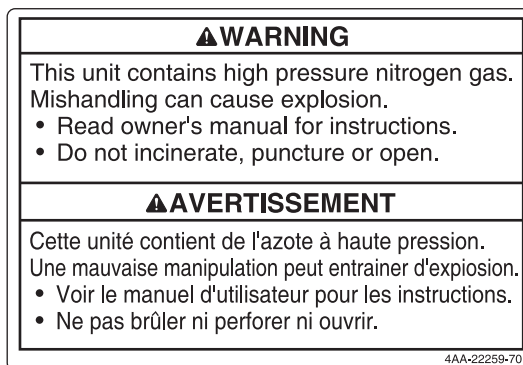

9

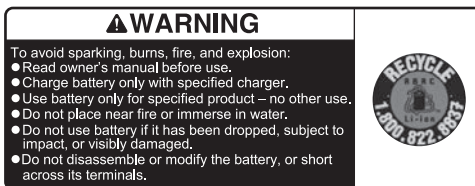

10



LOCATION OF IMPORTANT LABELS

12



15

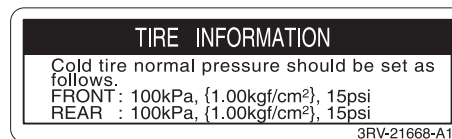

13



16



EUR

6



8



11



14

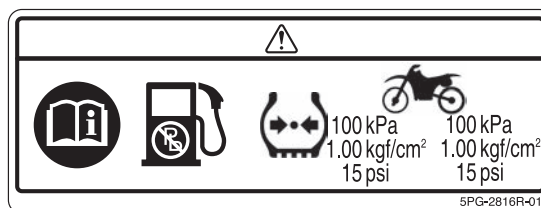

LOCATION OF IMPORTANT LABELS

AUS, NZL, ZAF

8



11



12

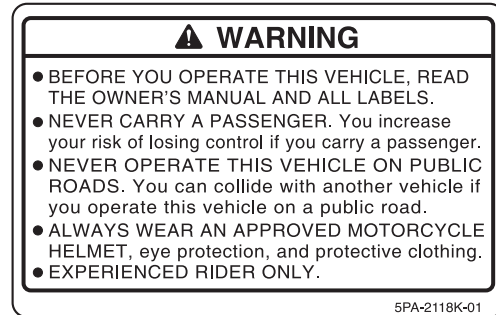

15

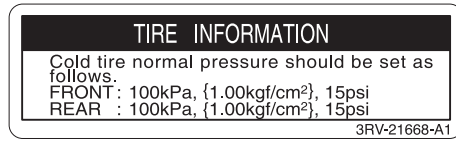

EAM20086

DESCRIPTION

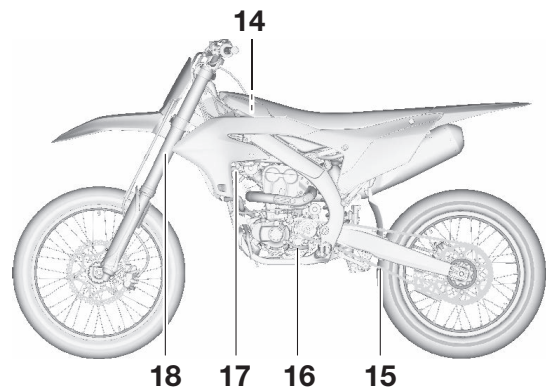
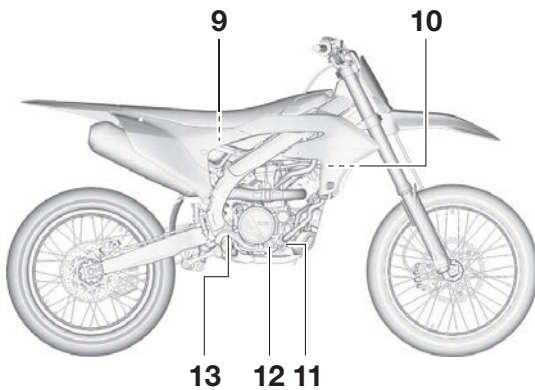
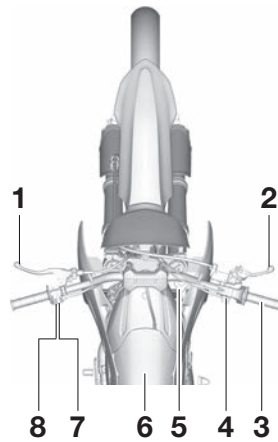

1. Clutch lever
2. Front brake lever
3. Throttle grip
4. Start switch
5. Radiator cap
6. Fuel tank cap
7. Engine stop switch
8. Mode switch
9. Fuel tank

10. Radiator
11. Coolant drain bolt
12. Oil level check window
13. Rear brake pedal
14. Air filter
15. Drive chain
16. Shift pedal
17. Starter knob
18. Front fork

TIP

Designs and specifications of the vehicle are subject to change without notice. Therefore, please note that the descriptions in this manual may be different from those for the vehicle you have purchased.

EAM20087

IDENTIFICATION

There are two significant reasons for knowing the serial number of your vehicle:

1. When ordering parts, you can give the number to your Yamaha dealer for positive identification of the model you own.
2. If your vehicle is stolen, the authorities will need the number to search for and identify your vehicle.

EAM30002

VEHICLE IDENTIFICATION NUMBER

The vehicle identification number “1” is stamped into the right side of the frame.

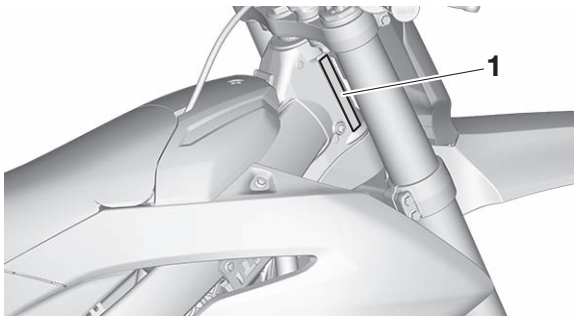

EAM30003

ENGINE SERIAL NUMBER

The engine serial number “1” is stamped into the lower left side of the engine.

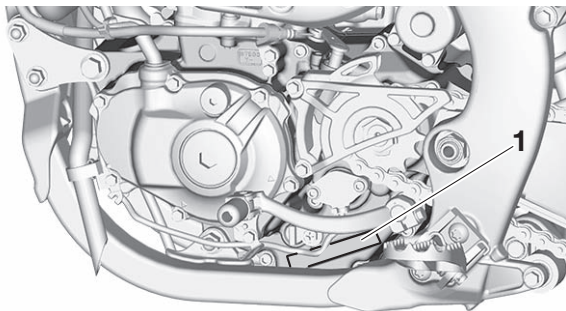

EAM20088

INCLUDED PARTS

EAM30372

SIDESTAND

This sidestand "1" is used to support only the machine when standing or transporting it.

EWA20260

⚠ WARNING

- Never apply additional force to the sidestand.
- Remove this sidestand before starting out.

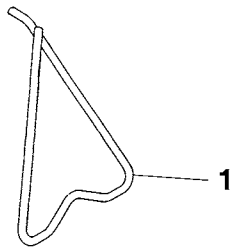

EAM30005

NIPPLE WRENCH

The nipple wrench "1" is used to tighten the spoke.

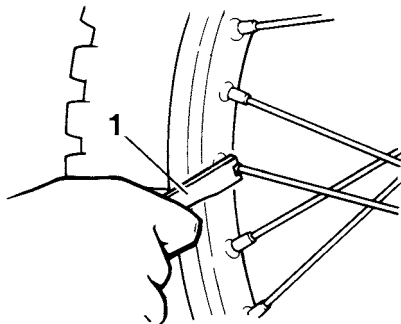

EAM30006

HANDLEBAR PROTECTOR

Install the handlebar protector "1" so that the mark "a" is facing the direction shown in the illustration.

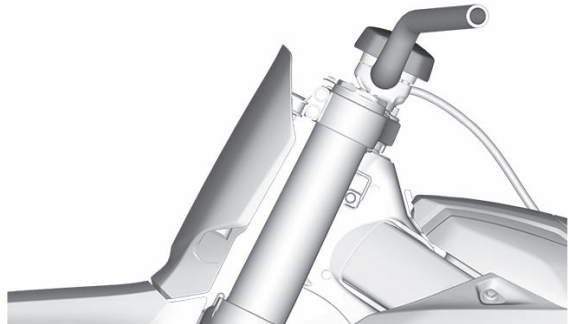
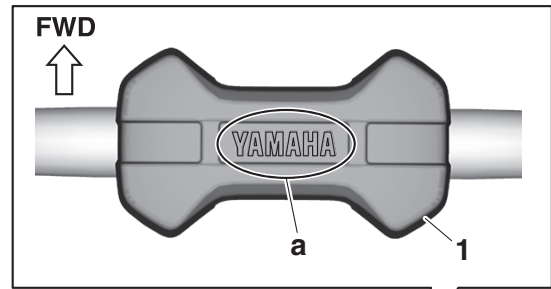

EAM30007

FUEL HOSE JOINT COVER

The fuel hose joint covers "1" are used to prevent mud, dust, and other foreign materials from entering the inside when the fuel hose is disconnected.

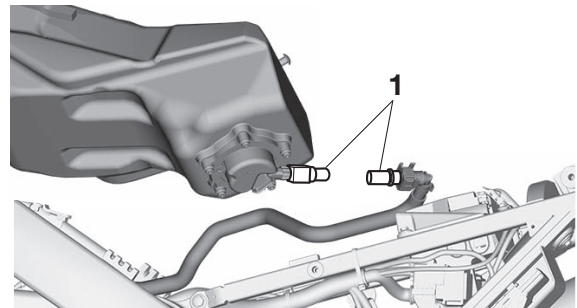

EAM30443

POWER TUNER

By downloading the Power Tuner app to your smartphone and wirelessly connecting to the CCU wireless network, you can adjust various vehicle settings.

EWA20460

⚠ WARNING

- Do not operate the engine in a closed area. The exhaust gas is poisonous.
- Never let flames near the servicing area.

ECA26050

NOTICE

- This application is designed for adjusting the settings on a standard vehicle. In case the engine specifications (muffler, com-

pression ratio, etc.) have been changed, the performance may not match to the actual settings.

- Do not run the engine with the smartphone carried with you. Otherwise, the smartphone could be damaged.

TIP

- Download the Power Tuner app from the Google© or Apple© store.
- For details about handling the smartphone, read the owner's manual of the smartphone.

Before connecting to the CCU wireless network (in case of initial use of the Power Tuner app)

1. Remove the bolts and side cover (left).

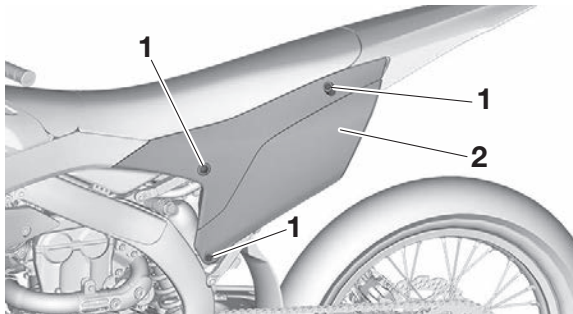

1. Bolt
2. Side cover (left)

2. Remove the CCU and record the CCU serial number.

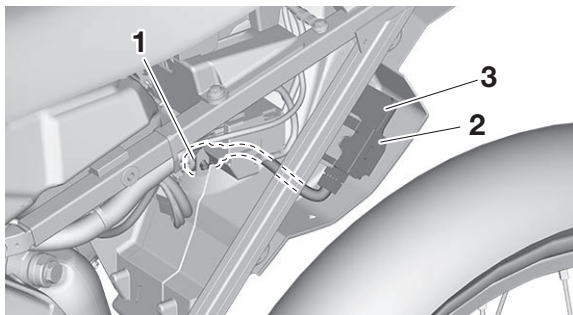

1. CCU coupler
2. Holder
3. CCU (Communication Control Unit)

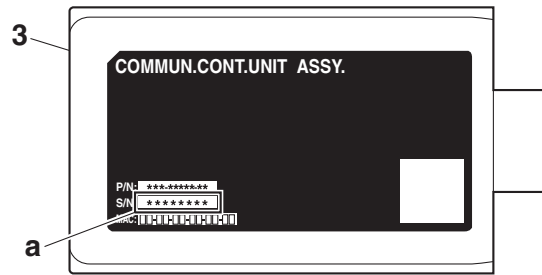

3. CCU (Communication Control Unit)

- a. CCU serial number

3. Install the removed CCU and side cover (left).

Connecting to the CCU wireless network

ECA26060

NOTICE

The CCU (Communication Control Unit) uses weak radio waves. The CCU may not work in the following situations.

- The CCU is placed in a location exposed to strong radio waves or other electromagnetic noise
- There are facilities nearby that are emitting strong radio waves (TV or radio towers, power plants, broadcasting stations, airports, etc.)
- You are carrying or using communication equipment such as radios or mobile phones in close proximity of the CCU
- The CCU is in contact with or covered by a metallic object
- Other vehicles equipped with a CCU are nearby

In such situations, move the CCU to another location and perform the operation again.

1. Turn on the smartphone.
2. For two minutes after the start switch is pressed or while the engine is running (the CCU is activated), input the CCU serial number into your smartphone and establish a wireless connection.

TIP

If the ECU has been activated while the engine is stopped:

In case of drive mode 1, the indicator light on the handlebar switch (left) will blink light in blue once every 4 seconds.

In case of drive mode 2, the indicator light on the handlebar switch (left) will light in blue.

3. Activate the Power Tuner app.

TIP

If the CCU wireless network cannot be detected, operate the start switch again.

EAM20089

IMPORTANT INFORMATION

EAM30009

PREPARATION FOR REMOVAL AND DISASSEMBLY

1. Before the jobs, completely remove mud, dust, and the like in order to prevent the entry of them into the inside during the jobs. Refer to "CARE" on page 1-23.

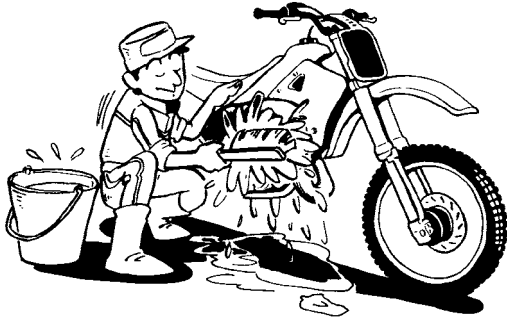

2. During disassembly, check and measure the required parts, and make a record of them so that you may refer to the record when installing them. Moreover, arrange gears, cylinders, pistons, and other parts for each section so as not to confuse or lose them.

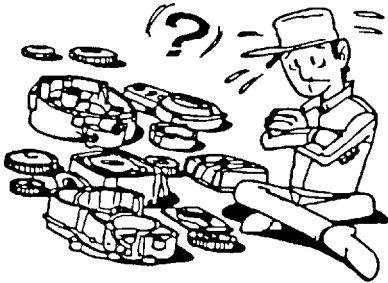

3. During disassembly, clean each of the parts, and store them in trays for each section.
4. Flammable. Keep servicing areas away from any source of fire.
5. During servicing, take special care not to receive an injury or a burn on the engine, the exhaust pipe, the silencer, or the like.
6. If coolant is left adhered to the chassis, paint and plating will be damaged. Therefore, rinse it out with water in good time.

EWA18970

WARNING

Coolant is potentially harmful and should be handled with special care.

- If it enters your eyes, wash it away with water enough and then get medical attention
- If it splashes on your skin or clothes, quickly wash it away with water and then with

soapy water.

- If it is swallowed, immediately induce vomiting and get medical attention.

EAM30010

REPLACEMENT PARTS

Make sure that the parts and grease or oil to be used for repair of the vehicle, including periodic replacement parts, are new YAMAHA genuine parts and recommended parts.

Do not use any used parts, because these may not be genuine though they have similar appearances or because the quality may be changed by aging.



INSTRUMENT AND CONTROL FUNCTIONS

EAM20181

INSTRUMENT AND CONTROL FUNCTIONS

EAM30182

ENGINE STOP SWITCH

The engine stop switch “1” is located on the left handlebar. Continue pushing the engine stop switch till the engine comes to a stop.

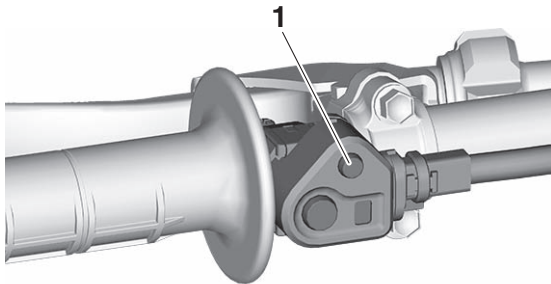

EAM30183

START SWITCH

The start switch “1” is located on the right handlebar. Push this switch to crank the engine with the starter.

TIP

- When the start switch is pushed, the indicator light on the handlebar switch (left) may illuminate orange for approx. 2 seconds as a self-check, but this is not a malfunction.
- Indicator light on the handlebar switch (left) flashes orange → Check or replace any faulty electrical part(s). Have a Yamaha dealer check the electrical system.

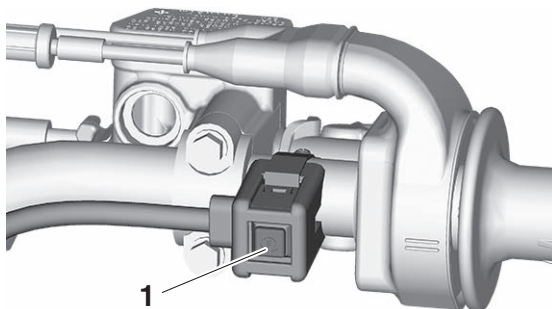

EAM30626

LAUNCH CONTROL SYSTEM

When the launch control system is operated, the ignition timing is delayed to reduce slipping at the rear wheel which occurs when the vehicle accelerates from a stationary position. This can be used to starting off in a stable manner on a slippery road surface. However, the effect may not be adequate de-

pending on the rider’s operations and road surface conditions.

How to operate

1. Put the gear into the neutral position.
2. Start the engine.
3. Push the mode switch “1” for more than one second to turn on the launch control system.

TIP

- When the launch control system is turned on, it automatically enters Rev. clip mode, and then the indicator light “2” will flash.
- The drive mode can be changed even when the launch control system is operating.
- When the indicator light flashes alternately purple and blue, drive mode 2 is selected.
- If the engine speed reaches the set rev limit speed, the indicator light will blink about 4 times per second.

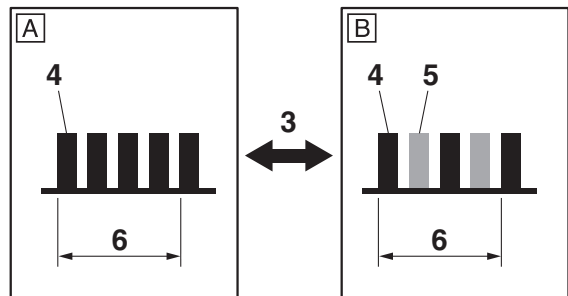
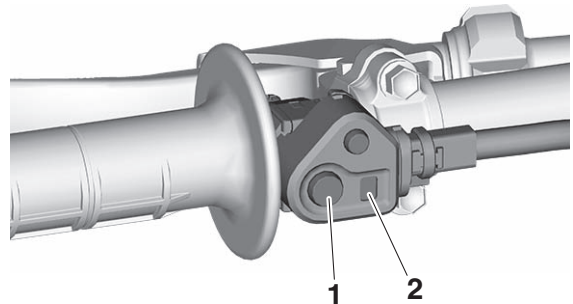

- A. Drive mode 1
- B. Drive mode 2

3. Push the mode switch
4. Purple
5. Blue
6. Approx. 1 second (4 flashes/second)

4. Put the gear into the 1st or 2nd gear for starting off.

TIP

- When starting off, the system automatically controls the launch.
- The drive mode can be changed even when the launch control system is operating.

INSTRUMENT AND CONTROL FUNCTIONS

- When the indicator light flashes alternately purple and blue, drive mode 2 is selected.

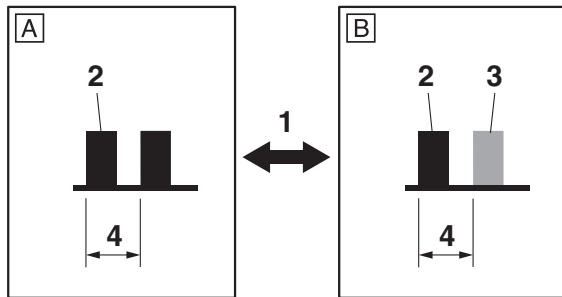

- A. Drive mode 1
B. Drive mode 2

1. Push the mode switch
 2. Purple
 3. Blue
 4. 1 second (1 flash/second)
5. After starting off, the launch control system will turn off automatically when the gear is shifted into the 3rd gear. The launch control system will also turn off when the engine is stopped or the gear is shifted into the 3rd gear or higher.

TIP

- When the launch control system is turned off, the indicator light “2” will stop flashing.
- In case the drive mode 1 is set, the indicator light blinks in blue once every 4 seconds if the ECU has been activated while the engine is stopped even if the launch control system is off.
- Indicator light on the handlebar switch (left) flashes orange → Check or replace any faulty electrical part(s). Have a Yamaha dealer check the electrical system.

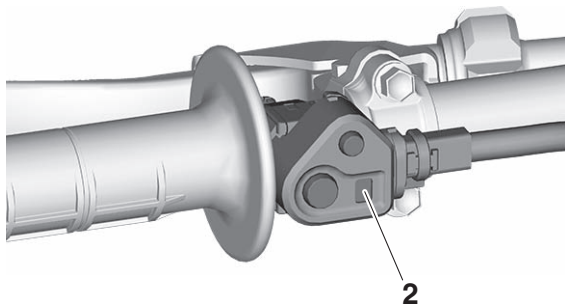

EAM30637

LAP TIME RECORD MODE

Lap time records can be measured by activating from the Power Tuner app.

When the mode switch “1” is pressed, the indicator light “2” will blink in blue and the measurement will start.

TIP

- When pressing the mode switch “1” again, the indicator light “2” will blink in blue and shift to the next lap time.
- Drive mode cannot be changed while in lap time record mode.
- Measurement results can be received and saved on the app.
- After the ECU has shut down, the lap time measurement will finish.

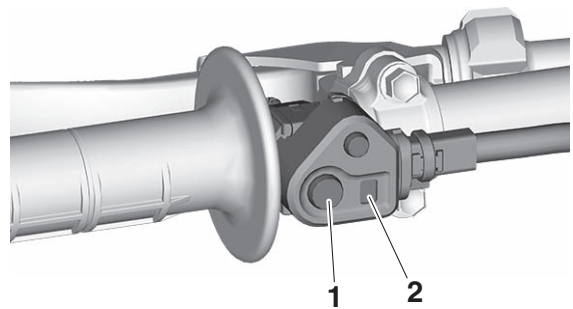

EAM30627

DRIVE MODE

Push the mode switch “1” to change between drive mode 1 and drive mode 2.

TIP

Indicator light on the handlebar switch (left) flashes orange → Check or replace any faulty electrical part(s). Have a Yamaha dealer check the electrical system.

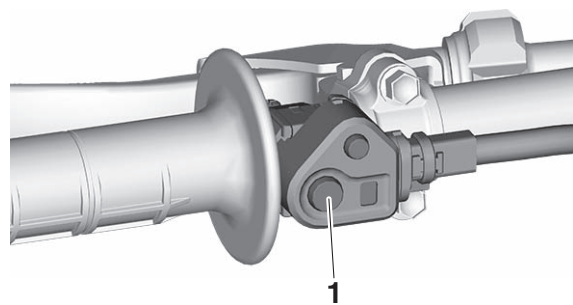

To change the drive mode

1. Shift to neutral.
2. Start the engine.
3. Push the mode switch “1”.

TIP

- As shipped from the factory, drive modes 1 and 2 are the same. You must use the Power Tuner app to adjust the map settings.
- When the indicator light “2” illuminates blue,

INSTRUMENT AND CONTROL FUNCTIONS

drive mode 2 is selected.

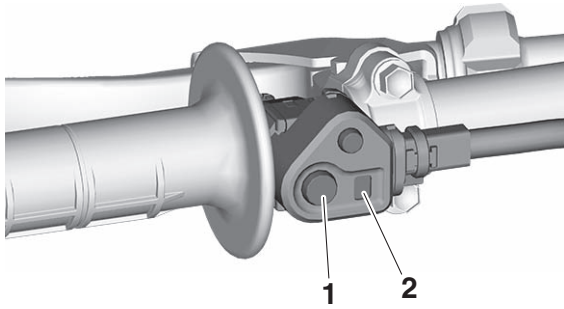

EAM30185

SHIFT PEDAL

The shift pedal “1” has adopted a method of 1 down & 4 ups (press-down & kick-ups). Press it down for N (neutral) to 1st, and kick it up for 2nd to 5th.

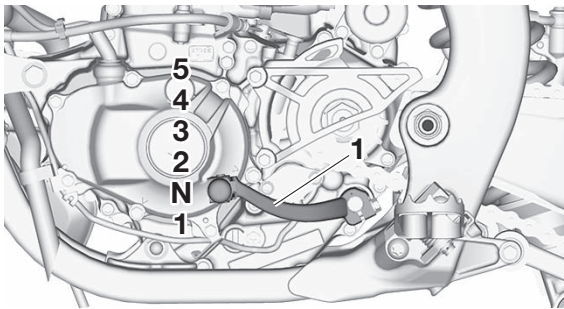

EAM30188

FRONT BRAKE LEVER

The front brake lever “1” is located on the right handlebar. Pull it toward the handlebar to activate the front brake.

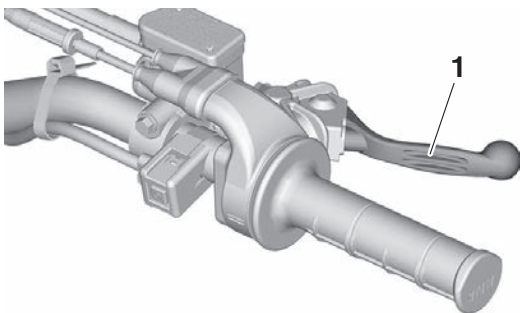

EAM30189

REAR BRAKE PEDAL

The rear brake pedal “1” is in the right of the chassis. Press down on the brake pedal to activate the rear brake.

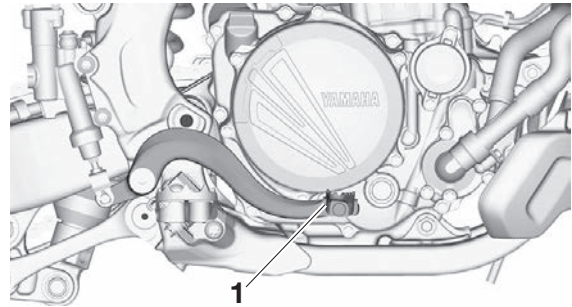

EAM30444

STARTER KNOB

Starting a cold engine requires a larger amount of intake air, which is supplied by the starter knob “1”.

Pushing the knob toward “a” turns ON the starter, resulting in a larger angle of throttle valve.

TIP

When operating the throttle grip in the closing direction, the starter knob “1” moves in the direction “b” as shown and returns to its original position.

EWA20470



WARNING

While handling the starter knob, take care not to burn yourself on exhaust pipes.

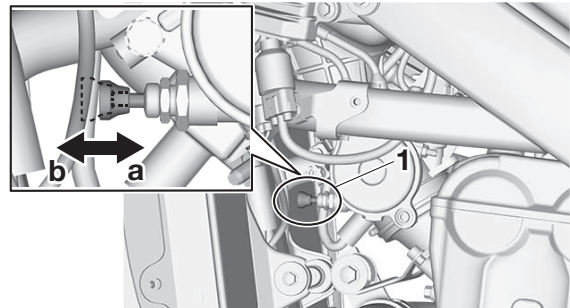

EAM30192

FUEL TANK CAP

Fuel tank cap is located under the sub-seat.

1. Loosen:

- Quick fastener “1”

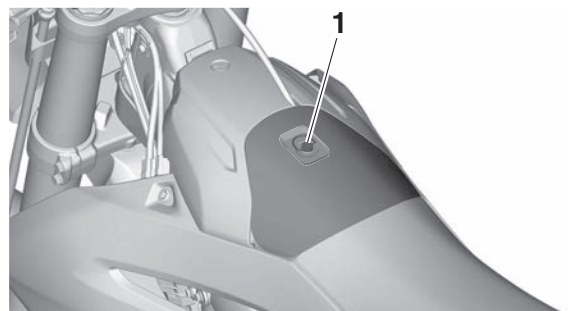

2. Remove the sub-seat “1” to open the fuel

INSTRUMENT AND CONTROL FUNCTIONS

tank cap “2”.

TIP

- When installing the sub-seat, make sure that the plastic band is not twisted.
 - When installing the sub-seat, push down the quick fastener, rotate it, and then secure the sub-seat with the quick fastener.
-

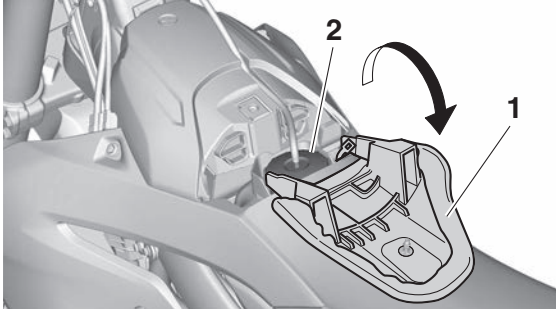

EAM20123

STARTING AND BREAK-IN

EAM30193

FUEL

Always use the recommended fuel as stated below. Also, be sure to use new gasoline the day of a race.



Recommended fuel
Unleaded gasoline (E10 acceptable)
Octane number (R+M)/2
91 or higher
Fuel tank capacity
6.2 L (1.6 US gal, 1.4 Imp.gal)

ECA24180

NOTICE

Use only unleaded gasoline. The use of leaded gasoline will cause severe damage to the engine internal parts such as valves, piston rings, and exhaust system, etc.

TIP

Your Yamaha engine has been designed to use unleaded gasoline with a pump octane number [(R+M)/2] of 91 or higher, or a research octane number of 95 or higher. If knocking (or pinging) occurs, use a gasoline of a different brand.

EWA19010

WARNING

- For refueling, be sure to stop the engine and use enough care not to spill any fuel. Also be sure to avoid refueling close to a fire.
- Refuel after the engine, exhaust pipe, etc. have cooled off.

Gasohol (For Canada)

There are two types of gasohol: gasohol containing ethanol and that containing methanol. Gasohol containing ethanol can be used if the ethanol content does not exceed 10 %. Gasohol containing methanol is not recommended by Yamaha because it can cause damage to the fuel system or vehicle performance problems.

EAM30196

STARTING A COLD ENGINE

1. Press the shift pedal to neutral.
2. Push the starter knob "1" completely.

TIP

- When the ambient temperature is 15 °C (59 °F) or below, use the starter knob.
- Do not operate the throttle grip when operat-

ing the starter knob.

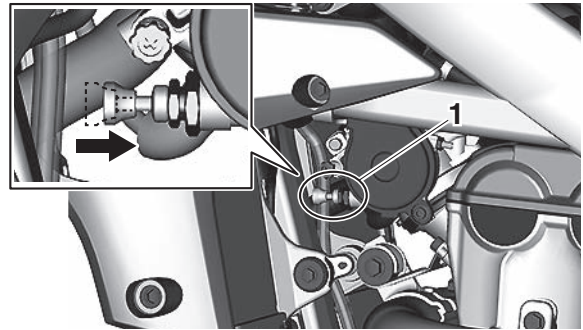

3. Start the engine by pushing the start switch. If the engine fails to start when using the start switch, release it, wait a few seconds, and then try again. Each starting attempt should be as short as possible to preserve the battery. Do not crank the engine more than 10 seconds on any one attempt.
4. When the engine starts running, warm this up one or two minutes at a steady speed (of 3000 to 5000 r/min), and then return the starter knob to its original position.

TIP

When operating the throttle grip in the closing direction, the starter knob "1" moves in the direction as shown and returns to its original position.

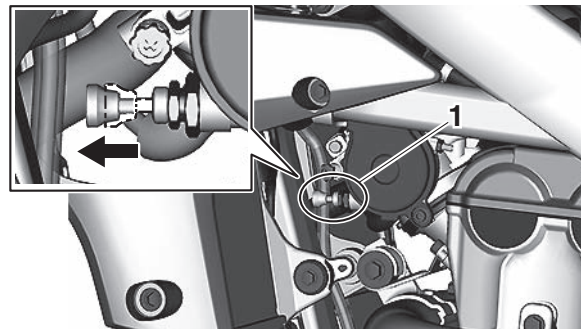

EWA19030

WARNING

Since exhaust gas contains harmful ingredients, do not start or warm it up at an illventilated place or a closed narrow place.

5. To stop the engine, push the engine stop switch "1".

TIP

Continue pushing the engine stop switch till the engine comes to a full stop.

STARTING AND BREAK-IN

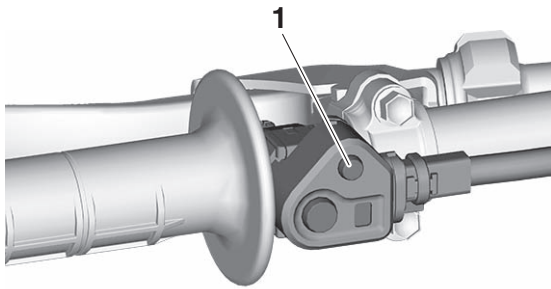

EAM30197

STARTING A WARM ENGINE

Follow the same procedure as for starting a cold engine with the exception that the starter is not required when the engine is warm.

TIP

If the engine fail to start, fully open the throttle grip and push the start switch few seconds to clear the engine of the rich air-fuel mixture retained in it.

EAM30198

BREAK-IN PROCEDURES

A break-in is important so that rotating portion, sliding surfaces, and mounted areas may fit one another, and that the rider may become accustomed to the machine.

ECA25811

NOTICE

Before running, do maintenance on the air filter element.

1. After warming up the engine, drive it for about 20 minutes at a throttle opening of 1/2 or less.

TIP

This model is equipped with an engine auto-stop system. The engine stops automatically if left idling for 7 minutes. If the engine stops, push the start switch to restart the engine.

2. Make a pit stop, and check mounted areas for looseness, oil leaks, or other problems.
3. Then, drive it for about 40 minutes at a throttle opening of 3/4 or less.
4. Make a pit stop again, and thoroughly check mounted areas for looseness, oil leaks, or other problems. Thorough checks and adjustments are required in particular for stretch of cables, free play of the brake, stretch of the drive chain, looseness of the spoke, and so on.

ECA25821

NOTICE

After a break-in or after each race, always

check the points shown in “TORQUE-CHECK POINTS” for tightening torques and retighten them.

Also when the following parts are replaced, a break-in is required.

- **Cylinder and Crankshaft:** A break-in is required for about an hour.
- **Piston, Piston ring, Valve, Camshaft, and Gear:** A break-in is required for about 30 minutes at a throttle opening of 1/2 or less. Observe the condition of the engine carefully during a break-in.

For checkpoints for a break-in, see “MAINTENANCE AFTER BREAK-IN”. If any problem is found, immediately stop the engine and make a checkup.

EAM30468

ENGINE STARTING PRECAUTION

Make sure the transmission is in neutral or be sure to pull the clutch lever before pressing the start switch.

EWA20540

WARNING

If the clutch lever is not pulled and the start switch is pressed with the transmission in gear, the starter motor will cause the rear wheel to spin, which may cause injury.

EAM20124

MAINTENANCE AFTER BREAK-IN

After a break-in, perform careful maintenance to get ready for the next practice or race.

Refer to “PRE-OPERATION INSPECTION AND MAINTENANCE” on page 3-6.

EAM30199

MAJOR MAINTENANCE

1. For the engine

- Leaks around the engine
Check for pressure leaks from the cylinder head or the cylinder, oil leaks from the crankcase or the case cover, leaks from the coolant system, and other leaks.
- Check that the valve, the cylinder head, the cylinder, the piston, and the piston ring fit one another, and that contact between the valve and the cylinder head, and that between the cylinder and the piston are correct.
- Engine oil change
Drain the oil, and check for dirt and foreign materials such as metal chips. (If any foreign material is mixed, disassemble and check the crankcase.)
Pour the specified amount of the recommended oil.
- Generator
Check for looseness in mounted areas of the generator rotor and the stator coil assembly. Check that the connector is not being disconnected.
- Silencer
Check the main body and stay for cracks. Check for leaks.
- Mounting bolts and nuts
Check for looseness in mounted areas of parts, as well as engine mounting bolts and engine brackets.

2. For the chassis

- Check welds and mounted areas of the frame, the swingarm, the link, the bracket, and so on, for looseness and cracks.
- Wheel(s)
Check the wheel for runout. Check the spoke for looseness.
- Brake(s)
Check the brake disc mounting bolt for looseness.
Check that the reservoir contains the specified amount of brake fluid. Check for leaks.
- Cable
Grease and adjust cables.

- Drive chain
Lubricate the drive chain and adjust its tension.
- Fuel tank
Clean the inside of the fuel tank. Check for leaks.
- Suspension
Check for oil leaks in the front fork or the rear shock absorber. Check that the mounted conditions are good.
- Sprocket
Check for looseness in the sprocket mounted on the rear wheel.
- Mounting bolts and nuts
Check mounted areas for looseness.

ECA25831

NOTICE

After a break-in or before each race, always check the points shown in “TORQUE-CHECK POINTS” for tightening torques and retighten them.

- Greasing and oiling
Always grease or oil the specified points.

EAM30195

AIR FILTER MAINTENANCE

Apply the Yamaha foam air filter oil or other quality foam air filter oil to the element. (Excess oil in the element may adversely affect engine starting.) Refer to “CLEANING THE AIR FILTER ELEMENT” on page 3-12.

TORQUE-CHECK POINTS

EAM20125

TORQUE-CHECK POINTS

Frame construction		Fuel tank to frame	
		Frame to rear frame	
		Frame to engine protector	
Engine mounting		Frame to engine	
		Engine bracket to engine	
		Engine bracket to frame	
Seat		Seat to rear fender	
Steering		Steering stem to handlebar	
		Steering stem to frame	
		Steering stem to upper bracket	
Suspension		Front	Steering stem to front fork
			Front fork to upper bracket
Suspension		Rear	Link
			Front fork to lower bracket
			Assembly of links
			Link to frame
			Link to rear shock absorber
			Link to swingarm
			Mounting of rear shock absorber
Mounting of swingarm			
Wheel(s)		Mounting of wheel	Front
			Tightening of wheel axle
			Tightening of axle holder
			Tightening of spoke nipple
			Rear
			Tightening of wheel axle
		Wheel to rear wheel sprocket	
		Tightening of spoke nipple	
		Brake(s)	
Brake disc to wheel			
Tightening of union bolt			
Brake master cylinder to handlebar			
Tightening of bleed screw			
Tightening of brake hose holder			
Rear	Brake pedal to frame		
	Brake disc to wheel		
	Tightening of union bolt		
	Brake master cylinder to frame		
	Tightening of bleed screw		
	Tightening of brake hose holder		
Fuel system		Fuel pump to fuel tank	

TORQUE-CHECK POINTS

Shift pedal	Shift pedal to shift shaft
Plastic cover	Tightening of front fender
	Tightening of fork leg protector
	Tightening of shroud
	Tightening of side cover
	Tightening of rear fender
	Tightening of mud flap
	Tightening of rear brake caliper cover

TIP

Concerning the tightening torque, refer to "TIGHTENING TORQUES" on page 2-8.

EAM20126

MOTORCYCLE CARE AND STORAGE

EAM30200

CARE

While the open design of a motorcycle reveals the attractiveness of the technology, it also makes it more vulnerable. Rust and corrosion can develop even if high-quality components are used. A rusty exhaust pipe may go unnoticed on a car, however, it detracts from the overall appearance of a motorcycle. Frequent and proper care does not only comply with the terms of the warranty, but it will also keep your motorcycle looking good, extend its life and optimize its performance.

Before cleaning

TIP

Be sure to confirm that the vehicle is completely cooled.

1. Block or cover the following parts with suitable measures.
 - Air duct "1"
(other gaps around shrouds and seats)
 - Drain hole on the cylinder head (right side) "2"
 - Hole under the water pump housing "3"
 - Muffler outlet "4"

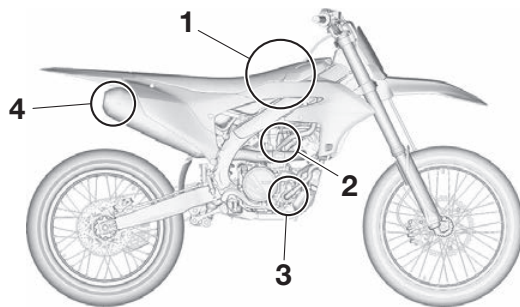

2. Make sure that all caps and covers as well as all electrical couplers and connectors, including the spark plug cap, are tightly installed.
3. Remove extremely stubborn dirt, like oil burnt onto the crankcase, with a degreasing agent and a brush, but never apply such products onto seals, gaskets, sprockets, the drive chain and wheel axles. Always rinse the dirt and degreaser off with water.

Cleaning

ECA26730

NOTICE

- Avoid using strong acidic wheel cleaners,

especially on spoked wheels. If such products are used on hard-to-remove dirt, do not leave the cleaner on the affected area any longer than instructed. Also, thoroughly rinse the area off with water, immediately dry it, and then apply a corrosion protection spray.

- Improper cleaning can damage plastic parts (such as cowlings, panels, windshields, headlight lenses, meter lenses, etc.) and the mufflers. Use only a soft, clean cloth or sponge with water to clean plastic. However, if the plastic parts cannot be thoroughly cleaned with water, diluted mild detergent with water may be used. Be sure to rinse off any detergent residue using plenty of water, as it is harmful to plastic parts.
- Do not use any harsh chemical products on plastic parts. Be sure to avoid using cloths or sponges which have been in contact with strong or abrasive cleaning products, solvent or thinner, fuel (gasoline), rust removers or inhibitors, brake fluid, antifreeze or electrolyte.
- For motorcycles equipped with a windshield: Do not use strong cleaners or hard sponges as they will cause dulling or scratching. Some cleaning compounds for plastic may leave scratches on the windshield. Test the product on a small hidden part of the windshield to make sure that it does not leave any marks. If the windshield is scratched, use a quality plastic polishing compound after washing.
- When cleaning using either a high-pressure cleaning machine or a water hose, do not direct the water jet toward the following areas: (Otherwise, it could cause either damage due to the water pressure or malfunction due to water entry.)
 - Wheels or swing arm bearings
 - Fork seals or brake seals
 - Electrical parts, such as couplers, switches, battery, etc.
 - Muffler or hoses
 - Air cleaner intake port
- Do not clean using a water jet with the seat or cover removed.

MOTORCYCLE CARE AND STORAGE

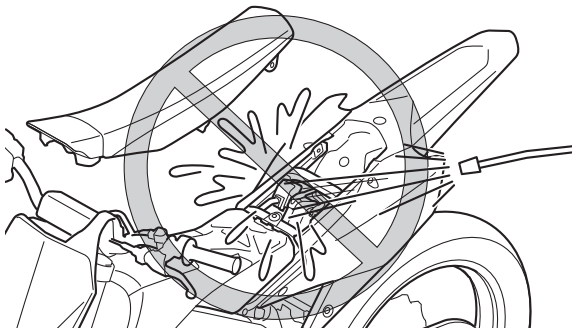

After normal use

Remove dirt with warm water, a mild detergent, and a soft, clean sponge, and then rinse thoroughly with clean water. Use a toothbrush or bottlebrush for hard-to-reach areas. Stubborn dirt and insects will come off more easily if the area is covered with a wet cloth for a few minutes before cleaning.

After riding in the rain, near the sea or on salt-sprayed roads

Since sea salt or salt sprayed on roads during winter are extremely corrosive in combination with water, carry out the following steps after each ride in the rain, near the sea or on salt-sprayed roads.

TIP

Salt sprayed on roads in the winter may remain well into spring.

1. Clean the motorcycle with cold water and a mild detergent, after the engine has cooled down.

NOTICE: Do not use warm water since it increases the corrosive action of the salt.

2. Apply a corrosion protection spray on all metal, including chrome- and nickel-plated, surfaces to prevent corrosion.

After cleaning

1. Dry the motorcycle with a chamois or an absorbing cloth.
2. Immediately dry the drive chain and lubricate it to prevent it from rusting.
3. Use a chrome polish to shine chrome, aluminum and stainless- steel parts, including the exhaust system. (Even the thermally induced discoloring of stainless- steel exhaust systems can be removed through polishing.)
4. To prevent corrosion, it is recommended to apply a corrosion protection spray on all metal, including chrome- and nickel-plated, surfaces.
5. Use spray oil as a universal cleaner to remove any remaining dirt.

6. Touch up minor paint damage caused by stones, etc.
7. Wax all painted surfaces.
8. Let the motorcycle dry completely before storing or covering it.

EWA19050

WARNING

Contaminants on the brakes or tires can cause loss of control.

- Make sure that there is no oil or wax on the brakes or tires.
- If necessary, clean the brake discs and brake linings with a regular brake disc cleaner or acetone, and wash the tires with warm water and a mild detergent. Before riding at higher speeds, test the motorcycle's braking performance and cornering behavior.

ECA24240

NOTICE

- Apply spray oil and wax sparingly and make sure to wipe off any excess.
- Never apply oil or wax to any rubber and plastic parts, but treat them with a suitable care product.
- Avoid using abrasive polishing compounds as they will wear away the paint.

TIP

- Consult a Yamaha dealer for advice on what products to use.
- Washing, rainy weather or humid climates can cause the headlight lens to fog. Turning the headlight on for a short period of time will help remove the moisture from the lens.

EAM30201

STORAGE

Short-term

Always store your motorcycle in a cool, dry place and, if necessary, protect it against dust with a porous cover. Be sure the engine and the exhaust system are cool before covering the motorcycle.

ECA24250

NOTICE

- Storing the motorcycle in a poorly ventilated room or covering it with a tarp, while it is still wet, will allow water and humidity to seep in and cause rust.
- To prevent corrosion, avoid damp cellars, stables (because of the presence of ammonia) and areas where strong chemicals are

stored.

Long-term

Before storing your motorcycle for several months:

1. Follow all the instructions in the “CARE” on page 1-23.
2. Fill up the fuel tank and add fuel stabilizer (if available) to prevent the fuel tank from rusting and the fuel from deteriorating.
3. Perform the following steps to protect the cylinder, piston rings, etc. from corrosion.
 - a. Remove the spark plug cap and spark plug.
 - b. Pour a teaspoonful of engine oil into the spark plug bore.
 - c. Install the spark plug cap onto the spark plug, and then place the spark plug on the cylinder head so that the electrodes are grounded. (This will limit sparking during the next step.)
 - d. Turn the engine over several times with the starter. (This will coat the cylinder wall with oil.)
 - e. Remove the spark plug cap from the spark plug, and then install the spark plug and the spark plug cap. **WARNING! To prevent damage or injury from sparking, make sure to ground the spark plug electrodes while turning the engine over.**
4. Lubricate all control cables and the pivoting points of all levers and pedals as well as of the sidestand/centerstand.
5. Check and, if necessary, correct the tire air pressure, and then lift the motorcycle so that both of its wheels are off the ground. Alternatively, turn the wheels a little every month in order to prevent the tires from becoming degraded in one spot.
6. Cover the muffler outlet with a plastic bag to prevent moisture from entering it.
7. Remove the battery and fully charge it. Store it in a cool, dry place and charge it once a month. Do not store the battery in an excessively cold or warm place [less than 0 °C (32 °F) or more than 65 °C (149 °F)]. For more information on storing the battery, “CHECKING AND CHARGING THE BATTERY” on page 7-1.

TIP

Make any necessary repairs before storing the motorcycle.

MOTORCYCLE CARE AND STORAGE

SPECIFICATIONS

GENERAL SPECIFICATIONS	2-1
ENGINE SPECIFICATIONS	2-2
CHASSIS SPECIFICATIONS	2-4
ELECTRICAL SPECIFICATIONS	2-7
TIGHTENING TORQUES	2-8
GENERAL TIGHTENING TORQUE SPECIFICATIONS.....	2-8
ENGINE TIGHTENING TORQUES.....	2-9
CHASSIS TIGHTENING TORQUES.....	2-12

GENERAL SPECIFICATIONS

EAM20127

GENERAL SPECIFICATIONS

Model

Model

BMF1 (CAN)
BMF2 (AUT, BEL, CHE, CYP, CZE, DEU, DNK, ESP, FIN, FRA, GBR, GRC, HRV, HUN, IRL, ITA, NLD, NOR, POL, PRT, SVK, SVN, SWE, TUR)
BMF4 (AUS, NZL, ZAF)
BMF6 (CAN)
BMF7 (AUT, BEL, CHE, CYP, CZE, DEU, DNK, ESP, FIN, FRA, GBR, GRC, HRV, HUN, IRL, ITA, NLD, NOR, POL, PRT, SVK, SVN, SWE, TUR)
BMF9 (AUS, NZL)

Dimensions

Overall length	2180 mm (85.8 in)
Overall width	825 mm (32.5 in)
Overall height	1275 mm (50.2 in)
Seat height	970 mm (38.2 in)
Wheelbase	1475 mm (58.1 in)
Ground clearance	350 mm (13.78 in)

Weight

Curb weight	105 kg (231 lb)
-------------	-----------------

ENGINE SPECIFICATIONS

EAM20128

ENGINE SPECIFICATIONS

Engine

Combustion cycle	4-stroke
Cooling system	Liquid cooled
Valve train	DOHC
Displacement	250 cm ³
Number of cylinders	Single cylinder
Bore × stroke	77.0 × 53.6 mm (3.03 × 2.11 in)
Compression ratio	13.8 : 1
Starting system	Electric starter

Fuel

Recommended fuel	Unleaded gasoline (E10 acceptable)
Octane number (RON)	95
Fuel tank capacity	6.2 L (1.6 US gal, 1.4 Imp.gal)

Engine oil

Recommended brand	YAMALUBE
SAE viscosity grades	10W-40, 10W-50, 15W-40, 20W-40 or 20W-50
Recommended engine oil grade	API service SG type or higher, JASO standard MA
Lubrication system	Wet sump
Engine oil quantity	
Oil change	0.73 L (0.77 US qt, 0.64 Imp.qt)
With oil filter removal	0.75 L (0.79 US qt, 0.66 Imp.qt)
Quantity (disassembled)	0.95 L (1.00 US qt, 0.84 Imp.qt)

Cooling system

Coolant quantity	
Radiator (including all routes)	0.94 L (0.99 US qt, 0.83 Imp.qt)

Spark plug(s)

Manufacturer/model	NGK/LMAR9E-J
Spark plug gap	0.6–0.7 mm (0.024–0.028 in)

Valve

Valve clearance (cold)	
Intake	0.12–0.19 mm (0.0047–0.0075 in)
Exhaust	0.17–0.24 mm (0.0067–0.0094 in)

Clutch

Clutch type	Wet, multiple-disc
Clutch lever free play	7.0–12.0 mm (0.28–0.47 in)
Friction plate thickness	2.70–2.90 mm (0.106–0.114 in)
Wear limit	2.60 mm (0.102 in)
Plate quantity	8 pcs
Clutch plate thickness	1.50–1.70 mm (0.059–0.067 in)
Plate quantity	7 pcs
Warping limit	0.10 mm (0.004 in)
Clutch spring free length	46.20 mm (1.82 in)
Clutch spring free length limit	43.89 mm (1.73 in)
Push rod bending limit	0.30 mm (0.012 in)

Drivetrain

Primary reduction ratio	3.353 (57/17)
-------------------------	---------------

ENGINE SPECIFICATIONS

Transmission type	Constant mesh 5-speed
Gear ratio	
1st	2.143 (30/14)
2nd	1.750 (28/16)
3rd	1.444 (26/18)
4th	1.222 (22/18)
5th	1.042 (25/24)
Secondary reduction ratio	3.846 (50/13)
Final drive	Chain

Air filter

Air filter element	Wet element
Air filter oil grade	Yamaha foam air filter oil or other quality foam air filter oil

Idling condition

Engine idling speed	1900–2100 r/min
Coolant temperature	70–80 °C (158–176 °F)
Throttle grip free play	3.0–6.0 mm (0.12–0.24 in)

CHASSIS SPECIFICATIONS

EAM20129

CHASSIS SPECIFICATIONS

Chassis

Caster angle	26.9 °
Trail	119 mm (4.7 in)

Front wheel

Wheel type	Spoke wheel
Rim size	21x1.6

Rear wheel

Wheel type	Spoke wheel
Rim size	19x2.15

Front tire

Type	With tube
Size	80/100-21 51M
Manufacturer/model	DUNLOP/MX33F

Rear tire

Type	With tube
Size	110/90-19 62M
Manufacturer/model	DUNLOP/MX33

Tire air pressure (measured on cold tires)

Front	100 kPa (1.00 kgf/cm ² , 15 psi)
Rear	100 kPa (1.00 kgf/cm ² , 15 psi)

Front brake

Type	Hydraulic single disc brake
Brake pad lining thickness limit	1.0 mm (0.04 in)
Specified brake fluid	DOT 4

Rear brake

Type	Hydraulic single disc brake
Brake pad lining thickness limit	1.0 mm (0.04 in)
Specified brake fluid	DOT 4

Front suspension

Type	Telescopic fork
Spring	Coil spring
Shock absorber	Hydraulic damper
Wheel travel	310 mm (12.2 in)
Fork spring free length limit	492.0 mm (19.37 in)
Inner tube bending limit	0.2 mm (0.01 in)
Recommended oil	Yamaha Suspension Oil S1
Quantity (left)	486.0 cm ³ (16.43 US oz, 17.14 Imp.oz)
Quantity (right)	486.0 cm ³ (16.43 US oz, 17.14 Imp.oz)
Rebound damping	
Adjusting system	Mechanical adjustable type
Unit for adjustment	Click
Adjustment value from the start position (Soft)	20

CHASSIS SPECIFICATIONS

Adjustment value from the start position (STD)	7 (CAN) 9 (AUS, AUT, BEL, CHE, CYP, CZE, DEU, DNK, ESP, FIN, FRA, GBR, GRC, HRV, HUN, IRL, ITA, NLD, NOR, NZL, POL, PRT, SVK, SVN, SWE, TUR, ZAF)
Adjustment value from the start position (Hard)	0
Compression damping	
Adjusting system	Mechanical adjustable type
Unit for compression damping adjustment	Click
Adjustment value from the start position (Soft)	20
Adjustment value from the start position (STD)	10 (CAN) 11 (AUS, AUT, BEL, CHE, CYP, CZE, DEU, DNK, ESP, FIN, FRA, GBR, GRC, HRV, HUN, IRL, ITA, NLD, NOR, NZL, POL, PRT, SVK, SVN, SWE, TUR, ZAF)
Adjustment value from the start position (Hard)	0

Rear suspension	
Type	Swingarm (link suspension)
Spring	Coil spring
Shock absorber	Gas-hydraulic damper
Wheel travel	313 mm (12.3 in)
Spring preload	
Adjusting system	Mechanical adjustable type
Adjustment value (Soft)	1.5 mm (0.06 in)
Adjustment value (STD)	5.0 mm (0.20 in)
Adjustment value (Hard)	18.0 mm (0.71 in)
Rebound damping	
Adjusting system	Mechanical adjustable type
Unit for adjustment	Click
Adjustment value from the start position (Soft)	30
Adjustment value from the start position (STD)	10 (CAN) 9 (AUS, AUT, BEL, CHE, CYP, CZE, DEU, DNK, ESP, FIN, FRA, GBR, GRC, HRV, HUN, IRL, ITA, NLD, NOR, NZL, POL, PRT, SVK, SVN, SWE, TUR, ZAF)
Adjustment value from the start position (Hard)	0
Compression damping	
Adjusting system	Mechanical adjustable type
Fast compression damping	
Unit for adjustment	Turn
Adjustment value from the start position (Soft)	2
Adjustment value from the start position (STD)	1+1/4 (CAN) 7/8 (AUS, AUT, BEL, CHE, CYP, CZE, DEU, DNK, ESP, FIN, FRA, GBR, GRC, HRV, HUN, IRL, ITA, NLD, NOR, NZL, POL, PRT, SVK, SVN, SWE, TUR, ZAF)

CHASSIS SPECIFICATIONS

Adjustment value from the start position (Hard)	0
Slow compression damping	
Unit for adjustment	Click
Adjustment value from the start position (Soft)	20
Adjustment value from the start position (STD)	10 (CAN) 11 (AUS, AUT, BEL, CHE, CYP, CZE, DEU, DNK, ESP, FIN, FRA, GBR, GRC, HRV, HUN, IRL, ITA, NLD, NOR, NZL, POL, PRT, SVK, SVN, SWE, TUR, ZAF)
Adjustment value from the start position (Hard)	0

Drive chain

Size	520
Chain type	Non-sealed type
Number of links	114
Drive chain slack (Maintenance Stand)	50.0–60.0 mm (1.97–2.36 in)
15-link length limit	242.9 mm (9.56 in)

ELECTRICAL SPECIFICATIONS

EAM20130

ELECTRICAL SPECIFICATIONS

Battery

Model	BR98
Voltage, capacity	12 V, 2.4 Ah (5 HR)

Fuse(s)

Main fuse	15.0 A
Spare fuse	15.0 A

EAM20131

TIGHTENING TORQUES

EAM30205

GENERAL TIGHTENING TORQUE SPECIFICATIONS

This chart specifies tightening torques for standard fasteners with a standard ISO thread pitch. Tightening torque specifications for special components or assemblies are provided for each chapter of this manual. To avoid warpage, tighten multi-fastener assemblies in a criss-cross pattern and progressive stages until the specified tightening torque is reached. Unless otherwise specified, tightening torque specifications require clean, dry threads. Components should be at room temperature.

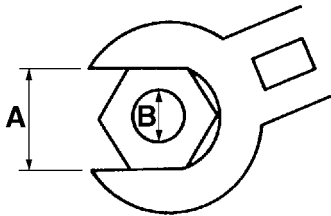

- A. Distance between flats
- B. Outside thread diameter

A (nut)	B (bolt)	General tightening torques		
		N·m	kgf·m	lb·ft
10 mm	6 mm	6	0.6	4.4
12 mm	8 mm	15	1.5	11
14 mm	10 mm	30	3.0	22
17 mm	12 mm	55	5.5	41
19 mm	14 mm	85	8.5	63
22 mm	16 mm	130	13.0	96









TIGHTENING TORQUES

EAM30203















ENGINE TIGHTENING TORQUES

TIP





△ - marked portion shall be checked for torque tightening after break-in or before each race.

Item	Thread size	Q'ty	Tightening torques	Remarks
Camshaft cap bolt	M6	8	10 N·m (1.0 kgf·m, 7.4 lb·ft)	
Spark plug	M10	1	13 N·m (1.3 kgf·m, 9.6 lb·ft)	
Oil passage plug (cylinder head)	M6	1	10 N·m (1.0 kgf·m, 7.4 lb·ft)	
Cylinder head bolt	M9	4	See TIP.	
Cylinder head nut	M6	2	10 N·m (1.0 kgf·m, 7.4 lb·ft)	
Cylinder head cover bolt	M6	2	10 N·m (1.0 kgf·m, 7.4 lb·ft)	
Cylinder head stud bolt (exhaust pipe)	M6	2	7 N·m (0.7 kgf·m, 5.2 lb·ft)	
Stud bolt (Cylinder head cover)	M6	1	10 N·m (1.0 kgf·m, 7.4 lb·ft)	
Cylinder bolt	M6	1	10 N·m (1.0 kgf·m, 7.4 lb·ft)	
Oil pressure check bolt	M6	1	10 N·m (1.0 kgf·m, 7.4 lb·ft)	
Balancer weight plate screw	M6	2	10 N·m (1.0 kgf·m, 7.4 lb·ft)	
Balancer weight gear nut	M14	1	50 N·m (5.0 kgf·m, 37 lb·ft)	
Balancer nut	M10	1	38 N·m (3.8 kgf·m, 28 lb·ft)	
Timing chain guide stopper plate (exhaust side)	M6	1	10 N·m (1.0 kgf·m, 7.4 lb·ft)	
Timing chain tensioner cap bolt	M6	1	6 N·m (0.6 kgf·m, 4.4 lb·ft)	
Timing chain tensioner bolt	M6	2	10 N·m (1.0 kgf·m, 7.4 lb·ft)	
Coolant drain bolt	M6	1	10 N·m (1.0 kgf·m, 7.4 lb·ft)	
Radiator hose clamp screw	M6	8	1.5 N·m (0.15 kgf·m, 1.1 lb·ft)	
Radiator bolt	M6	4	10 N·m (1.0 kgf·m, 7.4 lb·ft)	
Radiator pipe joint bolt	M6	1	10 N·m (1.0 kgf·m, 7.4 lb·ft)	
Water pump housing cover bolt	M6	4	10 N·m (1.0 kgf·m, 7.4 lb·ft)	
Water pump impeller	M8	1	14 N·m (1.4 kgf·m, 10 lb·ft)	
Oil pump assembly bolt	M5	2	5 N·m (0.5 kgf·m, 3.7 lb·ft)	
Oil pump cover bolt	M4	1	6 N·m (0.6 kgf·m, 4.4 lb·ft)	
Oil strainer bolt	M6	1	10 N·m (1.0 kgf·m, 7.4 lb·ft)	
Throttle cable cover bolt	M5	1	3.5 N·m (0.35 kgf·m, 2.6 lb·ft)	
Throttle body joint bolt	M6	2	10 N·m (1.0 kgf·m, 7.4 lb·ft)	
Throttle body joint clamp screw	M5	1	3.0 N·m (0.30 kgf·m, 2.2 lb·ft)	
Air filter case joint clamp screw	M5	1	3.0 N·m (0.30 kgf·m, 2.2 lb·ft)	
Air filter case bolt	M6	3	7 N·m (0.7 kgf·m, 5.2 lb·ft)	
Air filter case bracket bolt	M6	4	7 N·m (0.7 kgf·m, 5.2 lb·ft)	

TIGHTENING TORQUES

Item	Thread size	Q'ty	Tightening torques	Remarks
Intake air temperature sensor screw	M5	1	1.5 N·m (0.15 kgf·m, 1.1 lb·ft)	
Clutch cable locknut (clutch cable adjuster)	M6	1	4.3 N·m (0.43 kgf·m, 3.2 lb·ft)	
Clutch cable locknut (engine side)	M8	1	7 N·m (0.7 kgf·m, 5.2 lb·ft)	
Exhaust pipe nut	M6	2	10 N·m (1.0 kgf·m, 7.4 lb·ft)	
Exhaust pipe protector screw	M6	2	10 N·m (1.0 kgf·m, 7.4 lb·ft)	
Exhaust pipe bracket bolt	M8	1	20 N·m (2.0 kgf·m, 15 lb·ft)	
Silencer bolt (front)	M8	1	30 N·m (3.0 kgf·m, 22 lb·ft)	
Silencer bolt (rear)	M8	1	30 N·m (3.0 kgf·m, 22 lb·ft)	
Exhaust pipe clamp bolt	M8	2	12 N·m (1.2 kgf·m, 8.9 lb·ft)	
Silencer body bolt	M5	6	8 N·m (0.8 kgf·m, 5.9 lb·ft)	
Oil nozzle bolt	M5	1	5 N·m (0.5 kgf·m, 3.7 lb·ft)	
Engine oil drain bolt	M10	1	20 N·m (2.0 kgf·m, 15 lb·ft)	
Crankcase bolt	M6	13	12 N·m (1.2 kgf·m, 8.9 lb·ft)	
Clutch cable holder bolt	M6	2	10 N·m (1.0 kgf·m, 7.4 lb·ft)	
Crankshaft end accessing screw	M36	1	10 N·m (1.0 kgf·m, 7.4 lb·ft)	
Timing mark accessing screw	M14	1	6 N·m (0.6 kgf·m, 4.4 lb·ft)	
Drive sprocket cover bolt	M6	2	7 N·m (0.7 kgf·m, 5.2 lb·ft)	
Crankcase bearing cover plate screw	M8	4	22 N·m (2.2 kgf·m, 16 lb·ft)	
Bearing plate cover bolt (left side of the drive axle)	M6	2	12 N·m (1.2 kgf·m, 8.9 lb·ft)	
Plate bolt	M6	4	12 N·m (1.2 kgf·m, 8.9 lb·ft)	
Clutch cover bolt	M6	6	10 N·m (1.0 kgf·m, 7.4 lb·ft)	
Crankcase cover bolt (left)	M6	7	10 N·m (1.0 kgf·m, 7.4 lb·ft)	
Crankcase cover bolt (right)	M6	9	10 N·m (1.0 kgf·m, 7.4 lb·ft)	
Oil filter element cover bolt	M6	2	10 N·m (1.0 kgf·m, 7.4 lb·ft)	
Starter clutch screw	M6	8	12 N·m (1.2 kgf·m, 8.9 lb·ft)	
Primary drive gear nut	M16	1	105 N·m (10.5 kgf·m, 77 lb·ft)	
Clutch spring bolt	M6	6	10 N·m (1.0 kgf·m, 7.4 lb·ft)	
Clutch boss nut	M20	1	95 N·m (9.5 kgf·m, 70 lb·ft)	Stake. 
Drive sprocket nut	M18	1	75 N·m (7.5 kgf·m, 55 lb·ft)	Use a lock washer.
Segment bolt	M8	1	30 N·m (3.0 kgf·m, 22 lb·ft)	
Shift guide bolt	M6	2	10 N·m (1.0 kgf·m, 7.4 lb·ft)	
Stopper lever bolt	M6	1	10 N·m (1.0 kgf·m, 7.4 lb·ft)	

TIGHTENING TORQUES

Item	Thread size	Q'ty	Tightening torques	Remarks
Shift pedal bolt	M6	1	12 N·m (1.2 kgf·m, 8.9 lb·ft)	△
Generator rotor nut	M12	1	65 N·m (6.5 kgf·m, 48 lb·ft)	
Stator coil screw	M5	3	10 N·m (1.0 kgf·m, 7.4 lb·ft)	
Crankshaft position sensor bolt	M6	2	10 N·m (1.0 kgf·m, 7.4 lb·ft)	
Stator coil assembly lead holder bolt	M5	1	8 N·m (0.8 kgf·m, 5.9 lb·ft)	
Coolant temperature sensor	M10	1	15 N·m (1.5 kgf·m, 11 lb·ft)	
Gear position switch bolt	M5	2	3.5 N·m (0.35 kgf·m, 2.6 lb·ft)	
Rectifier/regulator bolt	M6	2	7 N·m (0.7 kgf·m, 5.2 lb·ft)	
Ignition coil bolt	M6	2	7 N·m (0.7 kgf·m, 5.2 lb·ft)	
Starter motor bolt	M6	2	10 N·m (1.0 kgf·m, 7.4 lb·ft)	
Nut (holder)	M6	1	8 N·m (0.8 kgf·m, 5.9 lb·ft)	
Throttle position sensor screw	M5	1	3.5 N·m (0.35 kgf·m, 2.6 lb·ft)	
Intake air pressure sensor screw	M6	1	3.5 N·m (0.35 kgf·m, 2.6 lb·ft)	

TIP

Cylinder head bolt

Tighten all the cylinder head tightening bolts evenly in the tightening order to 30 N·m (3.0 kgf·m, 22 lb·ft). Remove the one bolt according to the tightening order. When doing so, do not remove the other bolts. Retighten the bolt to 15 N·m (1.5 kgf·m, 11 lb·ft), and then tighten it further to reach the specified angle (60°). Remove the remaining bolts one by one in the same manner and retighten them. Finally, tighten all the bolts to reach the specified angle (60°). Total tightening angle: 60° + 60° = 120° (The first and second time, be sure to apply molybdenum disulfide oil to the bolt threads and seats as well as to both sides of the lock washers.)

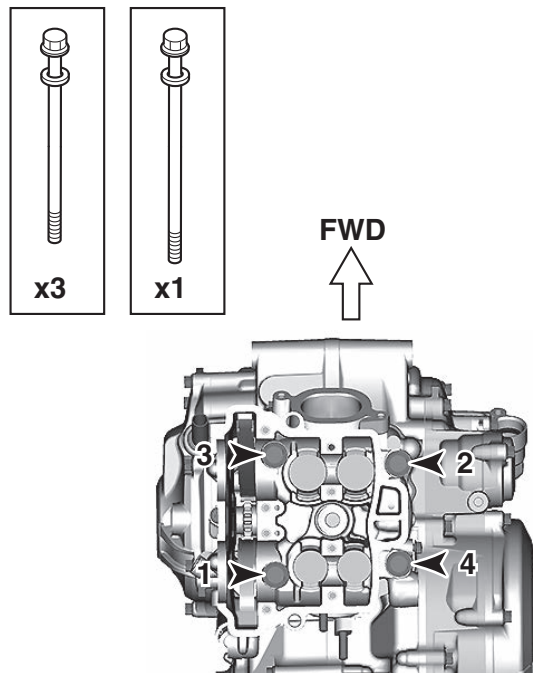

TIGHTENING TORQUES

EAM30204



CHASSIS TIGHTENING TORQUES

TIP

△ - marked portion shall be checked for torque tightening after break-in or before each race.

Item	Thread size	Q'ty	Tightening torques	Remarks
Upper bracket pinch bolt	M8	4	21 N·m (2.1 kgf·m, 15 lb·ft)	△
Lower bracket pinch bolt	M8	4	21 N·m (2.1 kgf·m, 15 lb·ft)	△
Steering stem nut	M24	1	145 N·m (14.5 kgf·m, 107 lb·ft)	△
Upper handlebar holder bolt	M8	4	28 N·m (2.8 kgf·m, 21 lb·ft)	△
Lower handlebar holder nut	M10	2	40 N·m (4.0 kgf·m, 30 lb·ft)	△
Handlebar switch screw (left)	M4	1	1.3 N·m (0.13 kgf·m, 0.95 lb·ft)	
Start switch	M3	1	0.5 N·m (0.05 kgf·m, 0.37 lb·ft)	
Lower ring nut	M28	1	See TIP.	△
Damper assembly (front fork)	M51	2	30 N·m (3.0 kgf·m, 22 lb·ft)	
Inner tube and adjuster	M22	2	55 N·m (5.5 kgf·m, 41 lb·ft)	
Base valve (front fork)	M42	2	28 N·m (2.8 kgf·m, 21 lb·ft)	
Adjuster (damper assembly)	M12	2	29 N·m (2.9 kgf·m, 21 lb·ft)	
Bleed screw (front fork)	M5	2	1.3 N·m (0.13 kgf·m, 0.95 lb·ft)	
Screw (adjuster knob)	M4	2	0.6 N·m (0.06 kgf·m, 0.44 lb·ft)	
Front fork protector bolt	M6	6	7 N·m (0.7 kgf·m, 5.2 lb·ft)	△
Brake hose holder bolt	M6	2	9 N·m (0.9 kgf·m, 6.6 lb·ft)	△
Screw (throttle cable housing)	M5	2	3.8 N·m (0.38 kgf·m, 2.8 lb·ft)	
Clutch lever holder bolt	M6	2	5 N·m (0.5 kgf·m, 3.7 lb·ft)	
Clutch lever pivot bolt	M6	1	3.0 N·m (0.30 kgf·m, 2.2 lb·ft)	
Clutch lever pivot nut	M6	1	7 N·m (0.7 kgf·m, 5.2 lb·ft)	
Clutch lever position locknut	M5	1	4.8 N·m (0.48 kgf·m, 3.5 lb·ft)	
Front brake master cylinder holder bolt	M6	2	9 N·m (0.9 kgf·m, 6.6 lb·ft)	△
Front brake master cylinder reservoir cap screw	M4	2	1.5 N·m (0.15 kgf·m, 1.1 lb·ft)	
Front brake lever pivot bolt	M6	1	6 N·m (0.6 kgf·m, 4.4 lb·ft)	
Front brake lever pivot nut	M6	1	6 N·m (0.6 kgf·m, 4.4 lb·ft)	
Locknut (front brake lever position)	M6	1	5 N·m (0.5 kgf·m, 3.7 lb·ft)	
Front brake hose union bolt	M10	2	30 N·m (3.0 kgf·m, 22 lb·ft)	△
Front brake caliper bolt	M8	2	28 N·m (2.8 kgf·m, 21 lb·ft)	△
Front brake pad pin	M10	1	17 N·m (1.7 kgf·m, 13 lb·ft)	
Front brake pad pin plug	M10	1	2.5 N·m (0.25 kgf·m, 1.8 lb·ft)	
Front brake caliper bleed screw	M8	1	5 N·m (0.5 kgf·m, 3.7 lb·ft)	△
Front wheel axle nut	M18	1	115 N·m (11.5 kgf·m, 85 lb·ft)	△

TIGHTENING TORQUES

Item	Thread size	Q'ty	Tightening torques	Remarks
Front wheel axle pinch bolt	M8	4	21 N·m (2.1 kgf·m, 15 lb·ft)	△
Front brake disc bolt	M6	6	12 N·m (1.2 kgf·m, 8.9 lb·ft)	△/- 
Rear brake disc bolt	M6	6	12 N·m (1.2 kgf·m, 8.9 lb·ft)	△/- 
Footrest bracket bolt	M10	4	55 N·m (5.5 kgf·m, 41 lb·ft)	- 
Rear brake pedal bolt	M8	1	26 N·m (2.6 kgf·m, 19 lb·ft)	△
Rear brake pedal adjusting locknut	M6	1	6 N·m (0.6 kgf·m, 4.4 lb·ft)	
Rear brake master cylinder bolt	M6	2	10 N·m (1.0 kgf·m, 7.4 lb·ft)	△
Rear brake master cylinder reservoir cap bolt	M4	2	1.5 N·m (0.15 kgf·m, 1.1 lb·ft)	
Rear brake hose union bolt	M10	2	30 N·m (3.0 kgf·m, 22 lb·ft)	△
Rear brake caliper bleed screw	M8	1	5 N·m (0.5 kgf·m, 3.7 lb·ft)	△
Rear brake pad pin	M10	1	17 N·m (1.7 kgf·m, 13 lb·ft)	
Rear brake pad pin plug	M10	1	2.5 N·m (0.25 kgf·m, 1.8 lb·ft)	
Rear wheel axle nut	M22	1	135 N·m (13.5 kgf·m, 100 lb·ft)	△
Drive chain puller locknut	M8	2	21 N·m (2.1 kgf·m, 15 lb·ft)	
Rear wheel sprocket nut	M8	6	42 N·m (4.2 kgf·m, 31 lb·ft)	△
Nipple (spoke)	—	72	2.5 N·m (0.25 kgf·m, 1.8 lb·ft)	△
Rear brake caliper protector bolt	M6	2	7 N·m (0.7 kgf·m, 5.2 lb·ft)	△
Engine mounting bolt (upper side)	M10	2	45 N·m (4.5 kgf·m, 33 lb·ft)	△
Engine mounting bolt (front side)	M10	1	55 N·m (5.5 kgf·m, 41 lb·ft)	△
Engine mounting bolt (lower side)	M10	1	53 N·m (5.3 kgf·m, 39 lb·ft)	△
Engine bracket bolt (upper side)	M8	4	34 N·m (3.4 kgf·m, 25 lb·ft)	△
Engine bracket bolt (front side)	M8	2	34 N·m (3.4 kgf·m, 25 lb·ft)	△
Rear frame bolt	M8	4	38 N·m (3.8 kgf·m, 28 lb·ft)	△
Engine guard bolt (right side)	M6	1	7 N·m (0.7 kgf·m, 5.2 lb·ft)	△
Pivot shaft nut	M16	1	85 N·m (8.5 kgf·m, 63 lb·ft)	△
Rear shock absorber assembly upper nut	M10	1	56 N·m (5.6 kgf·m, 41 lb·ft)	△
Rear shock absorber assembly lower nut	M10	1	53 N·m (5.3 kgf·m, 39 lb·ft)	△
Relay arm nut (swingarm side)	M14	1	70 N·m (7.0 kgf·m, 52 lb·ft)	△
Connecting arm nut (relay arm side)	M14	1	80 N·m (8.0 kgf·m, 59 lb·ft)	△
Connecting arm nut (frame side)	M14	1	80 N·m (8.0 kgf·m, 59 lb·ft)	△
Brake hose holder screw	M5	4	3.5 N·m (0.35 kgf·m, 2.6 lb·ft)	△
Drive chain tensioner bolt (upper side)	M8	1	16 N·m (1.6 kgf·m, 12 lb·ft)	
Drive chain tensioner bolt (lower side)	M8	1	16 N·m (1.6 kgf·m, 12 lb·ft)	

TIGHTENING TORQUES

Item	Thread size	Q'ty	Tightening torques	Remarks
Bolt (drive chain support)	M6	1	7 N·m (0.7 kgf·m, 5.2 lb·ft)	
Drive chain support nut	M6	2	7 N·m (0.7 kgf·m, 5.2 lb·ft)	
Drive chain guide bolt	M5	3	4.0 N·m (0.40 kgf·m, 3.0 lb·ft)	
Fuel tank bolt (front side)	M6	2	8 N·m (0.8 kgf·m, 5.9 lb·ft)	△
Screw (fuel tank)	M6	1	4.0 N·m (0.40 kgf·m, 3.0 lb·ft)	
Fuel pump bolt	M5	5	7 N·m (0.7 kgf·m, 5.2 lb·ft)	△
Screw (fuel inlet pipe)	M5	2	3.5 N·m (0.35 kgf·m, 2.6 lb·ft)	
Seat set bracket screw	M6	1	7 N·m (0.7 kgf·m, 5.2 lb·ft)	
Seat bolt	M6	2	13 N·m (1.3 kgf·m, 9.6 lb·ft)	△
Side cover bolt (left)	M6	2	7 N·m (0.7 kgf·m, 5.2 lb·ft)	△
Side cover bolt (right)	M6	2	7 N·m (0.7 kgf·m, 5.2 lb·ft)	△
Shroud bolt (frame)	M6	2	7 N·m (0.7 kgf·m, 5.2 lb·ft)	△
Shroud bolt (air filter case)	M6	2	7 N·m (0.7 kgf·m, 5.2 lb·ft)	△
Shroud bolt (fuel tank)	M6	2	7 N·m (0.7 kgf·m, 5.2 lb·ft)	△
Shroud bolt (radiator guard)	M6	2	7 N·m (0.7 kgf·m, 5.2 lb·ft)	△
Front fender bolt	M6	4	10 N·m (1.0 kgf·m, 7.4 lb·ft)	△
Rear fender bolt (front side)	M6	4	7 N·m (0.7 kgf·m, 5.2 lb·ft)	△
Rear fender bolt (rear side)	M6	2	16 N·m (1.6 kgf·m, 12 lb·ft)	△
Screw (mud flap)	—	2	1.3 N·m (0.13 kgf·m, 0.95 lb·ft)	△
Number plate bolt	M6	1	7 N·m (0.7 kgf·m, 5.2 lb·ft)	△
Frame ground bolt (negative battery lead)	M6	1	7 N·m (0.7 kgf·m, 5.2 lb·ft)	
Ignition coil bracket bolt	M6	2	7 N·m (0.7 kgf·m, 5.2 lb·ft)	
Starter relay bolt	M6	2	3.5 N·m (0.35 kgf·m, 2.6 lb·ft)	
Battery box bolt	M6	2	7 N·m (0.7 kgf·m, 5.2 lb·ft)	

TIP

Lower ring nut

1. First, tighten the lower ring nut approximately 38 N·m (3.8 kgf·m, 28 lb·ft) by using the steering nut wrench, then loosen the lower ring nut one turn.
2. Retighten the lower ring nut 7 N·m (0.7 kgf·m, 5.2 lb·ft).

TIGHTENING TORQUES

PERIODIC CHECKS AND ADJUSTMENTS

SERVICING PARTS	3-1
MAINTENANCE INTERVALS	3-2
MAINTENANCE INTERVALS.....	3-2
PRE-OPERATION INSPECTION AND MAINTENANCE	3-6
GENERAL INSPECTION AND MAINTENANCE.....	3-6
ENGINE	3-7
ADJUSTING THE VALVE CLEARANCE.....	3-7
CHECKING THE ENGINE IDLING SPEED.....	3-8
CHECKING THE THROTTLE GRIP	3-8
CHECKING THE SPARK PLUG.....	3-9
CHECKING THE ENGINE OIL LEVEL.....	3-9
CHANGING THE ENGINE OIL.....	3-10
ADJUSTING THE CLUTCH LEVER FREE PLAY	3-11
ADJUSTING THE CLUTCH LEVER POSITION.....	3-12
CLEANING THE AIR FILTER ELEMENT	3-12
CHECKING THE THROTTLE BODY JOINT.....	3-14
CHECKING THE FUEL LINE	3-15
CHECKING THE CYLINDER HEAD BREATHER HOSE	3-15
CHECKING THE EXHAUST SYSTEM	3-15
CHECKING THE COOLANT LEVEL	3-17
CHECKING THE COOLING SYSTEM	3-18
CHANGING THE COOLANT.....	3-18
CHASSIS	3-20
ADJUSTING THE FRONT DISC BRAKE.....	3-20
ADJUSTING THE REAR DISC BRAKE	3-20
CHECKING THE BRAKE FLUID LEVEL.....	3-20
CHECKING THE FRONT BRAKE PADS.....	3-21
CHECKING THE REAR BRAKE PADS	3-21
CHECKING THE FRONT BRAKE HOSE	3-21
CHECKING THE REAR BRAKE HOSE	3-22
CHECKING THE BRAKE OPERATION.....	3-22
BLEEDING THE HYDRAULIC BRAKE SYSTEM	3-22
DRIVE CHAIN SLACK.....	3-23
CHECKING AND ADJUSTING THE STEERING HEAD	3-24
LUBRICATING THE STEERING HEAD.....	3-25
CHECKING THE FRONT FORK LEGS	3-25
ADJUSTING THE FRONT FORK LEGS	3-26
CHECKING THE REAR SHOCK ABSORBER ASSEMBLY	3-27
ADJUSTING THE REAR SHOCK ABSORBER ASSEMBLY	3-27
CHECKING THE SWINGARM OPERATION.....	3-29
LUBRICATING THE SWINGARM PIVOT	3-29
CHECKING THE TIRES	3-30
CHECKING AND TIGHTENING THE SPOKES.....	3-30
CHECKING THE WHEELS	3-30

CHECKING THE CHASSIS FASTENERS	3-31
CHECKING AND LUBRICATING THE CABLES	3-31
LUBRICATING THE BRAKE LEVER	3-31
LUBRICATING THE CLUTCH LEVER.....	3-31
LUBRICATING THE PEDAL.....	3-31
ELECTRICAL SYSTEM	3-32
CHECKING AND CHARGING THE BATTERY	3-32
CHECKING THE FUSES.....	3-32

EAM20202

SERVICING PARTS

Regularly check or replace the servicing parts shown in the illustration.

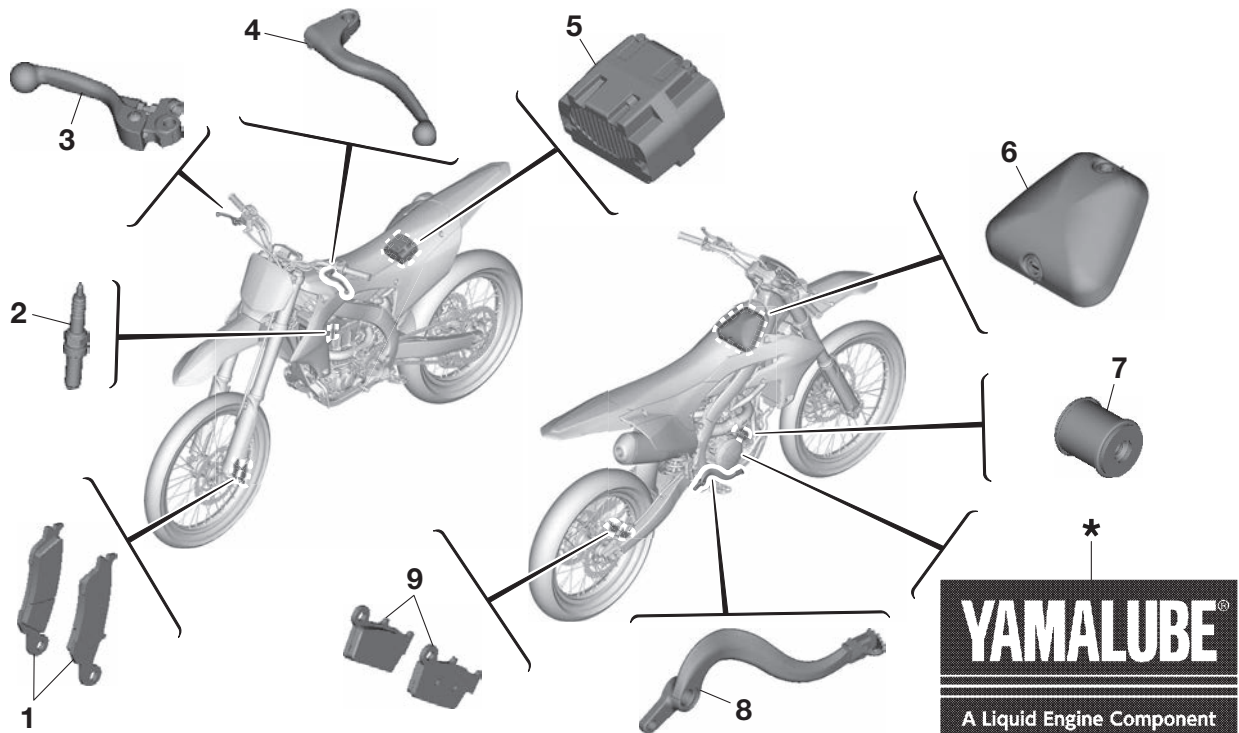

* Engine oil, lubricants & greases, care products.

Ref. No.	Part No.	Part name in parts catalog	Q'ty
1	B2W-25805-00	BRAKE PAD KIT	1
2	94701-00424	PLUG, SPARK (NGK LMAR9E-J)	1
3	B2W-83922-00	LEVER 2	1
4	17D-83912-01	LEVER 1	1
5	BR9-82100-58 *	BATTERY ASSY (BR98)	1
	BR9-82100-78 **		
6	BHR-14451-00	ELEMENT, AIR CLEANER	1
7	5D3-13440-02	ELEMENT ASSY, OIL CLEANER	1
8	BHR-27200-00	PEDAL, BRAKE	1
9	1C3-W0046-50	BRAKE PAD KIT 2	1

* For AUS, AUT, BEL, CHE, CYP, CZE, DEU, DNK, ESP, FIN, FRA, GBR, GRC, HRV, HUN, IRL, ITA, NLD, NOR, NZL, POL, PRT, SVK, SVN, SWE, TUR, ZAF

** For CAN

TIP

The part number is subject to change. In that case, order the part from a Yamaha dealer by stating the identification number of your vehicle.

MAINTENANCE INTERVALS

EAM20157

MAINTENANCE INTERVALS

EAM30369

MAINTENANCE INTERVALS

ECA25871

NOTICE

- After a break-in or before each race, always check the points shown in “TORQUE-CHECK POINTS” for tightening torques and retighten them.
- Periodic inspection is essential in making full use of the machine performance. The life of parts varies significantly according to the environment in which the machine runs (e.g., rain, dirt, etc.). Therefore, earlier inspection is required by reference to the list below.

TIP

Items marked with an asterisk should be performed by a Yamaha dealer as they require special tools, data and technical skills.

No.	Item	Routine	After break-in	Every race (about 2.5 hours)	Every third race (about 7.5 hours)	Every fifth race (about 12.5 hours)	As required
1	* Valve	• Check the valve clearances.	√		√		
		• Check the valve seats and the valve faces for wear.				√	
		• Replace.					√
2	* Valve spring	• Check the free length.				√	
		• Replace.					√
3	* Valve lifter	• Check for scratches and wear.				√	
		• Replace.					√
4	* Camshaft	• Inspect the camshaft surface. • Inspect the decompression system.				√	
		• Replace.					√
5	* Timing chain	• Check for damage and sticking.					√
		• Replace the timing chain and timing chain tensioner as a set.				√	√
6	* Timing chain tensioner	• Replace the timing chain and timing chain tensioner as a set.				√	√
7	* Camshaft sprocket	• Check for wear on the teeth and for damage.				√	
		• Replace.					√
8	* Piston	• Inspect crack.					√
		• Inspect carbon deposits and eliminate them.					√
		• Replace the piston, piston pin, piston pin clip, and piston ring all as a set.				√	√
9	* Piston ring	• Check the end gap of the piston ring.					√
		• Replace the piston, piston pin, piston pin clip, and piston ring all as a set.				√	√
10	* Piston pin	• Inspect.					√
		• Replace the piston, piston pin, piston pin clip, and piston ring all as a set.				√	√

MAINTENANCE INTERVALS

No.	Item	Routine	After break-in	Every race (about 2.5 hours)	Every third race (about 7.5 hours)	Every fifth race (about 12.5 hours)	As required	
11 *	Cylinder head	<ul style="list-style-type: none"> Check the coolant passages for corrosion. Inspect carbon deposits and eliminate them. Check for warpage, and replace the gasket. 				√		
12 *	Cylinder	Inspect score marks.				√		
		Inspect wear.					√	
13	Engine oil	Check the engine oil amount.		√			√	
		Replace.	√		√			
14	Oil filter element	Replace.	√			√	√	
15 *	Oil strainer	Clean.				√		
16 *	Clutch	Inspect housing, friction plate, clutch plate and spring.	√	√				
		Replace.					√	
17 *	Transmission	Inspect.					√	
		Replace bearings.					√	
18 *	Shift fork, shift drum, guide bar	Inspect wear.					√	
19 *	Nut (generator rotor)	Check for tightening torques.	√			√		
20 *	Exhaust pipe, silencer, protector	Check for exhaust leaks, and tightening torques.	√	√				
		Clean.				√		
		Replace filter. (When the exhaust sound becomes louder or when a performance drop is felt.)			√		√	
21 *	Crankshaft	Inspect and clean.				√	√	
22 *	Throttle body	Inspect.					√	
23	Air filter	Clean and lubricate.	√	√				
		Replace.					√	
24	Spark plug	Check the electrodes and the terminals for wear.	√		√			
		Replace.					√	
25 *	Cooling system	Check coolant level and leakage.	√	√				
		Check radiator cap operation.					√	
		Check radiator cap attached.	√	√				
		Change the coolant.	Every two years					√
		Inspect hoses.		√				
26 *	Engine guard	Replace.					√	
27 *	Frame	Clean and inspect.	√	√				
28 *	Fuel tank, fuel pump	Inspect.	√		√			
29 *	Fuel hose	Inspect.					√	
		Replace.	Every four years				√	

MAINTENANCE INTERVALS

No.	Item	Routine	After break-in	Every race (about 2.5 hours)	Every third race (about 7.5 hours)	Every fifth race (about 12.5 hours)	As required
30	* Front fork leg(s)	• Clean.	√	√			
		• Inspect and adjust.	√	√			
		• Replace oil.	√			√	
		• Replace oil seal.					√
		• Clean and grease oil seals and dust seals.	√	√			√
31	Protector guide	• Replace.					√
32	* Rear shock absorber	• Inspect and adjust.	√	√			
		• Grease pillow balls and bearings. (After rain ride)			√		√
		• Check for tightening torques.	√	√			
33	* Brake(s)	• Adjust lever position and pedal position.	√	√			
		• Lubricate pivot point.	√	√			
		• Check brake disc surface.	√	√			
		• Check fluid level and leakage.	√	√			
		• Retighten brake disc bolts, caliper bolts, master cylinder bolts and union bolts. (Check for tightening torques.)	√	√			
		• Replace pads.					√
		• Replace brake fluid.		Every one year			
34	* Swingarm	• Inspect, lube and retighten.	√	√			
35	* Relay arm, connecting rod	• Inspect, lube and retighten.	√	√			
36	* Steering head	• Inspect free play and retighten. (Check for tightening torques.)	√	√			
		• Clean and lube. (After rain ride)				√	
		• Replace bearings.					√
37	* Tire, wheels	• Inspect air pressure, wheel run-out, tire wear and spoke looseness.	√	√			
		• Retighten sprocket bolt.	√	√			
		• Check the bearing.			√		
		• Replace bearings.					√
		• Lubricate.			√		
38	* Drive chain	• Clean, lubricate, slack, alignment.	√	√			
		• Replace.					√
39	* Drive chain guide	• Inspect wear.		√			
40	* Drive chain guide and drive chain support	• Replace.					√
41	Cables	• Routing (Connection)	√	√			
		• Check and grease.	√	√			
		• Check throttle cables on the throttle body for dirt and wear.	√	√			
42	Levers	• Adjust clutch lever free play.					√

MAINTENANCE INTERVALS

No.	Item	Routine	After break-in	Every race (about 2.5 hours)	Every third race (about 7.5 hours)	Every fifth race (about 12.5 hours)	As required
43	Brake pedal, footrest	• Lubricate.	√	√			
44 *	Outside nuts and bolts	• Retighten.	√	√			
45 *	Battery	• Check terminal for looseness and corrosion.					√

PRE-OPERATION INSPECTION AND MAINTENANCE

EAM20134

PRE-OPERATION INSPECTION AND MAINTENANCE

Before riding for break-in operation, practice or a race, make sure the machine is in good operating condition.

Before using this machine, check the following points.

EAM30209

GENERAL INSPECTION AND MAINTENANCE

Item	Inspect	Page
Coolant	Check that coolant is filled up to the radiator cap. Check the cooling system for leakage.	3-17, 3-18, 3-18
Fuel	Check that a fresh gasoline is filled in the fuel tank. Check the fuel line for leakage.	1-18
Engine oil	Check that the oil level is correct. Check the crankcase and oil line for leakage.	3-9, 3-10
Gear shifter and clutch	Check that gears can be shifted correctly in order and that the clutch operates smoothly.	3-11, 3-12
Throttle grip/Housing	Check that the throttle grip operation and free play are correctly adjusted. Lubricate the throttle grip and housing, if necessary.	3-8, 3-31
Brakes	Check the play of front brake and effect of front and rear brake.	3-20, 3-20, 3-20, 3-21, 3-21, 3-21, 3-22, 3-22
Drive chain	Check drive chain slack and alignment. Check that the drive chain is lubricated properly.	3-23, 4-30, 4-30, 4-31, 4-31, 4-31
Wheels	Check for excessive wear and tire pressure. Check for loose spokes and have no excessive play.	3-30, 3-30, 3-30
Steering	Check that the handlebar can be turned smoothly and have no excessive play.	3-24
Front forks and rear shock absorber	Check that they operate smoothly and there is no oil leakage.	3-25, 3-26, 3-27, 3-27, 3-29
Cables (wires)	Check that the clutch and throttle cables move smoothly. Check that they are not caught when the handlebars are turned or when the front forks travel up and down.	—
Exhaust pipe	Check that the exhaust pipe is tightly mounted and has no cracks.	3-15
Rear wheel sprocket	Check that the rear wheel sprocket tightening bolt is not loose.	4-4, 4-4, 4-4
Lubrication	Check for smooth operation. Lubricate if necessary.	3-31, 3-31, 3-31, 3-31
Bolts and nuts	Check the chassis and engine for loose bolts and nuts.	1-21
Lead connectors	Check that the stator coil assembly, ECU and ignition coil are connected tightly.	—
Settings	Is the machine set suitably for the condition of the racing course and weather or by taking into account the results of test runs before racing? Are inspection and maintenance completely done?	9-1, 9-1, 9-1, 9-2, 9-2, 9-3, 9-3, 9-4, 9-4, 9-5, 9-6

TIP

Perform usual maintenance enough so that, in the race course, a confirmation of that and simple setting adjustments may only be left, in order to get enough time to use effectively.

EAM20135

ENGINE

EAM30226

ADJUSTING THE VALVE CLEARANCE

TIP

- This section is intended for those who have basic knowledge and skill concerning the servicing of Yamaha motorcycles (e.g., Yamaha dealers, service engineers, etc.). Those who have little knowledge and skill concerning servicing are requested not to undertake inspection, adjustment, disassembly, or reassembly only by reference to this manual. It may lead to servicing trouble and mechanical damage.
- Make sure that the valve clearance is checked or adjusted while the engine is cold (at room temperature).
- While the valve clearance is checked or adjusted, make sure that the piston is positioned in the top dead center (TDC).

1. Remove:

- Seat
- Side cover (left/right)
- Shroud (left/right)
- Fuel tank

Refer to "FUEL TANK" on page 6-1.

2. Remove:

- Spark plug
- Cylinder head cover

3. Remove:

- Timing mark accessing screw "1"
- Crankshaft end accessing screw "2"
- O-ring

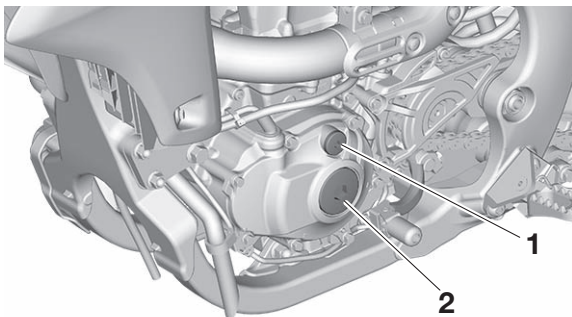

4. Check:

- Valve clearance
Out of specification → Regulate.



Valve clearance (cold)

Intake

0.12–0.19 mm (0.0047–0.0075 in)

Exhaust

0.17–0.24 mm (0.0067–0.0094 in)

- Turn the crankshaft counterclockwise with a wrench.
- Align the top dead center (TDC) mark "a" on the generator rotor with the alignment mark "b" on the crankcase cover.

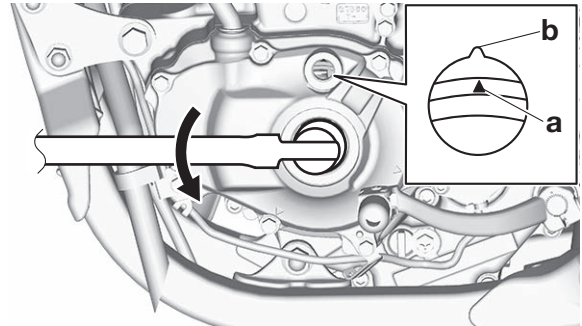

TIP

Check that the alignment mark "c" on the camshaft sprocket and the alignment mark "d" on the intake camshaft sprocket are aligned with the edge of the cylinder head.

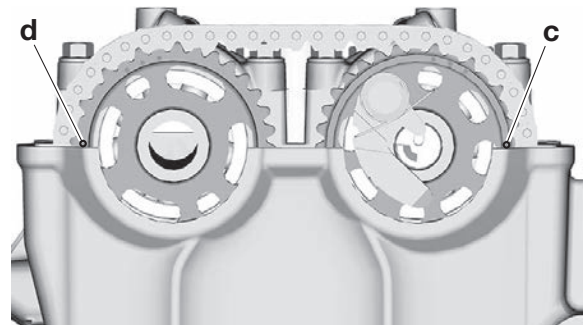

- Measure the valve clearance using a thickness gauge "1".



Thickness gauge

90890-03268

Feeler gauge set

YU-26900-9

TIP

Record the measured reading if the clearance is incorrect.

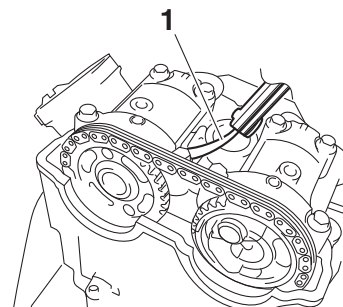

EAM30412

CHECKING THE ENGINE IDLING SPEED

TIP

- Because the air pressure is lower at high altitudes, the air-fuel mixture will become richer. If the idling speed is low, turn the idle screw clockwise to increase the speed before the adjustment.
- Before adjusting the engine idling speed, make sure that the air filter element is not clogged, the engine compression is proper, and the throttle grip free play is proper.
- Adjust the engine idling speed with the starter knob pulled in completely.

1. Start the engine, and warm this up until the oil has reached the specified temperature.
2. Measure the coolant temperature using the Yamaha diagnostic tool.



Yamaha diagnostic tool USB
90890-03274
Yamaha diagnostic tool (A/I)
90890-03273



Coolant temperature
70–80 °C (158–176 °F)

3. Install:
 - Digital tachometer



Digital tachometer
90890-06760
Digital tachometer
YU-39951-B

TIP

Get the high tension cord "1" of the ignition coil pinched in the detector "a" of the digital tachometer.

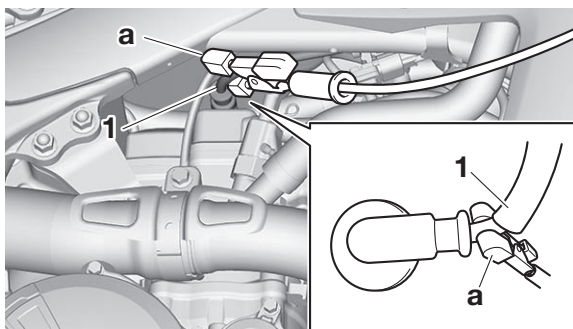

4. Measure:
 - Engine idling speed
Out of specification → Regulate.



Engine idling speed
1900–2100 r/min

5. Adjust:
 - Engine idling speed
 - a. Turn the idle screw "1" to make an adjustment.

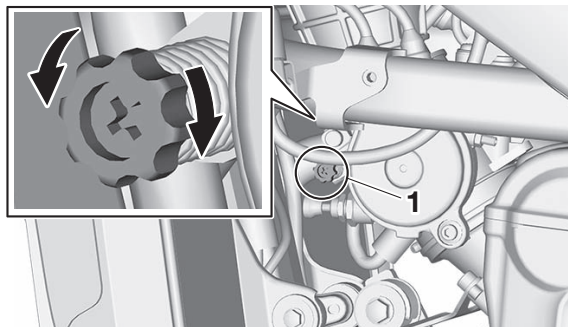

EAM30475

CHECKING THE THROTTLE GRIP

TIP

Prior to adjusting throttle grip free play, the engine idling speed should be adjusted.

1. Check:
 - Throttle grip free play "a"
Out of specification → Regulate.



Throttle grip free play
3.0–6.0 mm (0.12–0.24 in)

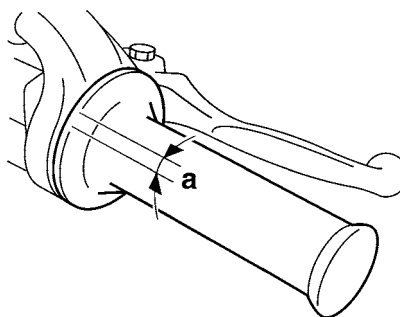

2. Adjust:
 - Throttle grip free play
 - a. Loosen the locknut "1".
 - b. Turn the adjuster "2" until the specified throttle grip free play is obtained.
 - c. Tighten the locknut.

EWA18470

⚠ WARNING

After adjusting the throttle grip free play, start the engine and turn the handlebar to the right and to the left to ensure that this does not cause the engine idling speed to change.

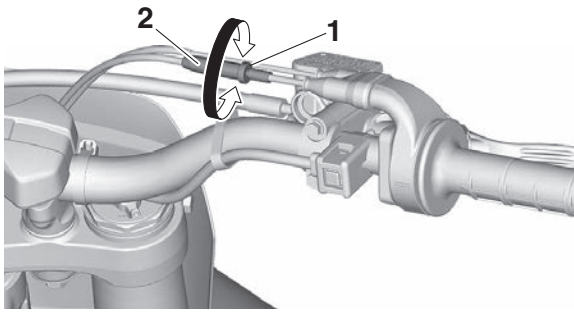

EAM30254

CHECKING THE SPARK PLUG

1. Remove:

- Seat
- Side cover (left/right)
- Shroud (left/right)
- Fuel tank "1"

Refer to "FUEL TANK" on page 6-1.

ECA24400

NOTICE

Do not use too much force to pull the hose.

TIP

Remove the fuel tank, turn this 180° clockwise, and put it in the frame "2" as shown.

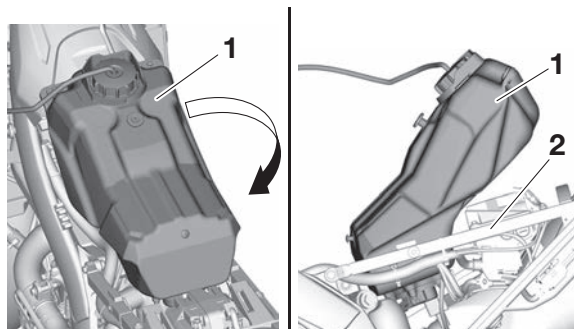

2. Remove:

- Holder
- Spark plug cap
- Spark plug

ECA24410

NOTICE

In order not to allow the dirt accumulated around the spark plug to drop from the spark plug hole into the cylinder, clean it before removing the spark plug.

3. Check:

- Spark plug type
Wrong type → Replace.



Manufacturer/model
NGK/LMAR9E-J

4. Check:

- Electrode "1"
Damage/wear → Replace the spark plug.
- Insulator "2"
Abnormal color → Replace the spark plug.
Normal color is medium-to-light tan.

5. Clean:

- Spark plug
(with a spark plug cleaner or a wire brush)

6. Measure:

- Spark plug gap "a"
Out of specification → Adjust the spark plug gap.



Spark plug gap
0.6–0.7 mm (0.024–0.028 in)

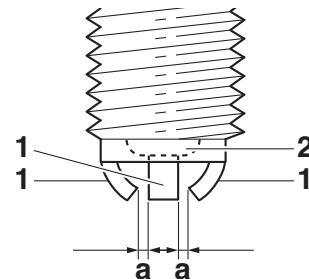

7. Install:

- Spark plug



Spark plug
13 N·m (1.3 kgf·m, 9.6 lb-ft)

TIP

Before installing the spark plug, clean the spark plug and gasket surface.

8. Install:

- Spark plug cap
- Holder
- Fuel tank
- Shroud (left/right)
- Side cover (left/right)
- Seat

Refer to "GENERAL CHASSIS" on page 4-1.

EAM30224

CHECKING THE ENGINE OIL LEVEL

- Stand the vehicle upright on a level surface.
- Start the engine, warm this up for 2–3 minutes, and then stop the engine and wait about 1 minute.
- Check:
 - Oil level
The engine oil level should be between the

minimum level mark “a” and maximum level mark “b”.

Below the minimum level mark → Add the recommended engine oil to the proper level.

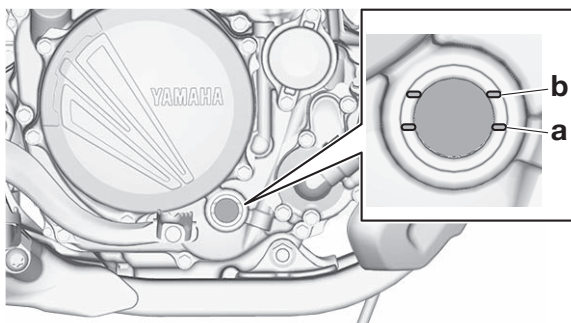

ECA24290

NOTICE

- Since engine oil also lubricates the clutch, the wrong oil types or additives could cause clutch slippage. Therefore, do not add any chemical additives.
- Do not allow foreign material to enter the crankcase.



Recommended brand
YAMALUBE
SAE viscosity grades
10W-40, 10W-50, 15W-40, 20W-40 or 20W-50
Recommended engine oil grade
API service SG type or higher,
JASO standard MA

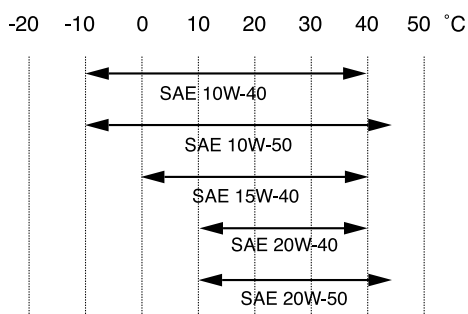

EAM30225

CHANGING THE ENGINE OIL

Stand the vehicle upright on a level surface.

1. Start the engine, warm this up for several minutes, and then stop the engine and wait about 5 minutes.

TIP

This model is equipped with an engine auto-stop system. The engine stops automatically if left idling for 7 minutes. If the engine stops, push the start switch to restart the engine.

2. Place an oil pan under the drain bolt.

3. Remove:

- Oil filler cap “1”
- Drain bolt (with gasket) “2”

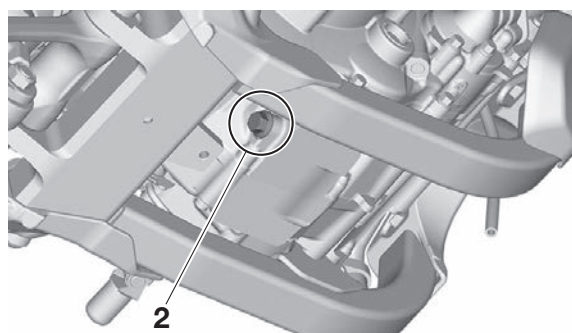
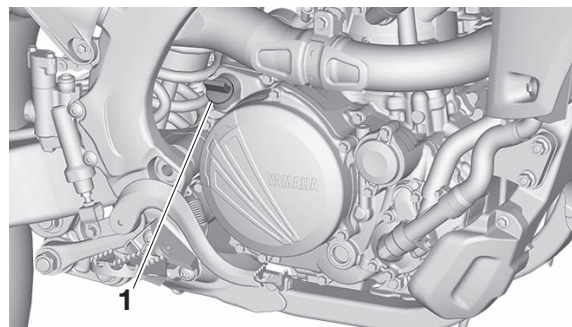

4. If the oil filter element is also to be replaced, perform the following procedure.

- a. Remove the oil filter element cover “1” and oil filter element “2”.
- b. Replace the new O-ring “3”.

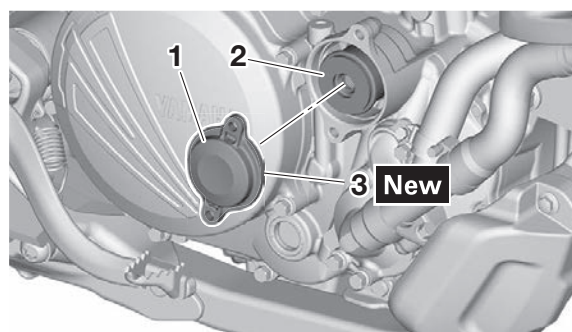

- c. Install the new oil filter element and the oil filter element cover.



Oil filter element cover bolt
10 N·m (1.0 kgf·m, 7.4 lb·ft)

5. To check the oil strainer, perform the following procedure.

- a. Remove the oil strainer “1”.
- b. Check the oil strainer.
 Damage → Replace.
 Clogging due to dirt → Wash with kerosene.

c. Replace the new O-ring "2".

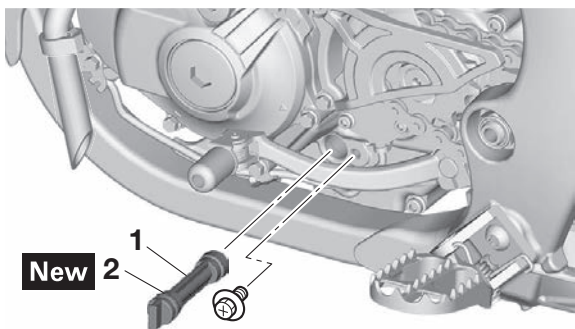

d. Install the oil strainer.

	Oil strainer bolt 10 N·m (1.0 kgf·m, 7.4 lb-ft)
---	---

6. Install:

- Gasket **New**
- Drain bolt

	Drain bolt 20 N·m (2.0 kgf·m, 15 lb-ft)
---	---

7. Pour the specified amount of engine oil into the oil filler cap hole.

	Engine oil quantity Oil change 0.73 L (0.77 US qt, 0.64 Imp.qt) With oil filter removal 0.75 L (0.79 US qt, 0.66 Imp.qt) Quantity (disassembled) 0.95 L (1.00 US qt, 0.84 Imp.qt)
---	--

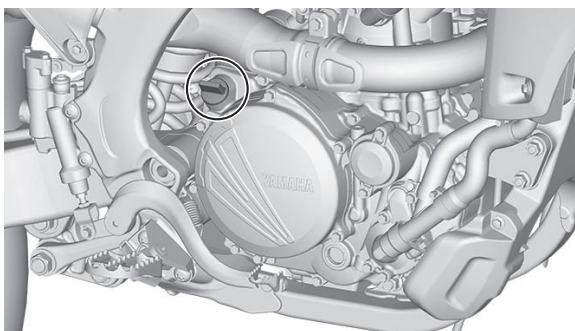

8. Install:

- Oil filler cap

9. Check:

- Oil level

Refer to "CHECKING THE ENGINE OIL LEVEL" on page 3-9.

10. Check:

- Engine oil pressure

a. Slightly loosen the oil pressure check bolt "1".

EWA19120

WARNING

When the engine is started with the check bolt removed, oil will spout; therefore, always loosen it before the checkup.

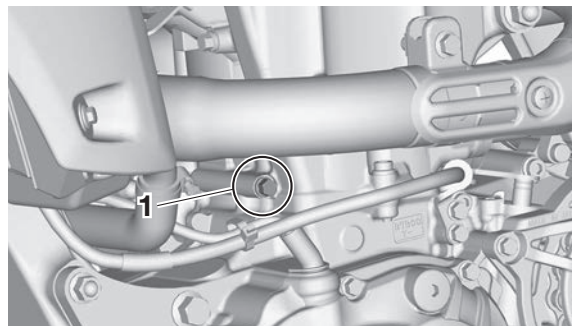

b. Start the engine and keep it idling until oil starts to seep from the oil pressure check bolt.

EWA19130

WARNING

Always keep the engine idling speed during the checkup without increasing the engine speed.

ECA25840

NOTICE

If no engine oil seeps out after one minute, immediately turn the engine off so it will not seize.

- If no engine oil seeps out, check the engine oil for leaks, and the engine oil passage and the oil pump for damage.
- Check the oil pressure again.
- Tighten the oil pressure check bolt.



Oil pressure check bolt
10 N·m (1.0 kgf·m, 7.4 lb-ft)

EAM30216

ADJUSTING THE CLUTCH LEVER FREE PLAY

1. Check:

- Clutch lever free play "a"

Out of specification → Regulate.



Clutch lever free play
7.0–12.0 mm (0.28–0.47 in)

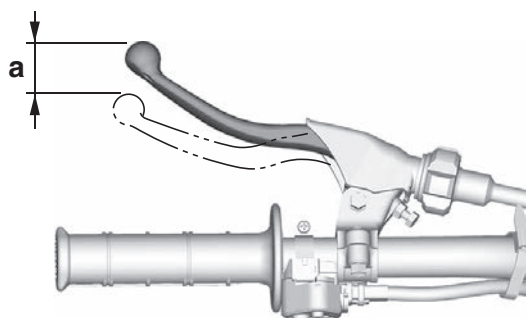

2. Adjust:

- Clutch lever free play

Handlebar side

- Turn the adjuster "1" until the specified clutch lever free play is obtained.

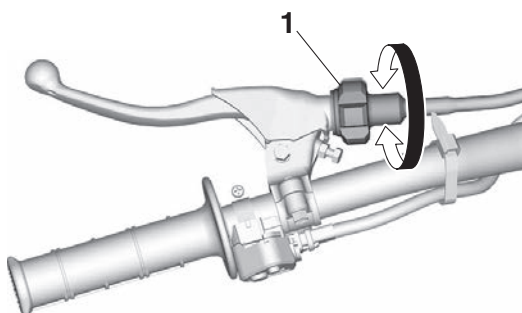

TIP

If the clutch lever free play cannot be obtained on the handlebar side, use the adjuster on the clutch cable side.

Clutch cable side

- Slide the clutch cable cover.
- Loosen the locknut "1".
- Turn the adjuster "2" until the specified clutch lever free play is obtained.
- Tighten the locknut "1".



Clutch cable locknut
4.3 N·m (0.43 kgf·m, 3.2 lb-ft)

- Return the clutch cable cover to its original position.

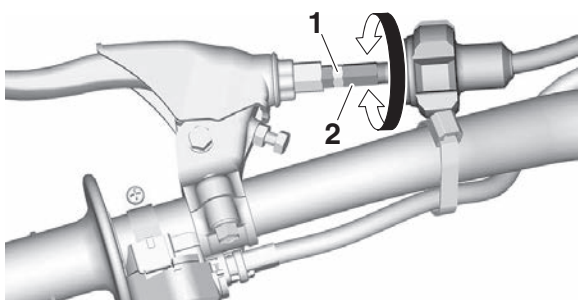

EAM30370

ADJUSTING THE CLUTCH LEVER POSITION

1. Adjust:

- Clutch lever position "a"
Loosen the locknut "1" and use the adjuster "2" to adjust the clutch lever position "a" as desired.

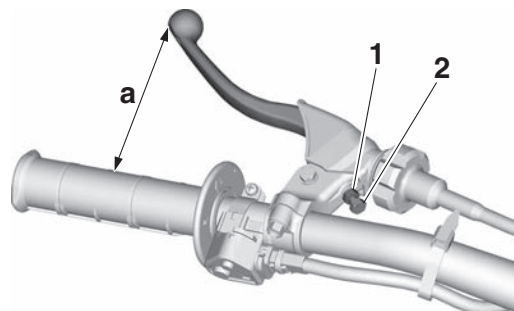

2. Tighten:

- Locknut



Locknut (clutch lever position)
4.8 N·m (0.48 kgf·m, 3.5 lb-ft)

EAM30219

CLEANING THE AIR FILTER ELEMENT

1. Remove:

- Sub-seat
Refer to "FUEL TANK CAP" on page 1-16.
- Air filter case cover "1"

TIP

To remove the air filter case cover:

- Raise the air filter case cover rear side while pushing the side "a" of the air intake duct from inside to unhook the ribs "b" on both sides of the air filter case cover from the air filter case "2".
- Slide the air filter case cover to the rear of the vehicle to remove the projection "c" from the hole "d" in the air filter case.

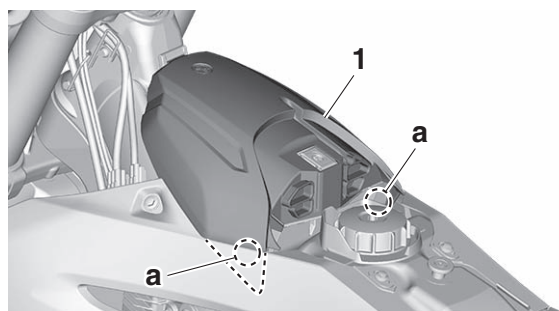

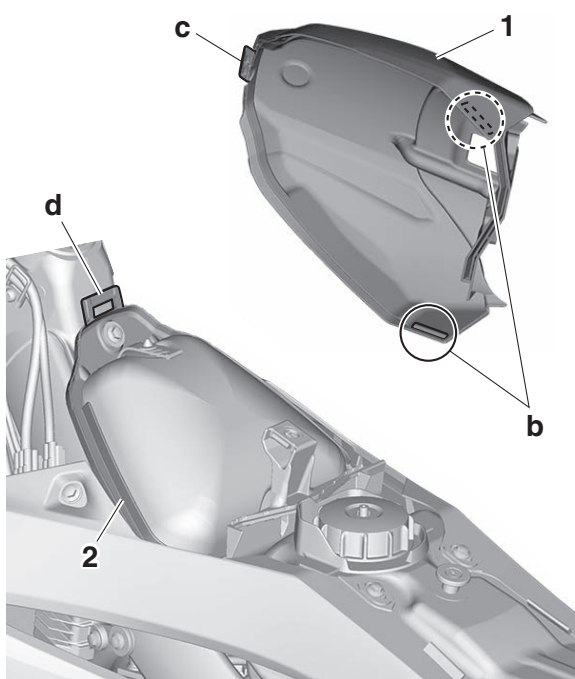

2. Remove:
- Air filter element guide “1”
 - Air filter element “2”
(from the air filter element guide)
 - Seal “3”
(from the air filter element)

TIP

To remove the air filter element:

- Release the band “a” from the projection “b”, and then move the air filter case assembly bracket “4” in the direction of the arrow to release the projection “c”.
- Remove the air filter element and the air filter element guide as a set.

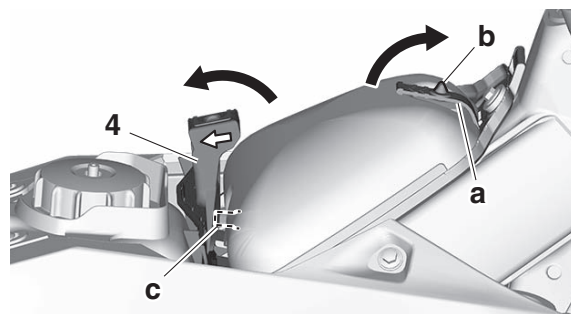
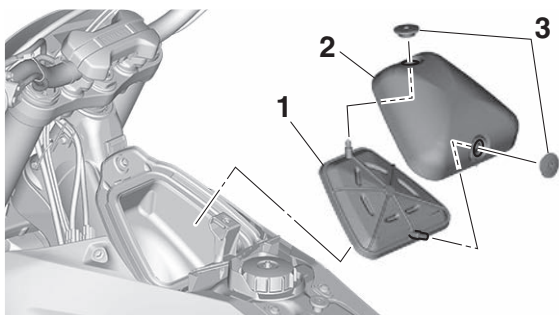

3. Wash:
- Air filter element
 - After washing the element with air filter cleaner or kerosene, squeeze and dry it completely.

EWA19110

WARNING

Do not use gasoline or organic (acid/alkaline) volatile oil for washing.

ECA24280

NOTICE

Do not twist the element when squeezing the element.

4. Check:
- Air filter element
Damage → Replace.
5. Apply:
- Yamaha foam air filter oil or other quality foam air filter oil
 - Put the air filter element into a plastic bag and drip the filter oil into the bag.
 - With the element inside the bag, rub it thoroughly so that the element is evenly permeated with the oil.
 - Wrap the element in a clean cloth, rub the element gently, and wipe off any excess oil.

TIP

- The element should be permeated with oil so that it is wet but not dripping.
- When replacing the element, permeate the element in oil by using the same procedure as when cleaning.

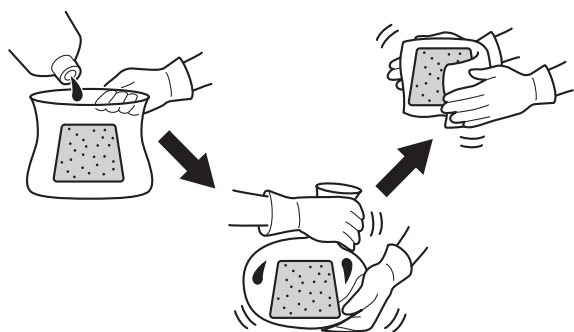

6. Install:

- Air filter case assembly bracket (if removed)
- Seal "1" (to the air filter element)
- Air filter element "2" (to the air filter element guide)
- Air filter element guide "3"

TIP

- Apply lithium-soap-based grease on the entire seal lips when installing the air filter element guide.
- To install the air filter element:
 - Move the air filter case assembly bracket "4" to the rear of the vehicle.
 - Set the projection "a" on the air filter element guide to the air filter case assembly bracket and insert the projection "b" on the air filter element guide to the band "c".

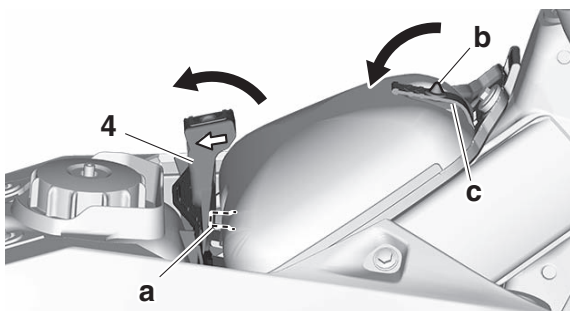
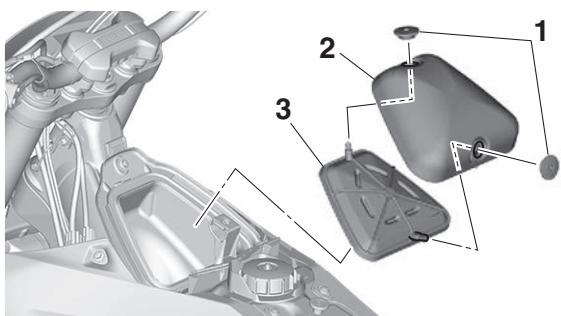

7. Install:

- Air filter case cover "1"
- Fuel tank breather hose "2"

(to the air filter case cover)

TIP

- To install the air filter case cover:
 - Insert the projection "a" on air filter case cover to the hole "b" in the air filter case "3".
 - Push the rear side of the air filter case cover to hook the ribs "c" to the air filter case.
- Insert the fuel tank breather hose end with the protector into the steering shaft hole.
- Fit the other end of the fuel tank breather hose into the projection on the fuel tank cap.
- Route the fuel tank breather hose through the guide "d", and then fit it into the groove "e" in the air filter case cover.

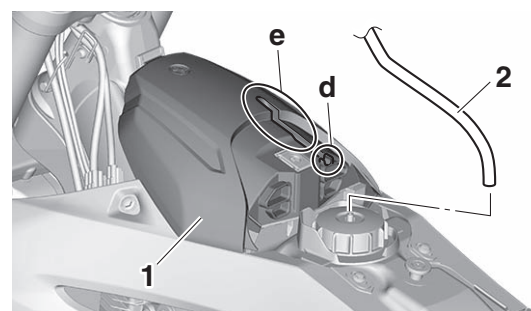
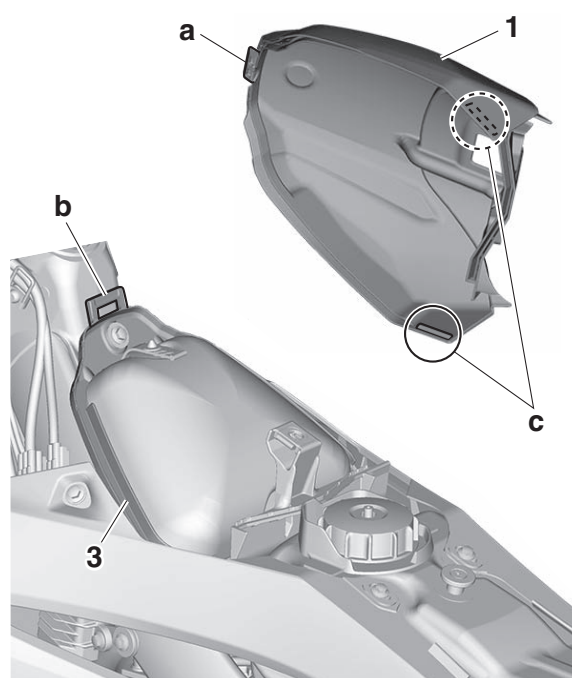

8. Install:

- Sub-seat

EAM30335

CHECKING THE THROTTLE BODY JOINT

1. Check:

- Throttle body joint "1"
- Crack/damage → Replace.

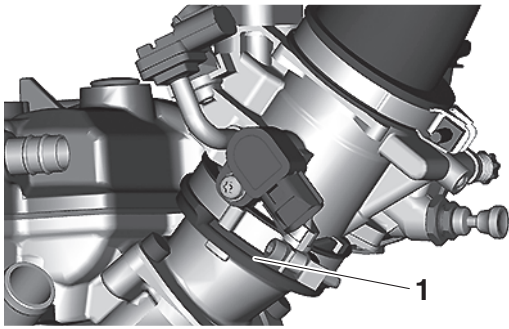

EAM30222

CHECKING THE FUEL LINE

1. Remove:
 - Seat
 - Side cover (left/right)
 - Shroud (left/right)
 - Fuel tank
 Refer to "FUEL TANK" on page 6-1.
2. Check:
 - Fuel hose "1"
 Crack/damage → Replace.
 Loose connection → Connect properly.

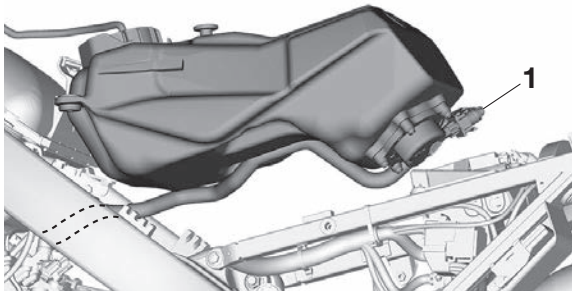

3. Install:
 - Fuel tank
 Refer to "FUEL TANK" on page 6-1.
 - Shroud (left/right)
 - Side cover (left/right)
 - Seat
 Refer to "GENERAL CHASSIS" on page 4-1.

EAM30476

CHECKING THE CYLINDER HEAD BREATHER HOSE

1. Check:
 - Breather hose "1"
 Crack/damage → Replace.
 Loose connection → Connect properly.

ECA14920

NOTICE

Make sure the cylinder head breather hose is routed correctly.

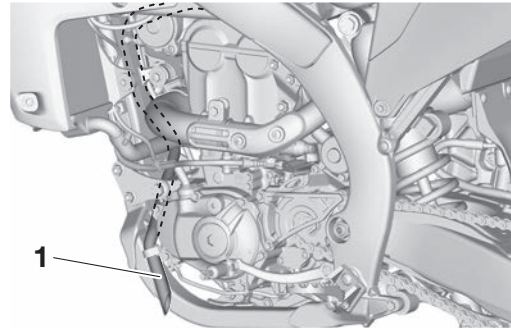

EAM30221

CHECKING THE EXHAUST SYSTEM

1. Remove:
 - Exhaust pipe 1
 - Exhaust pipe 2
 Refer to "EXHAUST SYSTEM" on page 5-1.
2. Remove:
 - Exhaust pipe protector
3. Check:
 - Exhaust pipe 1
 - Exhaust pipe 2
 - Silencer
 Crack/damage → Replace.
4. Check:
 - Silencer fiber
 Damage → Replace.
5. Replace:
 - Silencer fiber
 - a. Remove the bolts "1" and silencer body "2".

ECA25800

NOTICE

Do not hit the silencer stay "a" as it may do damage to the silencer.

TIP

Remove the inner pipe while holding the silencer in place with a vise etc.

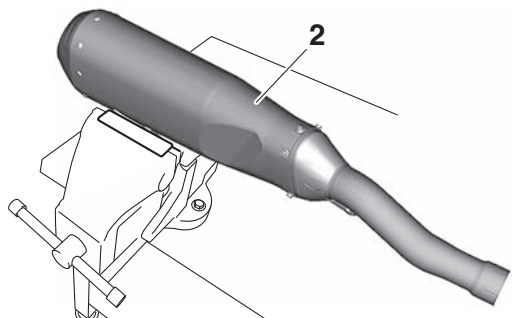
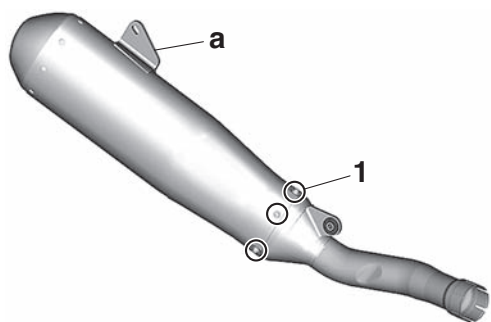

b. Remove the rivets "3" and silencer cap "4".

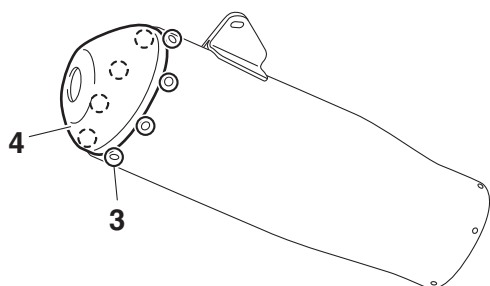

c. Replace the fiber inserts "5".

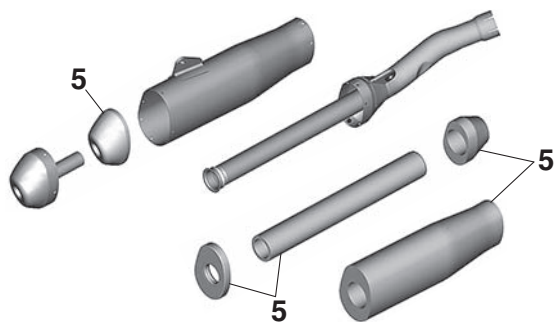

d. Install the fiber insert "6" to the part "b".
e. Twist the fiber insert "7" onto the inner pipe "c".

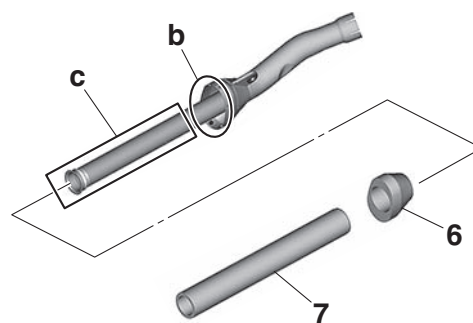

f. Install the silencer body "8" and bolts "9".



Silencer body bolt
8 N·m (0.8 kgf·m, 5.9 lb·ft)
LOCTITE®

TIP

Apply heat-resistant sealant to the areas "d" shown, making sure that there are no gaps in the beads of sealant.

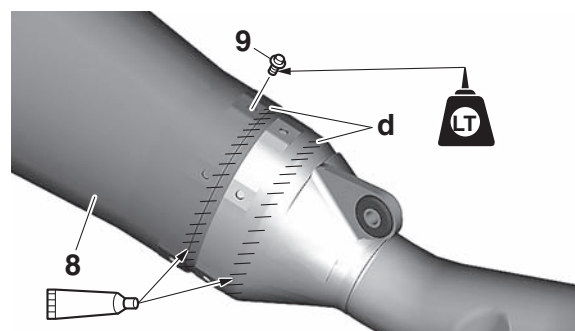

g. Install the fiber "10".

TIP

Stuff the fiber into the silencer body by using a flat board "11".

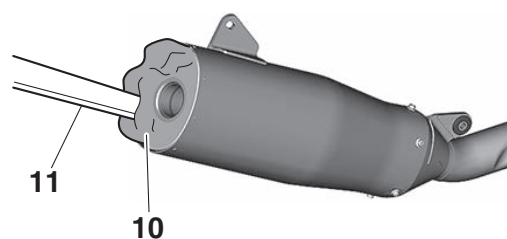

h. Install the fiber insert "12" to the inner pipe.

i. Install the fiber insert "13" to the inside of the silencer cap "14".

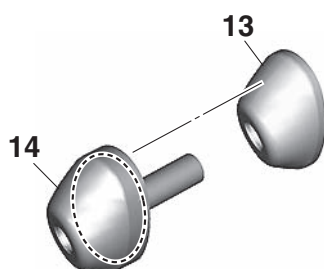
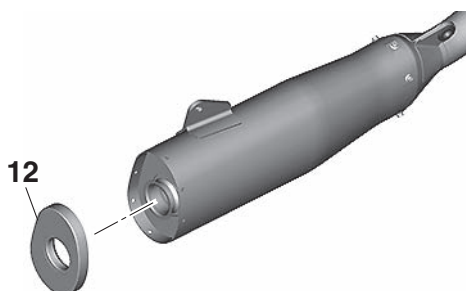

7. Check:

- Tightening torques



Exhaust pipe nut "1"
 10 N·m (1.0 kgf·m, 7.4 lb-ft)
Exhaust pipe clamp bolt "2"
 12 N·m (1.2 kgf·m, 8.9 lb-ft)
Exhaust pipe clamp bolt "3"
 12 N·m (1.2 kgf·m, 8.9 lb-ft)
Silencer bolt (rear) "4"
 30 N·m (3.0 kgf·m, 22 lb-ft)

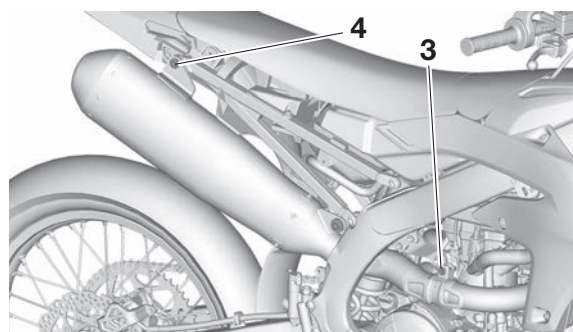
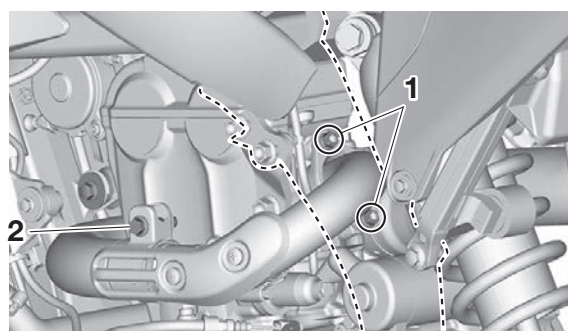

j. Install the silencer cap "15" and rivet "16".

TIP

- Apply heat-resistant sealant to the areas "e" shown, making sure that there are no gaps in the beads of sealant.
- Take care not to allow the fiber out of place when installing the silencer body "17".

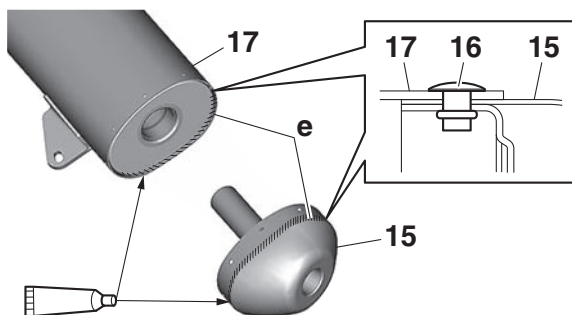

8. Install:

- Exhaust pipe protector



Exhaust pipe protector screw
 10 N·m (1.0 kgf·m, 7.4 lb-ft)
LOCTITE®

6. Check:

- Gasket "1"
- Damage → Replace.

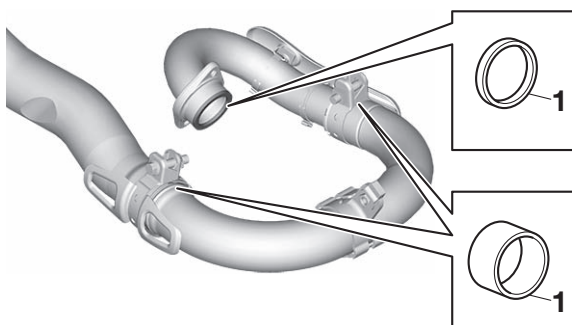

EAM30210

CHECKING THE COOLANT LEVEL

EWA13030



WARNING

A hot radiator is under pressure. Therefore, do not remove the radiator cap when the engine is hot. Scalding hot fluid and steam may be blown out, which could cause serious injury. When the engine has cooled, open the radiator cap as follows:

Place a thick rag or a towel over the radiator cap and slowly turn the radiator cap counter-clockwise toward the detent to allow any residual pressure to escape. When the hissing sound has stopped, press down on the radi-

ator cap and turn it counterclockwise to remove.

1. Stand the vehicle upright on a level surface.
2. Remove:
 - Radiator cap "1"

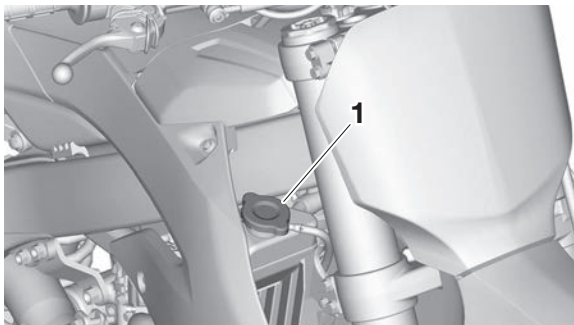

3. Check:
 - Coolant level
Maximum level "a" or below → Add coolant up to the maximum level.

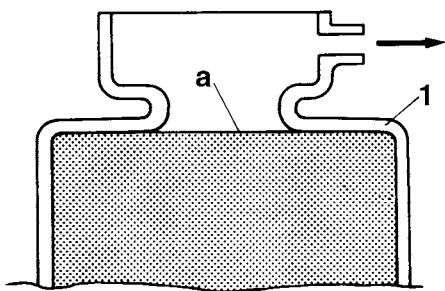

1. Radiator

ECA24260

NOTICE

- Adding water instead of coolant lowers the antifreeze content. If, therefore, water is used instead of coolant, check, and if necessary, adjust the antifreeze concentration.
- Use only distilled water. However, if distilled water is not available, soft water may be used.

4. Start the engine, warm this up for several minutes, and then stop it.

5. Check:
 - Coolant level

TIP

Before checking the coolant level, wait a few minutes until the coolant has settled.

EAM30211

CHECKING THE COOLING SYSTEM

1. Remove:
 - Seat

- Side cover (left/right)
 - Shroud (left/right)
2. Check:
 - Radiator
 - Radiator hose
Crack/damage → Replace.
 3. Install:
 - Shroud (left/right)
 - Side cover (left/right)
 - Seat

Refer to "GENERAL CHASSIS" on page 4-1.

EAM30212

CHANGING THE COOLANT

EWA13030

WARNING

A hot radiator is under pressure. Therefore, do not remove the radiator cap when the engine is hot. Scalding hot fluid and steam may be blown out, which could cause serious injury. When the engine has cooled, open the radiator cap as follows:

Place a thick rag or a towel over the radiator cap and slowly turn the radiator cap counterclockwise toward the detent to allow any residual pressure to escape. When the hissing sound has stopped, press down on the radiator cap and turn it counterclockwise to remove.

1. Place a container under the engine.
2. Remove:
 - Coolant drain bolt "1"

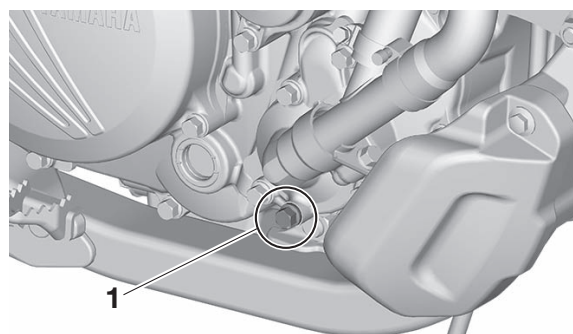

3. Remove:
 - Radiator cap
Slowly loosen the radiator cap to drain coolant.

TIP

When the radiator cap is loosened, coolant will gush out transversely; therefore, bring the container near to the outlet.

4. Thoroughly flush the cooling system with clean tap water.

5. Install:

- Copper washer **New**
- Coolant drain bolt

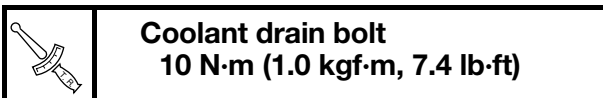

6. Pour coolant.

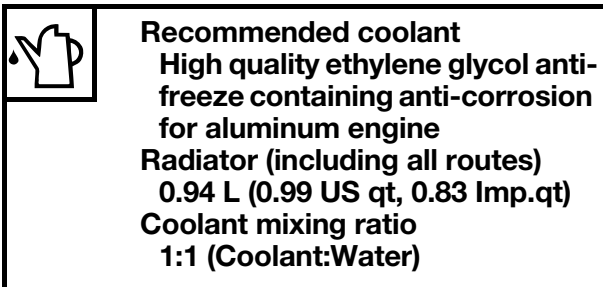

EWA13040

WARNING

- If coolant splashes in your eyes, thoroughly wash them with water and consult a doctor.
- If coolant splashes on your clothes, quickly wash it away with water and then with soap and water.
- If coolant is swallowed, induce vomiting and get immediate medical attention.

ECA13481

NOTICE

- Adding water instead of coolant lowers the antifreeze content of the coolant. If water is used instead of coolant, check, and if necessary, correct the antifreeze concentration of the coolant.
- Use only distilled water. However, if distilled water is not available, soft water may be used.
- If coolant comes into contact with painted surfaces, immediately wash them with water.
- Do not mix different types of antifreeze.

7. Install:

- Radiator cap

8. Start the engine, warm this up for several minutes, stop it, and then wait for it to cool down.

9. Check:

- Coolant level
Refer to "CHECKING THE COOLANT LEVEL" on page 3-17.

EAM20136

CHASSIS

EAM30479

ADJUSTING THE FRONT DISC BRAKE

TIP

There should be no free play at the brake lever end.

1. Check:
 - Brake lever position “a”

	Brake lever position
	100 mm (3.94 in)
	Extent of adjustment
	86–105 mm (3.39–4.13 in)

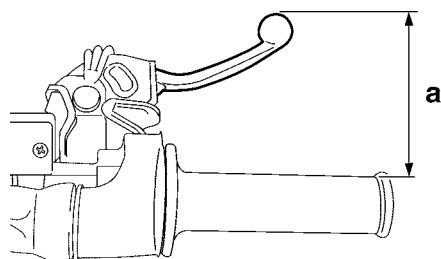

2. Remove:
 - Brake lever cover
3. Adjust:
 - Brake lever position
 - a. Loosen the locknut “1”.
 - b. Turn the adjusting bolt “2” until the specified brake lever position is obtained.

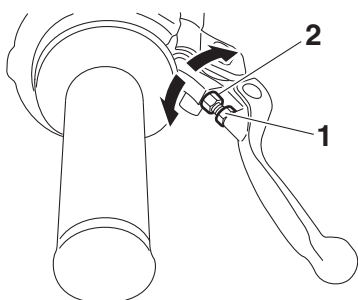

- c. Tighten the locknut.

	Locknut
	5 N·m (0.5 kgf·m, 3.7 lb-ft)

EWA13050

WARNING

A soft or spongy feeling in the brake lever can indicate the presence of air in the brake system. Before the vehicle is operated, the air must be removed by bleeding the brake

system. Air in the brake system will considerably reduce braking performance.

ECA13490

NOTICE

After adjusting the brake lever position, make sure there is no brake drag.

4. Install:
 - Brake lever cover

EAM30480

ADJUSTING THE REAR DISC BRAKE

1. Adjust:
 - Brake pedal position
 - a. Loosen the locknut “1”.
 - b. Turn the adjusting bolt “2” until the brake pedal is in the correct position.

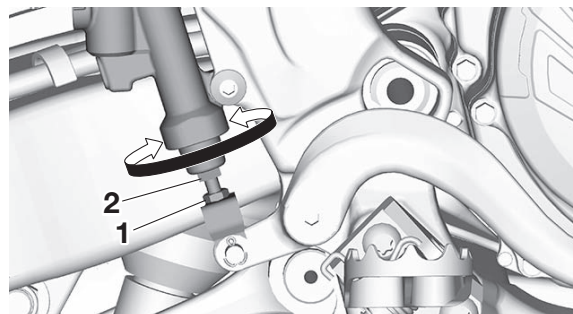

- c. Tighten the locknut.

	Locknut
	6 N·m (0.6 kgf·m, 4.4 lb-ft)

EWA19150

WARNING

A soft or spongy feeling in the brake pedal can indicate the presence of air in the brake system. Before running, bleed the brake system. Air in the brake system will cause braking performance to be reduced.

ECA13510

NOTICE

After adjusting the brake pedal position, make sure there is no brake drag.

EAM30234

CHECKING THE BRAKE FLUID LEVEL

1. Stand the vehicle upright on a level surface.

TIP

In order to ensure a correct reading of the brake fluid level, make sure that the top of the brake fluid reservoir is horizontal.

2. Check:
 - Brake fluid level

The minimum level mark “a” or below →

Add.

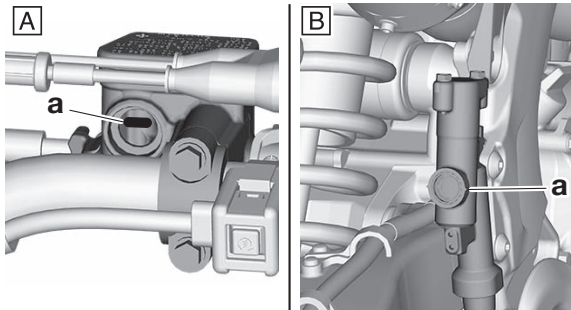

- A. Front brake
- B. Rear brake

EWA13090

WARNING

- Use only the designated brake fluid. Other brake fluids may cause the rubber seals to deteriorate, causing leakage and poor brake performance.
- Refill with the same type of brake fluid that is already in the system. Mixing brake fluids may result in a harmful chemical reaction, leading to poor brake performance.
- When refilling, be careful that water does not enter the brake fluid reservoir. Water will significantly lower the boiling point of the brake fluid and could cause vapor lock.

ECA13540

NOTICE

Brake fluid may damage painted surfaces and plastic parts. Therefore, always clean up any spilt brake fluid immediately.

EAM30231

CHECKING THE FRONT BRAKE PADS

The following procedure applies to all of the brake pads.

1. Operate the brake.
2. Check:
 - Front brake pad
Wear indicator grooves "1" almost touch the brake disc → Replace the brake pads as a set.
Refer to "FRONT BRAKE" on page 4-6.

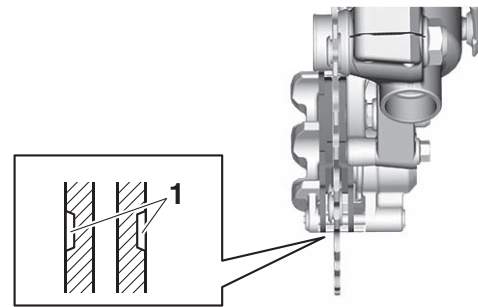

EAM30232

CHECKING THE REAR BRAKE PADS

The following procedure applies to all of the brake pads.

1. Operate the brake.
2. Check:
 - Rear brake pad
Wear indicator grooves "1" almost touch the brake disc → Replace the brake pads as a set.
Refer to "REAR BRAKE" on page 4-8.

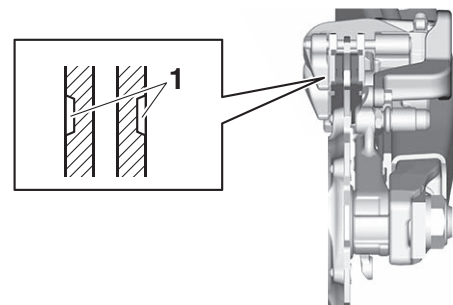

EAM30478

CHECKING THE FRONT BRAKE HOSE

1. Check:
 - Brake hose
Cracks/damage/wear → Replace.
2. Check:
 - Brake hose clamp
Loose connection → Tighten the clamp bolt.
3. Stand the vehicle upright and apply the front brake several times.
4. Check:
 - Brake hose
Brake fluid leaks → Replace the damaged brake hose.
5. Check:
 - Protector "1"
Out of specification → Replace.

TIP

The protector reaches the limit of its use when it is worn down to the same height "a" as of the plastic locking tie circumference.

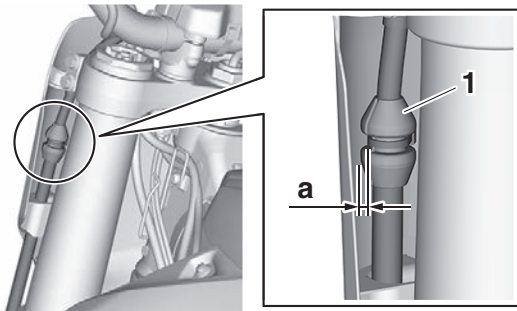

EAM30498

CHECKING THE REAR BRAKE HOSE

1. Check:
 - Brake hose
Cracks/damage/wear → Replace.
2. Check:
 - Brake hose holder
Loose connection → Tighten the holder bolt.
3. Hold the vehicle upright and apply the rear brake several times.
4. Check:
 - Brake hose
Brake fluid leakage → Replace the damaged hose.

EAM30499

CHECKING THE BRAKE OPERATION

1. Check:
 - Brake operation
Brake not working properly → Check the brake system.

TIP

Drive on the dry road, operate the front and rear brakes separately and check to see if the brakes are operating properly.

EAM30477

BLEEDING THE HYDRAULIC BRAKE SYSTEM

EWA19140

⚠ WARNING

Bleed the brake system whenever:

- The system is disassembled.
- A brake hose is loosened, disconnected, or replaced.
- The brake fluid level is very low.
- Brake operation is faulty.

1. Remove:
 - Brake master cylinder cap
 - Reservoir diaphragm
 - Reservoir float (front brake)
 - Protector (rear brake)

TIP

- Be careful not to spill any brake fluid or allow

the reservoir to overflow.

- Make sure that there is enough brake fluid before applying the brake. Ignoring this precaution could allow air to enter the brake system, considerably lengthening the bleeding procedure.
- If bleeding is difficult, it may be necessary to let the brake fluid settle for a few hours. Repeat the bleeding procedure when the tiny bubbles in the hose have disappeared.

2. Bleed the brake system.

- a. Fill the reservoir to the proper level with the recommended brake fluid.
- b. Install the reservoir diaphragm.
- c. Connect the plastic hose "1" to the bleed screw "2" securely, and place a container under the end of the plastic hose.

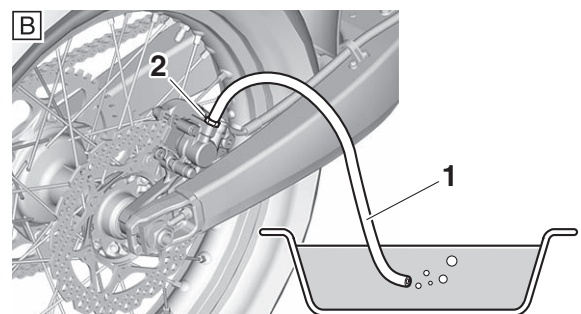
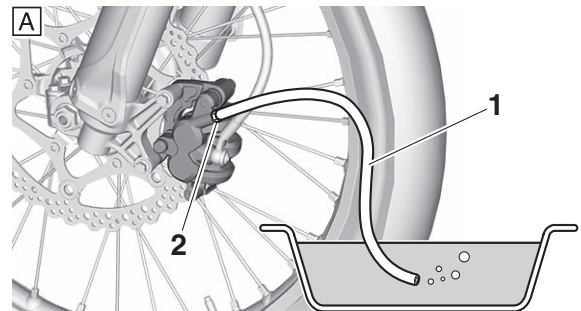

A. Front

B. Rear

- d. Slowly apply the brake several times.
- e. Fully pull the brake lever or fully press down the brake pedal and hold it in position.
- f. Loosen the bleed screw.

TIP

Loosening the bleed screw will release the pressure in the brake caliper and cause the brake lever to contact the throttle grip or the brake pedal to fully extend.

- g. Tighten the bleed screw and then release the brake lever or brake pedal.

- h. Repeat steps (d) to (g) until all of the air bubbles have disappeared from the brake fluid in the plastic hose.

TIP

During the procedure, keep adding brake fluid to the reservoir.

ECA24320

NOTICE

- Wipe off any brake fluid on the brake discs, tires, wheels, etc.
- Brake fluid may erode painted surfaces or plastic parts. Always clean up spilled fluid immediately.

- i. Tighten the bleed screw.

	Bleed screw 5 N·m (0.5 kgf·m, 3.7 lb·ft)
---	--

- j. Pour brake fluid to the reservoir up to the specified level.
Refer to “CHECKING THE BRAKE FLUID LEVEL” on page 3-20.

EWA13110

WARNING

After bleeding the hydraulic brake system, check the brake operation.

EAM30481

DRIVE CHAIN SLACK

ECA13550

NOTICE

A drive chain that is too tight will overload the engine and other vital parts, and one that is too loose can skip and damage the swing-arm or cause an accident. Therefore, keep the drive chain slack within the specified limits.

Checking the drive chain slack

1. Use a maintenance stand to raise the rear wheel off the ground.

EWA13120

WARNING

Securely support the vehicle so that there is no danger of it falling over.

2. Shift the transmission into the neutral position.
3. Pull the drive chain up above the drive chain guide installation bolt with a force of about 50 N (5.0 kgf, 37 lbf).
4. Check:
 - Drive chain slack “a”
Out of specification → Regulate.

TIP

Measure drive chain slack between the drive chain guide and the bottom of the chain as shown.

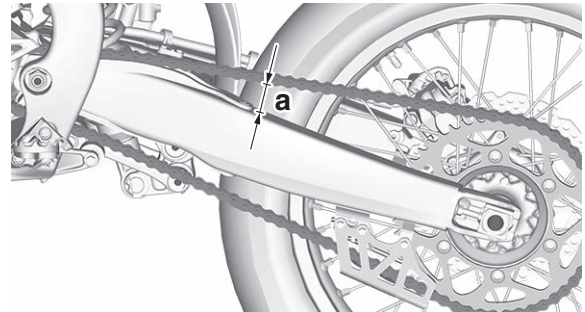

Drive chain slack (Maintenance Stand)
50.0–60.0 mm (1.97–2.36 in)

Adjusting the drive chain slack

EWA13120

WARNING

Securely support the vehicle so that there is no danger of it falling over.

1. Adjust:
 - Drive chain slack
 - a. Loosen the wheel axle nut “1”.
 - b. Loosen both locknuts “2”.
 - c. Turn the adjusting bolt “3” until the specified drive chain slack is obtained.

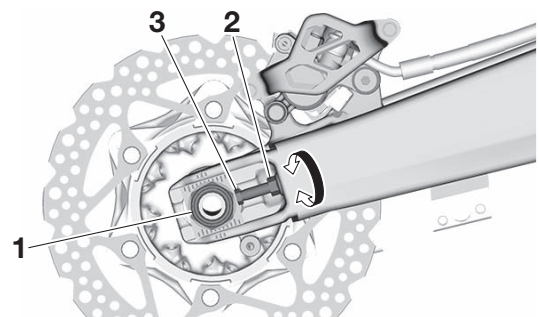

TIP

- To maintain the proper wheel alignment, adjust both sides evenly.
- Push the rear wheel forward to make sure that there is no clearance between the swingarm end plates and the ends of the swingarm.

- d. Tighten the wheel axle nut.



Wheel axle nut
135 N·m (13.5 kgf·m, 100 lb·ft)

- e. Tighten the drive chain puller locknut.



Drive chain puller locknut
21 N·m (2.1 kgf·m, 15 lb·ft)

EAM30247

CHECKING AND ADJUSTING THE STEERING HEAD

1. Use a maintenance stand to raise the front wheel off the ground.

EWA13120

WARNING

Securely support the vehicle so that there is no danger of it falling over.

2. Check:
 - Steering head
 Grasp the bottom of the front fork legs and gently rock the front fork.
 Blinding/looseness → Adjust the steering head.
3. Remove:
 - Handlebar
 - Upper bracket
4. Adjust:
 - Steering head
 - a. Remove the washer “1”.

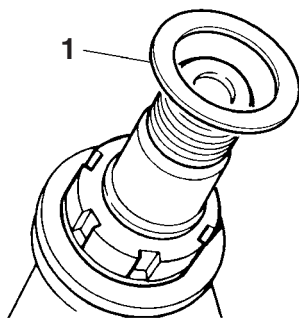

- b. After loosening the ring nut “2” with a steering nut wrench “3”, tighten it to the specified torque.

TIP

- Set the torque wrench at a right angle to the steering nut wrench.
- Move the steering to the left and right a couple of times to check that it moves smoothly.

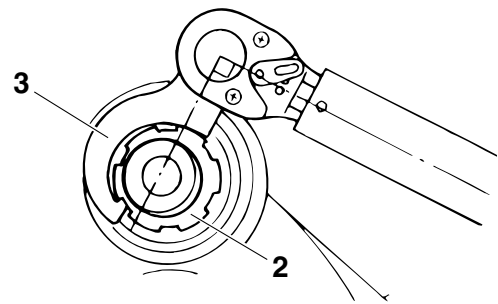

Steering nut wrench
90890-01403
Exhaust flange nut wrench
YU-A9472



Ring nut (initial tightening torque)
38 N·m (3.8 kgf·m, 28 lb·ft)

- c. Turn the front fork to the right and left a few times, and make sure that the steering rotates smoothly. If it does not turn smoothly, remove the lower bracket and check the upper and lower bearings. Refer to “STEERING HEAD” on page 4-25.
- d. Loosen the ring nut fully turn and then tighten it to specification with a steering nut wrench.

EWA13140

WARNING

Do not overtighten the lower ring nut.



Ring nut (final tightening torque)
7 N·m (0.7 kgf·m, 5.2 lb·ft)

- e. Check the steering head for looseness or binding by turning the front fork all the way in both directions. If any binding is felt, remove the lower bracket and check the upper and lower bearings. Refer to “STEERING HEAD” on page 4-25.
- f. Install the washer “1”.

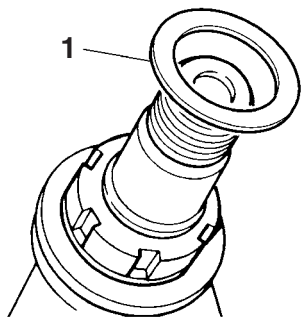

5. Install:
- Upper bracket
 - Handlebar
- Refer to "HANDLEBAR" on page 4-10.

EAM30502

LUBRICATING THE STEERING HEAD

1. Lubricate:
- Upper bearing
 - Lower bearing
 - Bearing race



Recommended lubricant
Lithium-soap-based grease

EAM30338

CHECKING THE FRONT FORK LEGS

1. Stand the vehicle upright on a level surface.

EWA13120



WARNING

Securely support the vehicle so that there is no danger of it falling over.

2. Check:
- Inner tube
Damage/scratches → Replace.
 - Front fork leg
Oil leaks between inner tube and outer tube → Replace the oil seal.
3. Hold the vehicle upright and apply the front brake.
4. Check:
- Front fork operation
Push down hard on the handlebar several times and check if the front fork rebounds smoothly.
Unsmooth operation → Correct or replace.
Refer to "FRONT FORK" on page 4-15.

TIP

If any damage is found or the front fork does not operate smoothly, have a Yamaha dealer check or repair it.

5. Check:
- Protector guide "1"

Out of specification → Replace.

TIP

The protector guide reaches the limit of its use when it is worn down to the same height "a" as of the outer tube circumference.

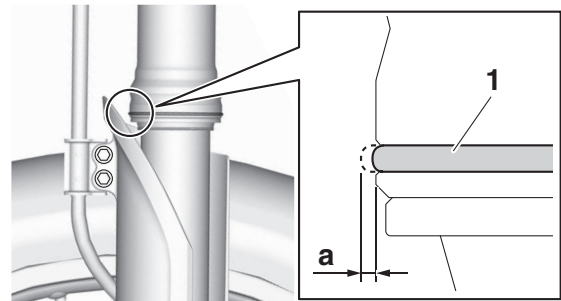

6. Remove:
- Protector
 - Dust seal "1"

ECA24330

NOTICE

Be careful not to damage the dust seal and the inner tube by a driver.

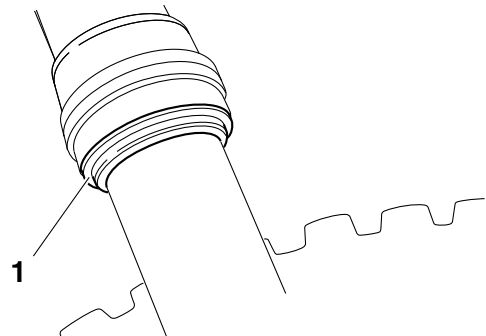

7. Clean:
- Dust seal "a"
 - Oil seal "b"

TIP

- Clean the dust seal and oil seal after every run.
- Apply lithium-soap-based grease on the inner tube.

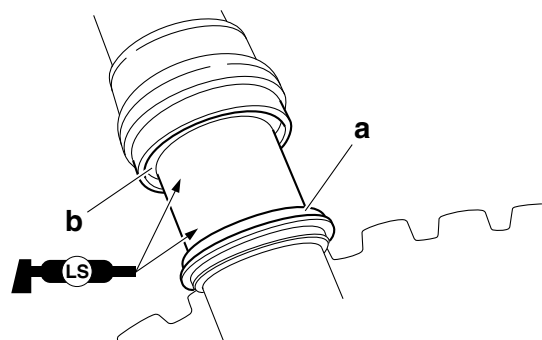

EAM30239

ADJUSTING THE FRONT FORK LEGS

EWA19180

WARNING

- Always adjust the left and right front forks evenly. If this is not done, the vehicle may have poor stability.
- Securely support the vehicle so that there is no danger of it falling over.

Rebound damping

ECA24340

NOTICE

Do not turn the adjuster forcibly beyond its adjusting range.

- Adjust:
 - Rebound damping
 - Turn the adjuster "1" in the direction of "a" or "b" to make an adjustment.

Direction "a"

Rebound damping is increased (suspension is harder).

Direction "b"

Rebound damping is decreased (suspension is softer).



Rebound damping

Minimum (soft)

20 click(s) in direction "b"*

Standard

7 click(s) in direction "b"* (CAN)

9 click(s) in direction "b"* (AUS, AUT, BEL, CHE, CYP, CZE, DEU, DNK, ESP, FIN, FRA, GBR, GRC, HRV, HUN, IRL, ITA, NLD, NOR, NZL, POL, PRT, SVK, SVN, SWE, TUR, ZAF)

Maximum (hard)

0 click(s) in direction "b"*

*With the adjusting screw fully turned in direction "a"

TIP

Although the total number of clicks of a damping force adjusting mechanism may not exactly match the above specifications due to small differences in production, the actual number of clicks always represents the entire adjusting range. To obtain a precise adjustment, it would be advisable to check the number of clicks of each damping force adjusting mechanism and to modify the specifications as necessary.

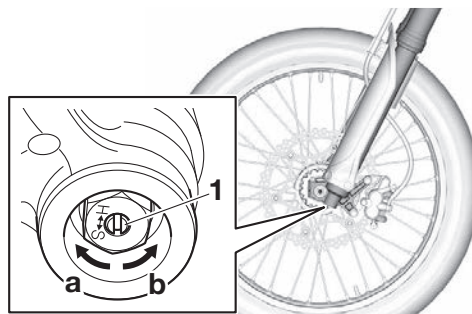

Compression damping

ECA24350

NOTICE

Do not turn the adjuster forcibly beyond its adjusting range.

- Adjust:
 - Compression damping
 - Turn the adjuster "1" in the direction of "a" or "b" to make an adjustment.

Direction "a"

Compression damping is increased (suspension is harder).

Direction "b"

Compression damping is decreased (suspension is softer).



Compression damping

Minimum (soft)

20 click(s) in direction "b"*

Standard

10 click(s) in direction "b"* (CAN)

11 click(s) in direction "b"* (AUS, AUT, BEL, CHE, CYP, CZE, DEU, DNK, ESP, FIN, FRA, GBR, GRC, HRV, HUN, IRL, ITA, NLD, NOR, NZL, POL, PRT, SVK, SVN, SWE, TUR, ZAF)

Maximum (hard)

0 click(s) in direction "b"*

*With the adjusting screw fully turned in direction "a"

TIP

Although the total number of clicks of a damping force adjusting mechanism may not exactly match the above specifications due to small differences in production, the actual number of clicks always represents the entire adjusting range. To obtain a precise adjustment, it would be advisable to check the number of clicks of each damping force adjusting mechanism and to modify the specifications as necessary.

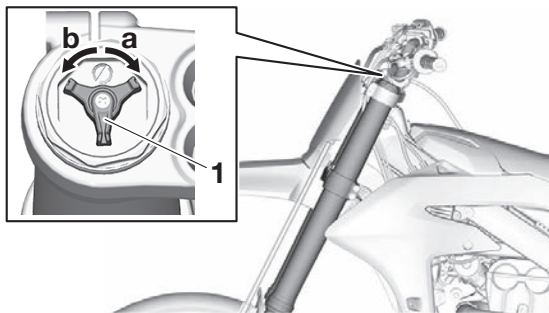

Air bleeding from front fork

TIP

If the front fork initial movement feels stiff during a run, relieve the front fork internal pressure.

1. Use a maintenance stand to raise the front wheel off the ground.

EWA13120

WARNING

Securely support the vehicle so that there is no danger of it falling over.

2. Remove the bleed screw "1" and release the internal pressure from the front fork.
3. Tighten:
 - Bleed screw

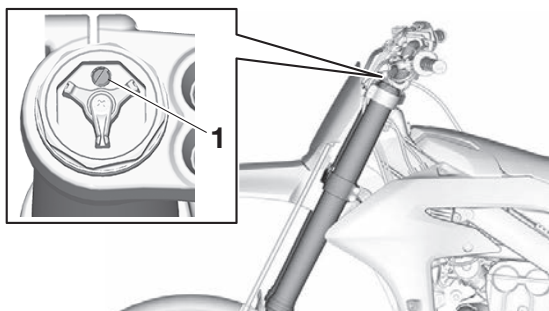
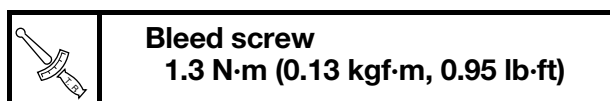

EAM30482

CHECKING THE REAR SHOCK ABSORBER ASSEMBLY

1. Stand the vehicle upright on a level surface.

EWA13120

WARNING

Securely support the vehicle so that there is no danger of it falling over.

2. Check:
 - Rear shock absorber assembly
Gas leaks/oil leaks → Replace the rear shock absorber assembly.
Refer to "REAR SHOCK ABSORBER ASSEMBLY" on page 4-28.

3. Check:

- Rear shock absorber assembly smooth action
- Rear suspension link smooth action
Sit astride the seat and shake your body up and down several times to check whether the rear shock absorber assembly operates smoothly.
Unsmooth operation → Correct or replace.

EAM30242

ADJUSTING THE REAR SHOCK ABSORBER ASSEMBLY

Use a maintenance stand to raise the rear wheel off the ground.

EWA13120

WARNING

Securely support the vehicle so that there is no danger of it falling over.

Spring preload

ECA24360

NOTICE

Do not turn the adjuster forcibly beyond its adjusting range.

1. Adjust:

- Spring preload
 - a. Loosen the locknut "1".
 - b. Loosen the adjuster "2" until there is some clearance between the spring and the adjuster.
 - c. Measure the spring free length "a".

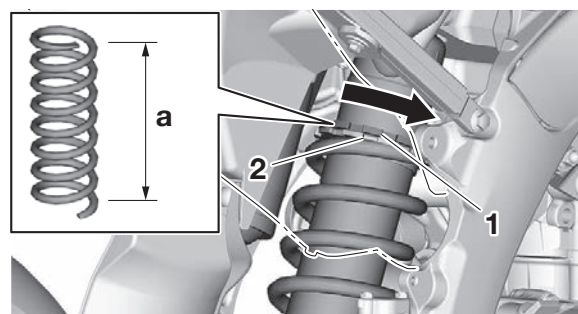

- d. Turn the adjuster in the direction of "b" or "c" to make an adjustment.

Direction "b"

Spring preload is increased (suspension is harder).

Direction "c"

Spring preload is decreased (suspension is softer).



Spring preload adjusting positions

Minimum
Position in which the spring is turned in 1.5 mm (0.06 in) from its free length.

Standard
Position in which the spring is turned in 5.0 mm (0.20 in) from its free length.

Maximum
Position in which the spring is turned in 18.0 mm (0.71 in) from its free length.

TIP

- Be sure to remove all dirt and mud from around the locknut and adjusting ring before adjustment.
- The length of the spring (installed) changes 1.5 mm (0.06 in) per turn of the adjusting ring.

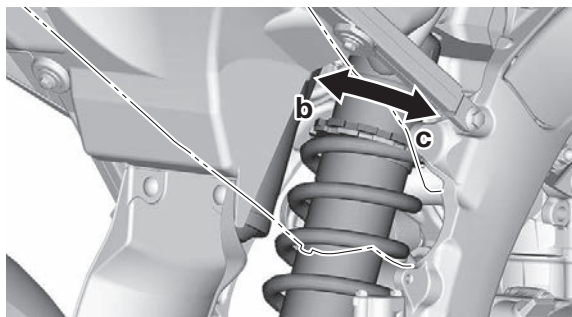

e. Tighten the locknut.

Rebound damping

ECA24370

NOTICE

Do not turn the adjuster forcibly beyond its adjusting range.

- Adjust:
 - Rebound damping
 - Turn the adjuster "1" in the direction of "a" or "b" to make an adjustment.

Direction "a"
Rebound damping is increased (suspension is harder).

Direction "b"
Rebound damping is decreased (suspension is softer).



Rebound damping

Minimum (soft)
30 click(s) in direction "b"*

Standard
10 click(s) in direction "b"* (CAN)
9 click(s) in direction "b"* (AUS, AUT, BEL, CHE, CYP, CZE, DEU, DNK, ESP, FIN, FRA, GBR, GRC, HRV, HUN, IRL, ITA, NLD, NOR, NZL, POL, PRT, SVK, SVN, SWE, TUR, ZAF)

Maximum (hard)
0 click(s) in direction "b"*

*With the adjusting screw fully turned in direction "a"

TIP

Although the total number of clicks of a damping force adjusting mechanism may not exactly match the above specifications due to small differences in production, the actual number of clicks always represents the entire adjusting range. To obtain a precise adjustment, it would be advisable to check the number of clicks of each damping force adjusting mechanism and to modify the specifications as necessary.

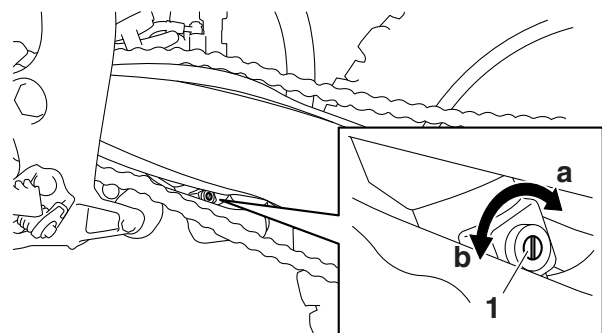

Compression damping (for fast compression damping)

ECA24370

NOTICE

Do not turn the adjuster forcibly beyond its adjusting range.

- Adjust:
 - Compression damping (for fast compression damping)
 - Turn the adjuster "1" in the direction of "a" or "b" to make an adjustment.

Direction “a”
 Compression damping is increased
 (suspension is harder).
Direction “b”
 Compression damping is decreased
 (suspension is softer).

Direction “a”
 Compression damping is increased
 (suspension is harder).
Direction “b”
 Compression damping is decreased
 (suspension is softer).



Fast compression damping
Minimum (soft)
 2 turn(s) in direction “b”^{*}
Standard
 1+1/4 turn(s) in direction “b”^{*}
(CAN)
 7/8 turn(s) in direction “b”^{*} (AUS,
 AUT, BEL, CHE, CYP, CZE, DEU,
 DNK, ESP, FIN, FRA, GBR, GRC,
 HRV, HUN, IRL, ITA, NLD, NOR,
 NZL, POL, PRT, SVK, SVN, SWE,
 TUR, ZAF)
Maximum (hard)
 0 turn(s) in direction “b”^{*}
^{*}With the adjusting screw fully turned in di-
 rection “a”



Slow compression damping
Minimum (soft)
 20 click(s) in direction “b”^{*}
Standard
 10 click(s) in direction “b”^{*} (CAN)
 11 click(s) in direction “b”^{*} (AUS,
 AUT, BEL, CHE, CYP, CZE, DEU,
 DNK, ESP, FIN, FRA, GBR, GRC,
 HRV, HUN, IRL, ITA, NLD, NOR,
 NZL, POL, PRT, SVK, SVN, SWE,
 TUR, ZAF)
Maximum (hard)
 0 click(s) in direction “b”^{*}
^{*}With the adjusting screw fully turned in di-
 rection “a”

TIP
 To obtain a precise adjustment, it is advisable to check the actual total number of turns of the damping force adjusting mechanism. This adjustment range may not exactly match the specifications listed due to small differences in production.

TIP
 Although the total number of clicks of a damping force adjusting mechanism may not exactly match the above specifications due to small differences in production, the actual number of clicks always represents the entire adjusting range. To obtain a precise adjustment, it would be advisable to check the number of clicks of each damping force adjusting mechanism and to modify the specifications as necessary.

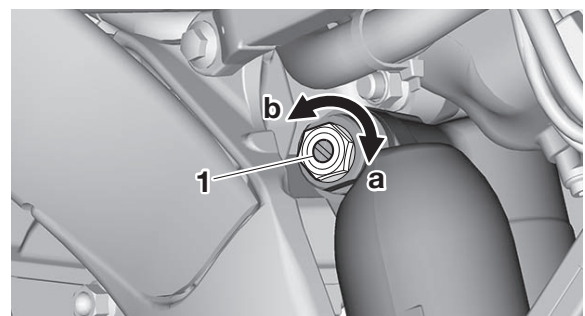
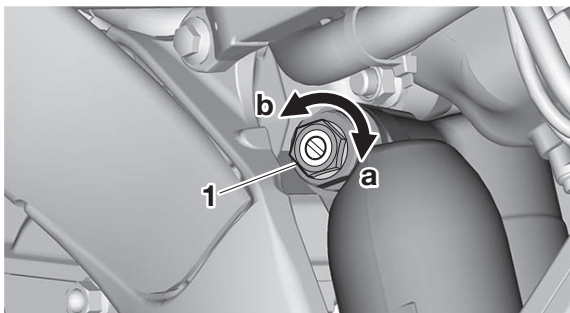

Compression damping (for slow compression damping)

ECA24390

NOTICE

Do not turn the adjuster forcibly beyond its adjusting range.

1. Adjust:
 - Compression damping (for slow compression damping)
 - a. Turn the adjuster “1” in the direction of “a” or “b” to make an adjustment.

EAM30240

CHECKING THE SWINGARM OPERATION

1. Check:
 - Swingarm smooth action
 - Swingarm free play
 Refer to “SWINGARM” on page 4-29.

EAM30500

LUBRICATING THE SWINGARM PIVOT

1. Lubricate:
 - Oil seal

- Collar



EAM30243

CHECKING THE TIRES

1. Measure:

- Tire pressure
Out of specification → Regulate.

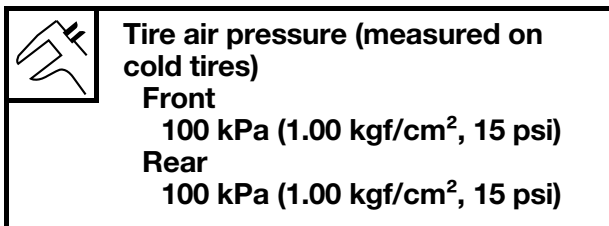

TIP

- Check the tire while it is cold.
- Because if the bead stopper tightening nut is loose when the tire pressure is low, the tire could slip off the rim, thus be sure to check and tighten the bead stopper tightening nut “a”.
- If the tire valve stem “b” is found tilted, the tire is considered to be slipping off its position. Correct the tire position.

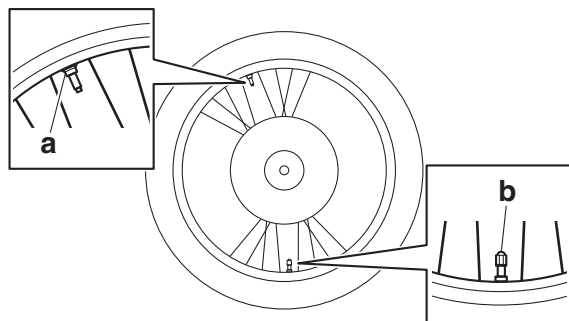

- a. Bead stopper tightening nut
b. Tire valve stem

EAM30244

CHECKING AND TIGHTENING THE SPOKES

1. Check:

- Spoke
Bend/damage → Replace.
Loose → Tighten.
Tap the spokes with a screwdriver.

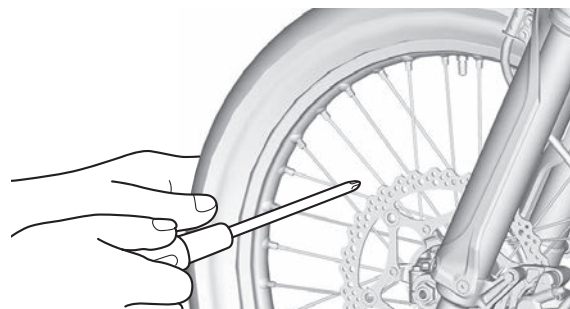

TIP

A tight spoke will emit a clear, ringing tone; a loose spoke will sound flat.

2. Tighten:

- Spoke
(with a spoke nipple wrench “1”)

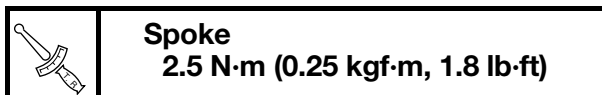
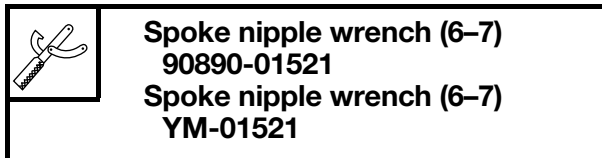
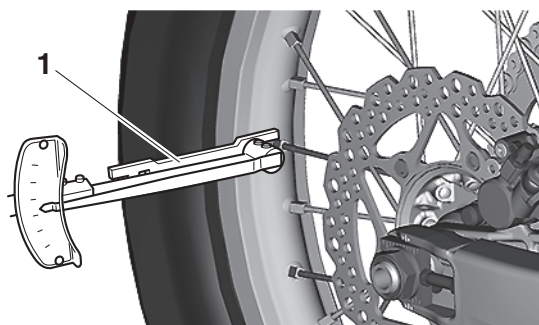

TIP

- Do not give a half turn (180°) or more for one tightening.
- Make sure that tightening after a break-in is done until the initial looseness in nipples disappears.
- Make sure that tightening is done in stages, not at a time.

EAM30245

CHECKING THE WHEELS

1. Check:

- Wheel
Damage/out-of-round → Replace.

EWA13260



WARNING

Never attempt to make any repairs to the

wheel.

EAM30253

CHECKING THE CHASSIS FASTENERS

Make sure that all nuts, bolts, and screws are properly tightened.

Refer to "CHASSIS TIGHTENING TORQUES" on page 2-12.

EAM30248

CHECKING AND LUBRICATING THE CABLES

The following procedure applies to all of the inner and outer cables.

EWA13270

WARNING

Damaged outer cable may cause the cable to corrode and interfere with its movement. Replace damaged outer cable and inner cables as soon as possible.

1. Check:
 - Outer cable
Damage → Replace.
2. Check:
 - Cable operation
Rough movement → Lubricate.

	Recommended lubricant Engine oil or a suitable cable lubricant
---	---

TIP

Hold the cable end upright and pour a few drops of lubricant into the cable sheath or use a suitable lubricating device.

EAM30483

LUBRICATING THE BRAKE LEVER

1. Lubricate the pivoting points and metal-to-metal moving parts of the following parts.
 - Brake lever

	Recommended lubricant Silicone grease
---	--

EAM30503

LUBRICATING THE CLUTCH LEVER

1. Lubricate the pivoting points and metal-to-metal moving parts of the following parts.
 - Clutch lever

	Recommended lubricant Lithium-soap-based grease
---	--

EAM30250

LUBRICATING THE PEDAL

1. Lubricate the pivoting point and metal-to-metal moving parts of the pedal.

	Recommended lubricant Lithium-soap-based grease
---	--

EAM20137

ELECTRICAL SYSTEM

EAM30256

CHECKING AND CHARGING THE BATTERY

Refer to “CHECKING AND CHARGING THE BATTERY” on page 7-1.

EAM30505

CHECKING THE FUSES

Refer to “CHECKING THE FUSES” on page 7-1.

CHASSIS

GENERAL CHASSIS	4-1
REMOVING THE SEAT	4-1
REMOVING THE NUMBER PLATE	4-1
INSTALLING THE SHROUD	4-1
REMOVING THE SIDE COVER.....	4-2
INSTALLING THE SIDE COVER	4-2
FRONT WHEEL	4-3
REMOVING THE FRONT WHEEL	4-3
INSTALLING THE FRONT WHEEL	4-3
REAR WHEEL	4-4
REMOVING THE REAR WHEEL	4-4
CHECKING AND REPLACING THE REAR WHEEL SPROCKET.....	4-4
INSTALLING THE REAR WHEEL	4-4
FRONT BRAKE	4-6
REPLACING THE FRONT BRAKE PADS	4-6
REAR BRAKE	4-8
REPLACING THE REAR BRAKE PADS.....	4-8
HANDLEBAR	4-10
REMOVING THE HANDLEBAR	4-10
CHECKING THE HANDLEBAR.....	4-10
INSTALLING THE HANDLEBAR.....	4-10
FRONT FORK	4-15
REMOVING THE FRONT FORK LEGS	4-15
DISASSEMBLING THE FRONT FORK LEGS	4-15
CHECKING THE FRONT FORK LEGS	4-16
ASSEMBLING THE FRONT FORK LEGS.....	4-17
INSTALLING THE FRONT FORK LEGS	4-23
STEERING HEAD	4-25
REMOVING THE LOWER BRACKET.....	4-25
CHECKING THE STEERING HEAD	4-25
INSTALLING THE STEERING HEAD	4-25
REAR SHOCK ABSORBER ASSEMBLY	4-28
REMOVING THE REAR SHOCK ABSORBER ASSEMBLY	4-28
CHECKING THE REAR SHOCK ABSORBER ASSEMBLY	4-28
SWINGARM	4-29
REMOVING THE SWINGARM.....	4-29

CHAIN DRIVE	4-30
REMOVING THE DRIVE CHAIN	4-30
CHECKING THE DRIVE CHAIN.....	4-30
CHECKING THE DRIVE SPROCKET.....	4-31
CHECKING THE REAR WHEEL SPROCKET	4-31
INSTALLING THE DRIVE CHAIN.....	4-31

EAM20094

GENERAL CHASSIS

EAM30016

REMOVING THE SEAT

TIP

The sub-seat and the seat are coupled with each other with a plastic band.

When removing the seat, always remove the sub-seat beforehand.

1. Remove:

- Sub-seat "1"
- Refer to "FUEL TANK CAP" on page 1-16.

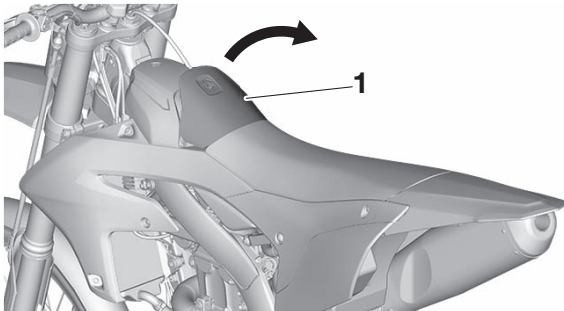

2. Remove:

- Seat "1"

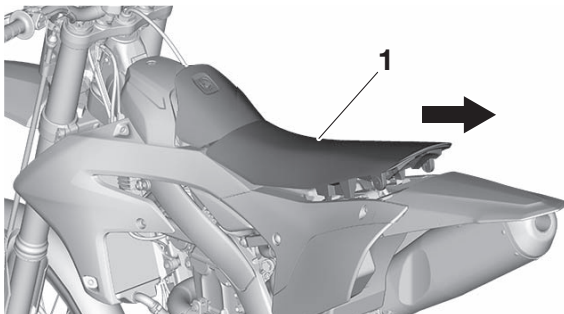

EAM30371

REMOVING THE NUMBER PLATE

1. Remove:

- Bolt (number plate)
- Number plate "1"

TIP

• Remove the brake hose "2" from the upper guide "a" and the lower guide "b" on the number plate.

• The projection "c" on the number plate is inserted into the front fender. Remove the number plate by pulling it off the front fender.

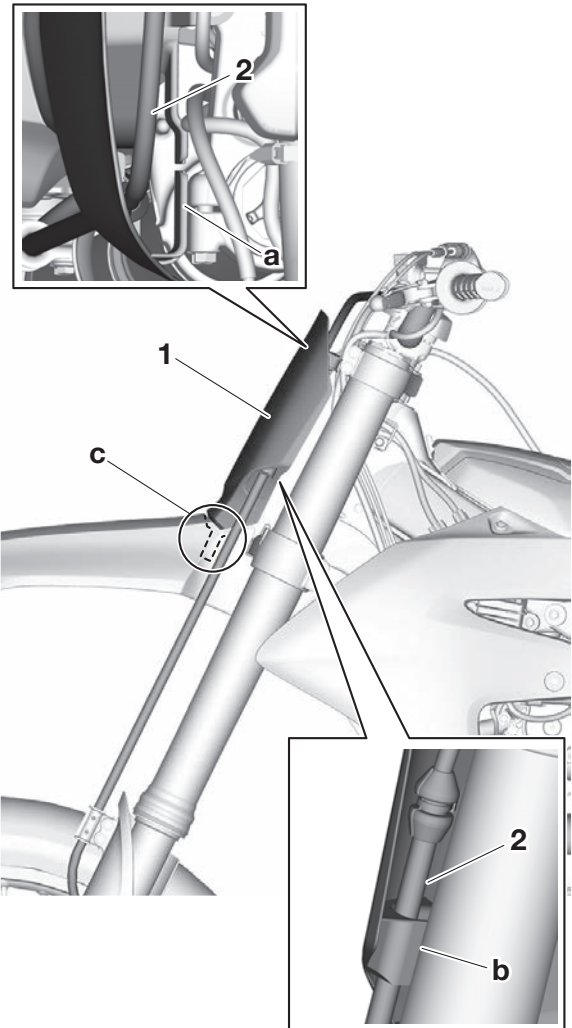

EAM30640

INSTALLING THE SHROUD

1. Install:

- Shroud (left "1"/right)

TIP

Insert the projection "a" on the radiator guard (left/right) into the hole "b" in the shroud (left/right), install the shroud, and then secure it with the bolts.

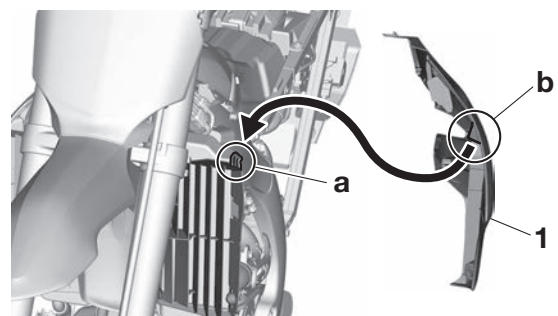

EAM30459

REMOVING THE SIDE COVER

1. Remove:

- Side cover (right) “1”

TIP

Remove the side cover (right) from the vehicle by removing the bolts and sliding it as shown.

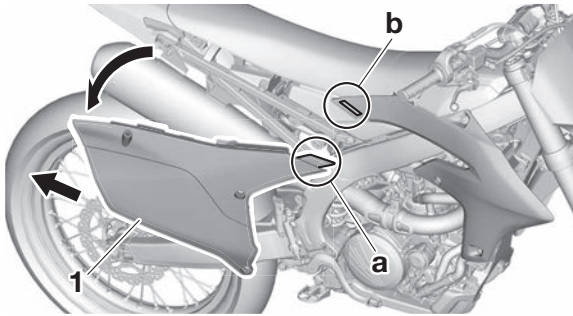

- a. Projection
- b. Slot

EAM30460

INSTALLING THE SIDE COVER

1. Install:

- Side cover (right) “1”

TIP

- Install the side cover (right) by sliding it as shown and secure it with the bolts to fit it to the vehicle.
- Install the side cover (right) so that the rib is located under the rib of the rear fender.

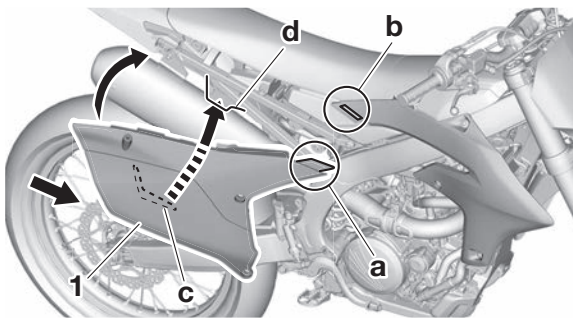

- a. Projection
- b. Slot
- c. Rib (side cover)
- d. Rib (rear fender)

EAM20095

FRONT WHEEL

EAM30017

REMOVING THE FRONT WHEEL

1. Use a maintenance stand to raise the front wheel off the ground.

EWA13120

WARNING

Securely support the vehicle so that there is no danger of it falling over.

2. Remove:
 - Front wheel

EAM30617

INSTALLING THE FRONT WHEEL

1. Install:
 - Front wheel

TIP

Install the brake disc “1” between the brake pads “2” correctly.

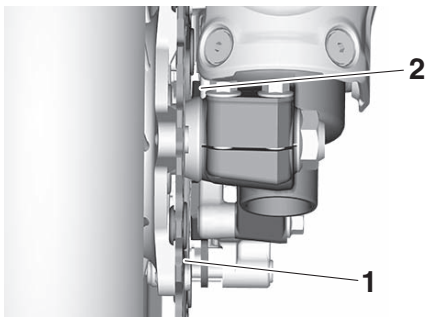

2. Install:
 - Front wheel axle “1”

TIP

Apply the lithium-soap-based grease to the front wheel axle.

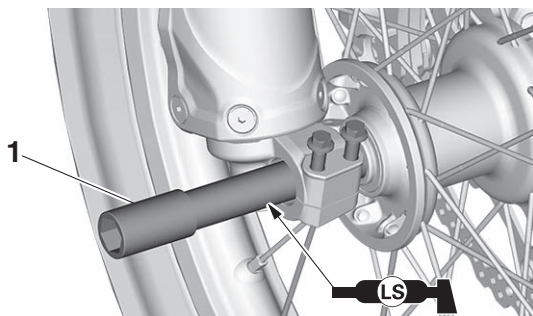

3. Tighten:
 - Front wheel axle nut “1”



Front wheel axle nut
115 N·m (11.5 kgf·m, 85 lb·ft)

ECA24430

NOTICE

Before tightening the front wheel axle nut, push down hard on the handlebar(s) several times and check if the front fork rebounds smoothly.

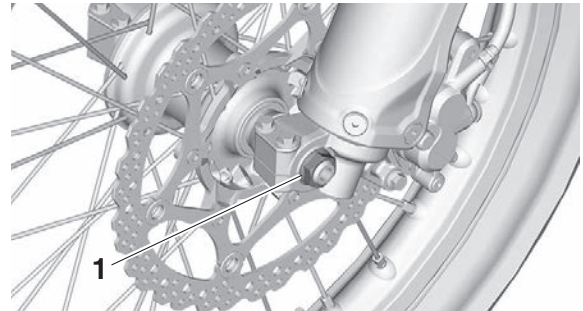

4. Tighten:
 - Front wheel axle pinch bolt “1”



Front wheel axle pinch bolt
21 N·m (2.1 kgf·m, 15 lb·ft)



EAM20096

REAR WHEEL

EAM30022

REMOVING THE REAR WHEEL

1. Use a maintenance stand to raise the rear wheel off the ground.

EWA13120

WARNING

Securely support the vehicle so that there is no danger of it falling over.

2. Remove:
 - Rear wheel axle nut "1"
3. Loosen:
 - Locknut "2"
4. Tighten:
 - Adjusting bolt "3"

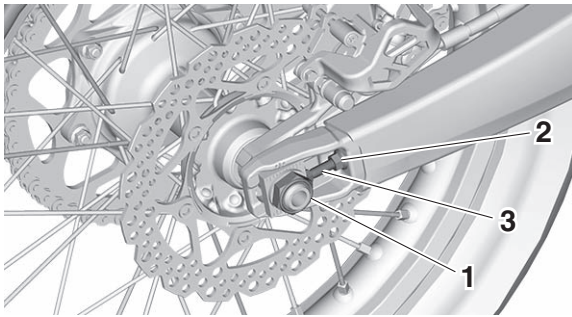

5. Remove:
 - Rear wheel axle
 - Rear wheel

TIP

- Push the rear wheel forward and remove the drive chain from the rear wheel sprocket.
- Do not depress the brake pedal with the rear wheel removed.

EAM30025

CHECKING AND REPLACING THE REAR WHEEL SPROCKET

1. Check:
 - Rear wheel sprocket
 - More than 1/4 tooth wear "a" → Replace the rear wheel sprocket and the drive sprocket as a set.
 - Bent tooth → Replace the rear wheel sprocket and the drive sprocket as a set.

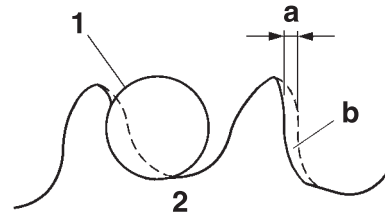

- b. Correct
 1. Drive chain roller
 2. Rear wheel sprocket

2. Replace:
 - Rear wheel sprocket
 - a. Remove the self-locking nuts and the rear wheel sprocket.
 - b. Clean the rear wheel drive hub with a clean cloth, especially the surfaces that contact the sprocket.
 - c. Install the new rear wheel sprocket.



Rear wheel sprocket self-locking nut
42 N·m (4.2 kgf·m, 31 lb·ft)

TIP

Tighten the self-locking nuts in stages and in a crisscross pattern.

EAM30027

INSTALLING THE REAR WHEEL

1. Install:
 - Rear wheel

TIP

Install the brake disc "1" between the brake pads "2" correctly.

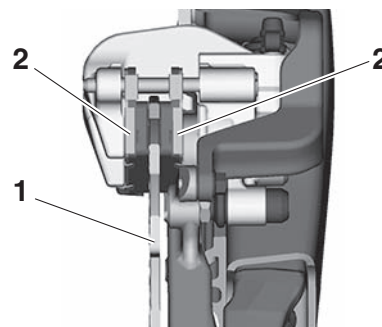

2. Install:
 - Drive chain "1"

TIP

Push the rear wheel "2" forward and install the

REAR WHEEL

drive chain.

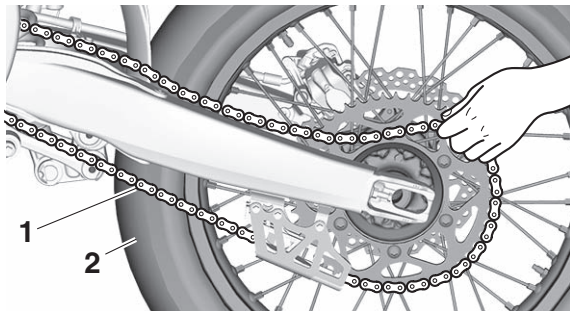

3. Install:

- Drive chain puller (left) "1"
- Rear wheel axle "2"

TIP

- Install the drive chain puller (left), and insert the rear wheel axle from the left side.
- Apply the lithium-soap-based grease to the rear wheel axle.

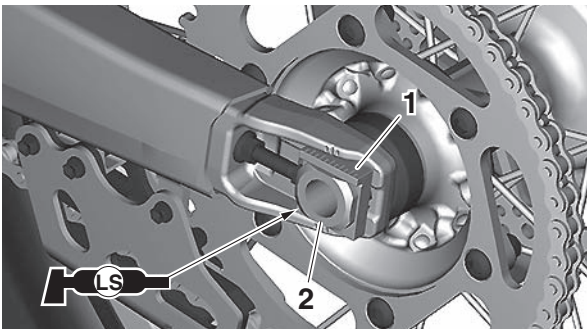

4. Install:

- Drive chain puller (right) "1"
- Washer "2"
- Rear wheel axle nut "3"

TIP

Temporarily tighten the rear wheel axle nut at this point.

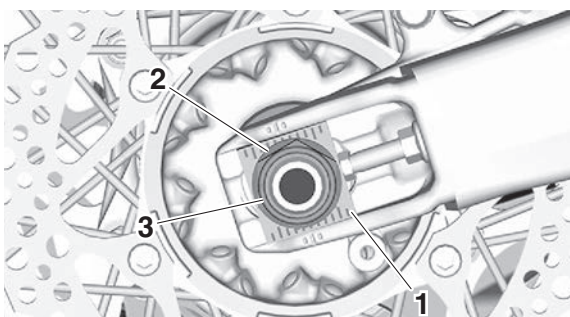

5. Adjust:

- Drive chain slack "a"



Drive chain slack (Maintenance Stand)
50.0–60.0 mm (1.97–2.36 in)

Refer to "DRIVE CHAIN SLACK" on page 3-23.

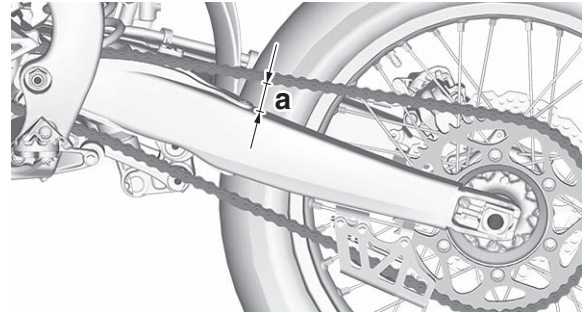

6. Tighten:

- Rear wheel axle nut "1"



Rear wheel axle nut
135 N·m (13.5 kgf·m, 100 lb·ft)

- Locknut "2"



Locknut
21 N·m (2.1 kgf·m, 15 lb·ft)

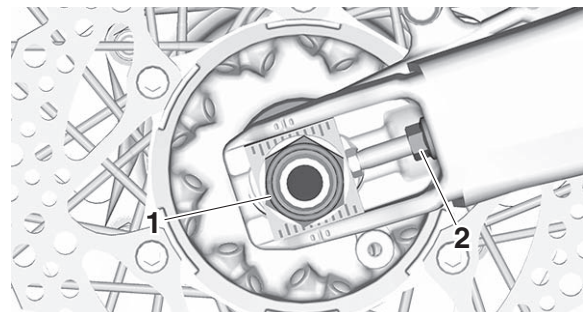

EAM20097

FRONT BRAKE

EAM30519

REPLACING THE FRONT BRAKE PADS

TIP

When replacing the brake pads, it is not necessary to disconnect the brake hose or disassemble the brake caliper.

1. Remove:

- Brake pad
 - a. Remove the pad pin plug "1".

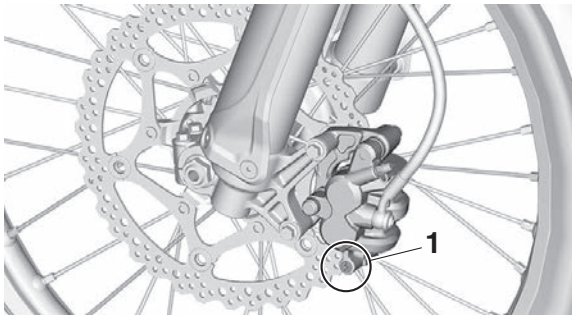

- b. Loosen the pad pin "2".
- c. Remove the brake caliper "3" from the front fork.

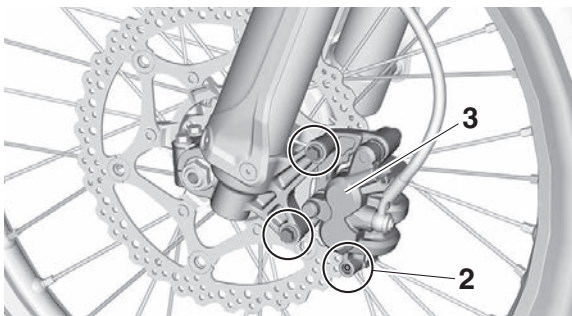

- d. Remove the pad pin and brake pads "4".

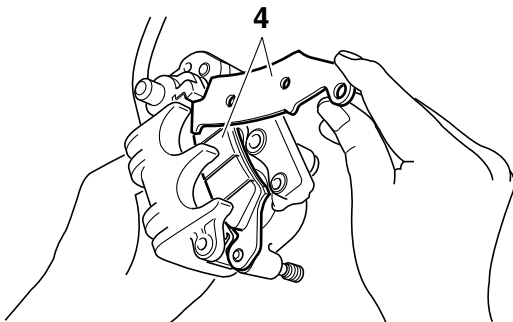

2. Measure:

- Brake pad wear limit "a"
Out of specification → Replace the brake pads as a set.



**Brake pad lining thickness limit
1.0 mm (0.04 in)**

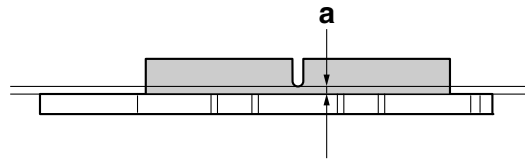

3. Install:

- Brake pad
 - a. Connect the plastic hose "1" to the bleed screw "2" and place a container under the end of the plastic hose.
 - b. Loosen the bleed screw and push the brake caliper piston in.

EWA19160

⚠ WARNING

Do not reuse the drained brake fluid.

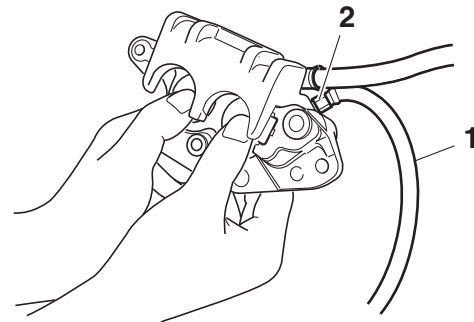

- c. Tighten the bleed screw.



**Bleed screw
5 N·m (0.5 kgf·m, 3.7 lb-ft)**

- d. Install the brake pads "3" and the pad pin.

TIP

- Install the brake pads with their projections "a" into the brake caliper recesses "b".
- Temporarily tighten the pad pin at this point.

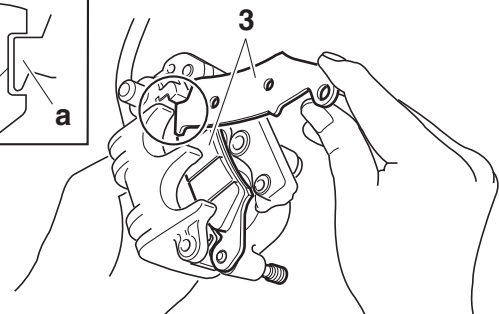
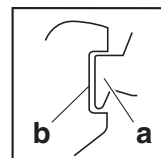

- e. Install the brake caliper "4" and tighten the pad pin "5".



Front brake caliper bolt
28 N·m (2.8 kgf·m, 21 lb·ft)
Pad pin
17 N·m (1.7 kgf·m, 13 lb·ft)

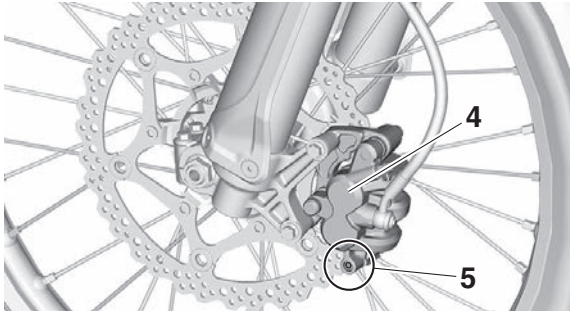

f. Install the pad pin plug “6”.



Pad pin plug
2.5 N·m (0.25 kgf·m, 1.8 lb·ft)

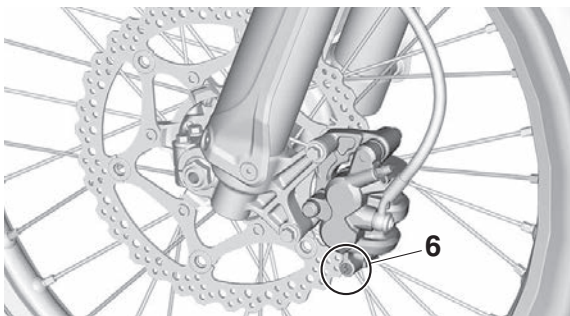

4. Check:
- Brake fluid level
Refer to “CHECKING THE BRAKE FLUID LEVEL” on page 3-20.
5. Check:
- Brake lever operation
A softy or spongy feeling → Bleed the brake system.
Refer to “BLEEDING THE HYDRAULIC BRAKE SYSTEM” on page 3-22.

EAM20098

REAR BRAKE

EAM30523

REPLACING THE REAR BRAKE PADS

TIP

When replacing the brake pads, it is not necessary to disconnect the brake hose or disassemble the brake caliper.

1. Remove:

- Brake pad
 - a. Remove the protector "1" and the pad pin plug "2".

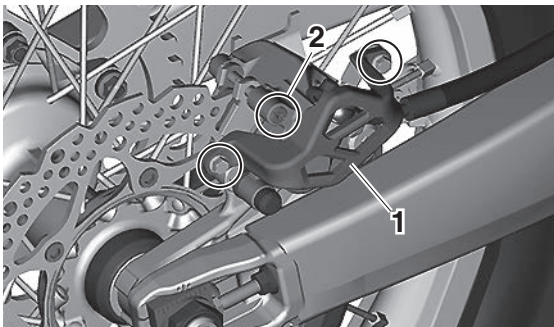

- b. Loosen the pad pin "3".
- c. Remove the rear wheel "4" and the brake caliper "5".

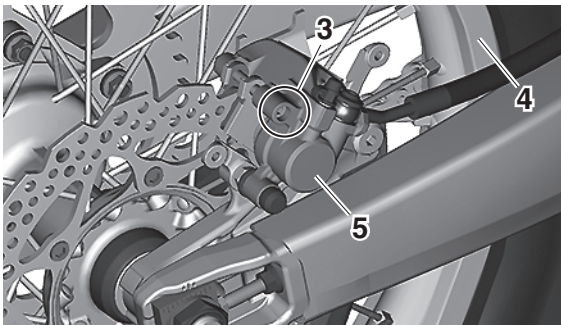

- d. Remove the pad pin "6" and the brake pads "7".

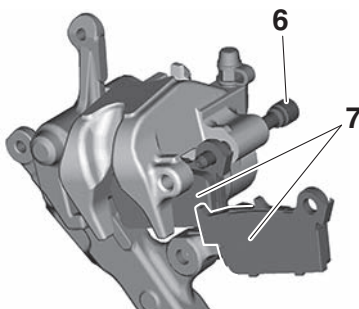

2. Measure:

- Brake pad wear limit "a"
Out of specification → Replace the brake pads as a set.



**Brake pad lining thickness limit
1.0 mm (0.04 in)**

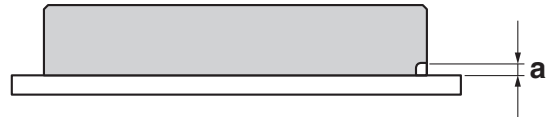

3. Install:

- Brake pad
 - a. Connect the plastic hose "1" to the bleed screw "2" and place a container under the end of the plastic hose.
 - b. Loosen the bleed screw and push the brake caliper piston in.

EWA19170

⚠ WARNING

Do not reuse the drained brake fluid.

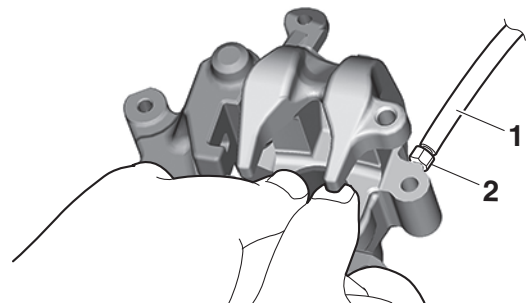

- c. Tighten the bleed screw.



**Bleed screw
5 N·m (0.5 kgf·m, 3.7 lb·ft)**

- d. Install the brake pads "3" and the pad pin "4".

TIP

- Install the brake pads with their projections "a" into the brake caliper recesses "b".
- Temporarily tighten the pad pin at this point.

REAR BRAKE

Refer to “BLEEDING THE HYDRAULIC BRAKE SYSTEM” on page 3-22.

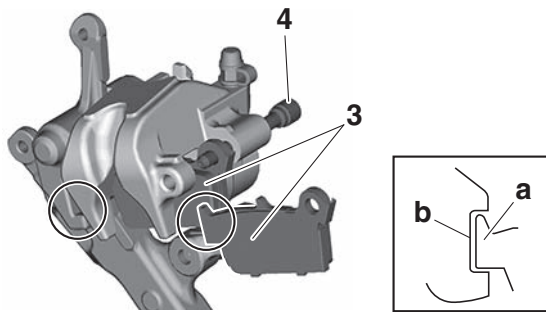

- e. Install the brake caliper “5” and the rear wheel “6”.
- f. Tighten the pad pin “7”.



Pad pin
17 N·m (1.7 kgf·m, 13 lb·ft)

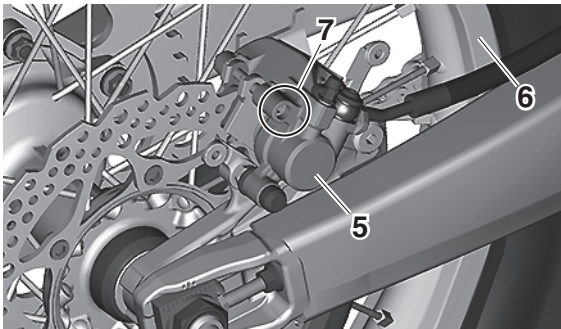

- g. Install the pad pin plug “8” and the protector “9”.



Pad pin plug
2.5 N·m (0.25 kgf·m, 1.8 lb·ft)
Rear brake caliper protector bolt
7 N·m (0.7 kgf·m, 5.2 lb·ft)

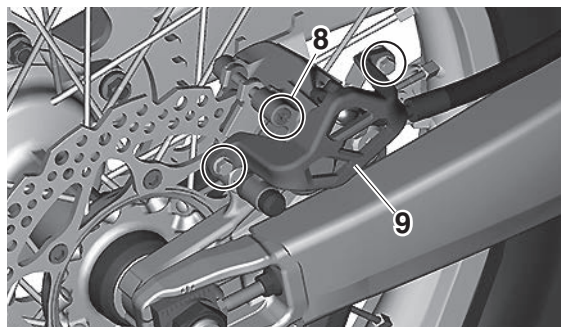

4. Check:
 - Brake fluid level
Refer to “CHECKING THE BRAKE FLUID LEVEL” on page 3-20.
5. Check:
 - Brake pedal operation
A soft or spongy feeling → Bleed the brake system.

EAM20099

HANDLEBAR

EAM30052

REMOVING THE HANDLEBAR

1. Stand the vehicle upright on a level surface.

EWA13120

WARNING

Securely support the vehicle so that there is no danger of it falling over.

2. Remove:

- Grip "1"

TIP

Blow in compressed air between the handlebar or tube guide and the grip. Then remove the grip which has become loose.

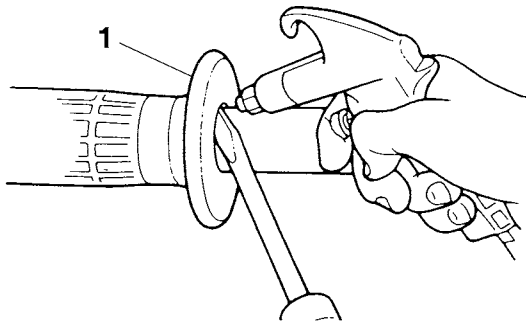

3. Remove:

- Throttle cable housing "1"
- Throttle grip "2"

TIP

While removing the throttle cable housing, pull back the rubber cover "3".

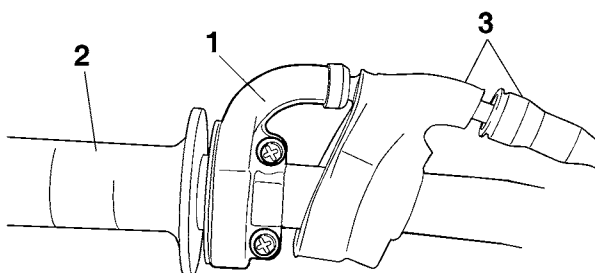

EAM30053

CHECKING THE HANDLEBAR

1. Check:

- Handlebar
Bends/cracks/damage → Replace.

EWA13690

WARNING

Do not attempt to straighten a bent handlebar as this may dangerously weaken it.

EAM30054

INSTALLING THE HANDLEBAR

1. Stand the vehicle upright on a level surface.

EWA13120

WARNING

Securely support the vehicle so that there is no danger of it falling over.

2. Install:

- Damper "1"
- Lower handlebar holder "2" (temporarily)
- Handlebar "3"
- Upper handlebar holder "4"



**Upper handlebar holder bolt
28 N·m (2.8 kgf·m, 21 lb·ft)**

TIP

- Install the lower handlebar holders with the side having the longer distance "a" from the mounting bolt center facing towards the front side of the vehicle.
- Installing the lower handlebar holders in the reverse direction allow the front-to-rear offset amount of the handlebar position to be changed.
- Installing the lower handlebar holder holes from the back to the front allows front-to-rear offset amount of the handlebar position to be changed.
- When installing the dampers and the lower handlebar holders in the front hole, be sure to route the handlebar switch lead (left) "5" as shown in the illustration.
- The upper handlebar holders should be installed with the punch marks "b" facing forward.
- When installing the handlebar, make sure that right and left marks "c" are in place identically on both sides.
- Install the handlebar so that the projection "d" of the upper handlebar holders is positioned at the mark on the handlebar as shown.

ECA14250

NOTICE

- **First, tighten the bolts on the front side of the handlebar holder, and then on the rear side.**
- **Turn the handlebar all the way to the left and right. If there is any contact with the fuel tank, adjust the handlebar position.**

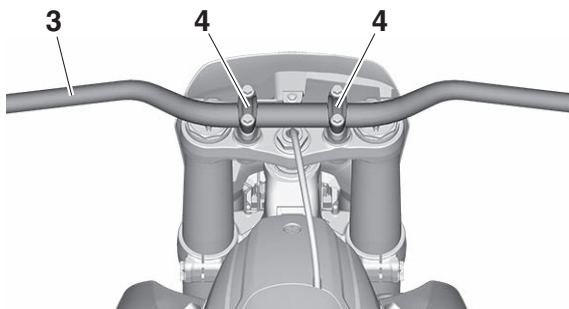
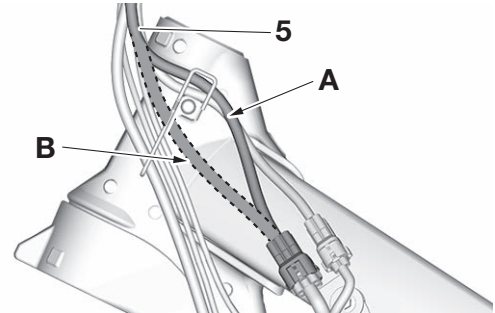
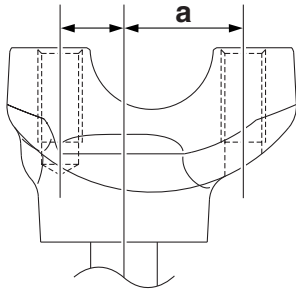
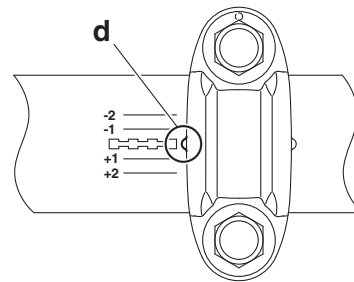
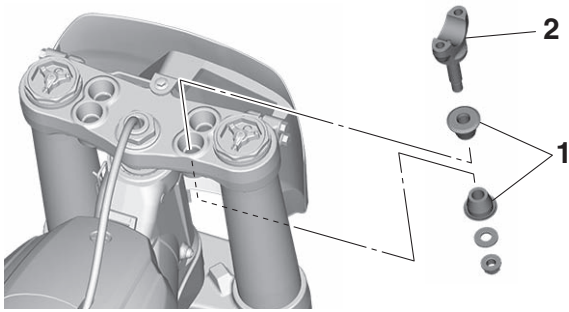

- A. Routing when installing the damper and lower handlebar in the rear holes
 B. Routing when installing the damper and lower handlebar in the front holes

3. Tighten:

- Lower handlebar holder nut



Lower handlebar holder nut
40 N·m (4.0 kgf·m, 30 lb·ft)

4. Install:

- Clutch lever holder "1"
- Clutch lever "2"



Clutch lever holder bolt
5 N·m (0.5 kgf·m, 3.7 lb·ft)
Clutch lever pivot bolt
3.0 N·m (0.30 kgf·m, 2.2 lb·ft)
Clutch lever pivot nut
7 N·m (0.7 kgf·m, 5.2 lb·ft)

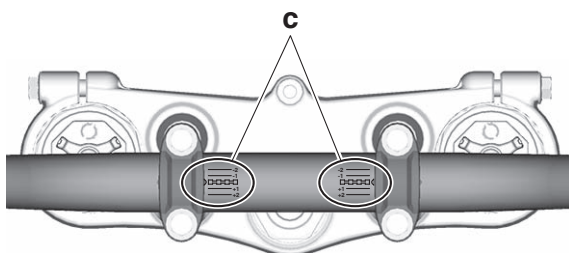
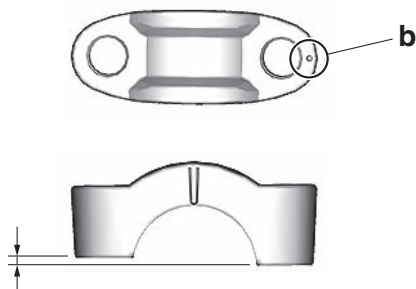

TIP

- After tightening the clutch lever pivot bolt, tighten the clutch lever pivot nut, while holding the clutch lever pivot bolt to prevent it from turning.
- The clutch lever holder "1" should be installed according to the dimensions shown.

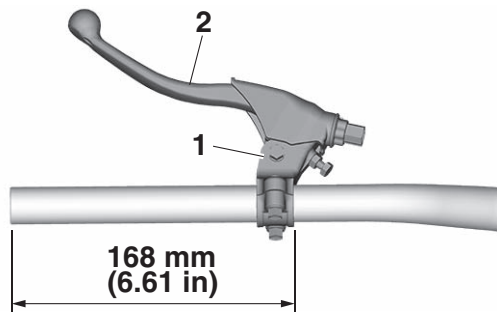

5. Install:
- Handlebar switch (left) "1"
 - Clamp "2"

	Handlebar switch (left) 1.3 N·m (0.13 kgf·m, 0.95 lb·ft)
---	---

- TIP**
- The handlebar switch (left) "1" should be installed according to the dimensions shown.
 - Pass the handlebar switch lead (left) through the middle of the clutch lever holder.

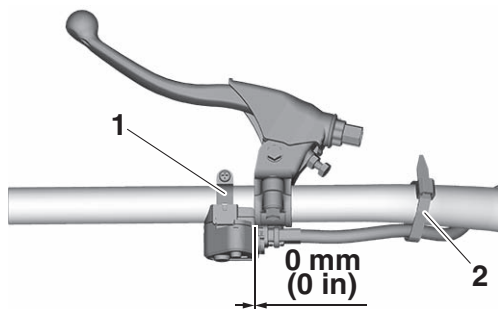

6. Install:
- Handlebar grip (left) "1"
 - Slightly coat the handlebar left end with a rubber adhesive.
 - Install the handlebar grip (left) on the handlebar by pressing the grip from the left side.
 - Wipe off any excess adhesive with a clean cloth.

TIP
Install the handlebar grip (left) to the handlebar so that the line "a" between the two arrow marks faces straight upward.

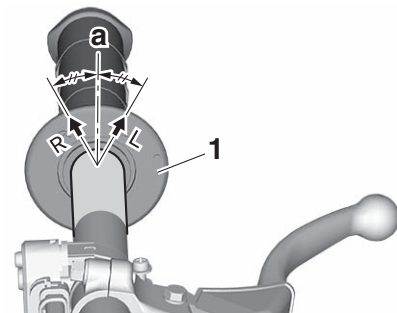

7. Install:
- Clutch cable "1"

TIP
Before installation, apply the lithium-soap-based grease to the clutch cable end.

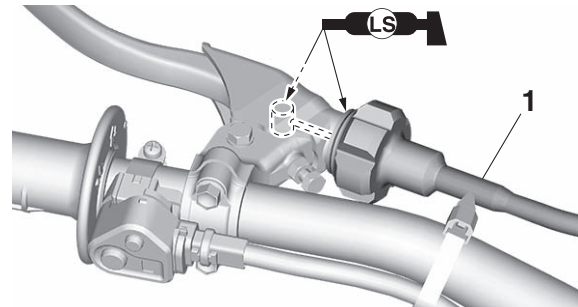

8. Adjust:
- Clutch lever free play
Refer to "ADJUSTING THE CLUTCH LEVER FREE PLAY" on page 3-11.

	Clutch lever free play 7.0–12.0 mm (0.28–0.47 in)
---	--

9. Install:
- Handlebar grip (right) "1"
 - Collar "2"
- Apply adhesive to the tube guide "3".

TIP

- Before applying the adhesive, wipe off grease or oil on the tube guide surface "a" with a lacquer thinner.
- Install the grip to the tube guide so that the grip match mark "b" and tube guide slot "c" form the angle as shown.

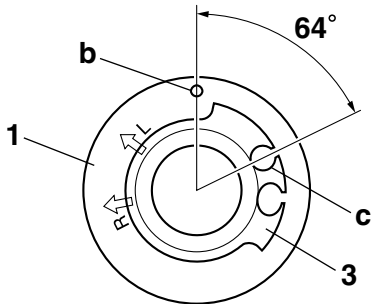
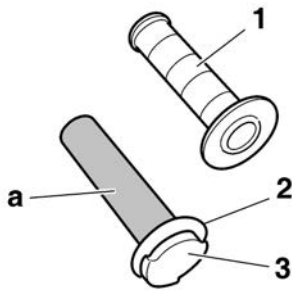

10. Install:

- Rubber cover "1"
- Throttle grip "2"

TIP

Apply the lithium-soap-based grease on the throttle grip sliding surface.

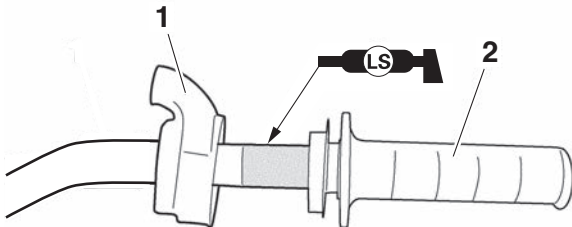

11. Install:

- Throttle cable "1"

TIP

Slightly coat the end of throttle cable and inside of throttle grip with lithium-soap-based grease. Then, mount the throttle grip onto the handlebar.

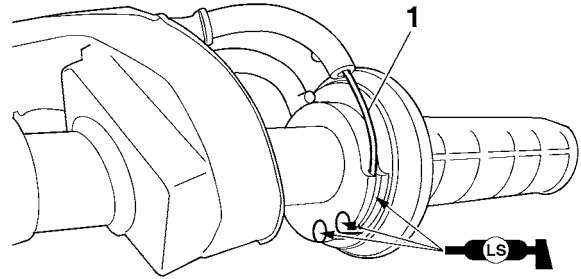

12. Install:

- Throttle cable housing "1"
- Screw (throttle cable housing) "2"



**Screw (throttle cable housing)
3.8 N·m (0.38 kgf·m, 2.8 lb·ft)**

EWA19310

WARNING

After tightening the throttle cable housing screws, check that the throttle grip "3" moves smoothly. If it does not, retighten the screws for adjustment.

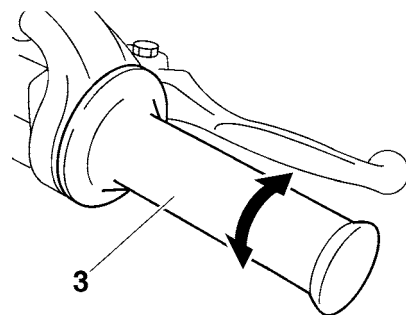
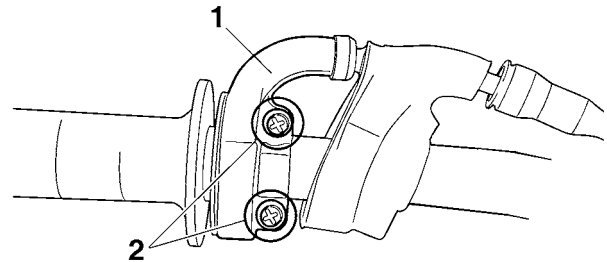

13. Install:

- Rubber cover "1"
- Cover (throttle cable housing) "2"

Refer to "CHECKING THE THROTTLE GRIP" on page 3-8.

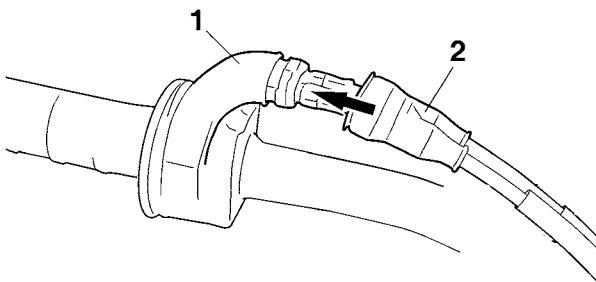

Throttle grip free play
3.0–6.0 mm (0.12–0.24 in)

14. Install:

- Start switch "1"
- Front brake master cylinder assembly "2"
- Front brake master cylinder holder "3"
- Front brake master cylinder holder bolt "4"
- Clamp "5"



Front brake master cylinder holder bolt
9 N·m (0.9 kgf·m, 6.6 lb·ft)

TIP

- Install the front brake master cylinder holder with the "UP" mark facing up.
- Install in order for the top of the front brake master cylinder assembly to be level.
- First, tighten the upper bolt, then the lower bolt.
- Pass the start switch lead through the middle of the front brake master cylinder holder.

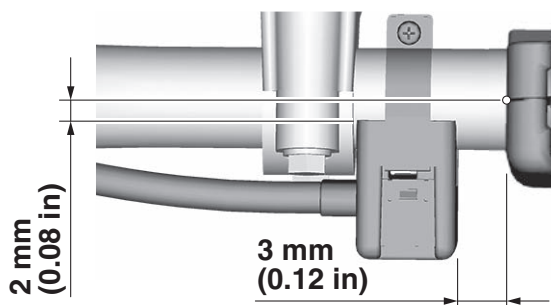
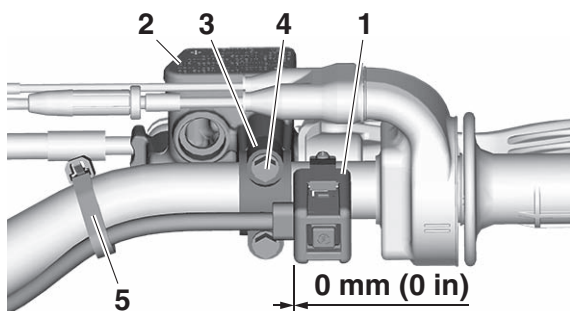

15. Adjust:

- Throttle grip free play

EAM20100

FRONT FORK

EAM30055

REMOVING THE FRONT FORK LEGS

1. Use a maintenance stand to raise the front wheel off the ground.

EWA13120

WARNING

Securely support the vehicle so that there is no danger of it falling over.

TIP

Record the adjusting screw setting position before loosening the adjuster and the base valve.

2. Loosen:

- Upper bracket pinch bolt
- Damper assembly
- Lower bracket pinch bolt

EWA20350

WARNING

Before loosening the upper and lower bracket pinch bolts, support the front fork leg.

TIP

Before removing the front fork leg from the vehicle, loosen the damper assembly "1" with the cap bolt ring wrench "2".



Cap bolt ring wrench
90890-01501
Cap bolt ring wrench
YM-01501

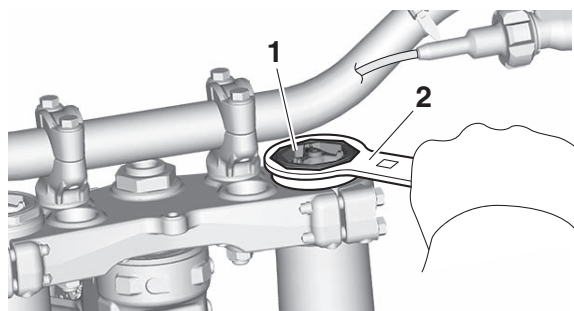

3. Remove:

- Front fork leg

EAM30056

DISASSEMBLING THE FRONT FORK LEGS

1. Drain:

- Fork oil

2. Remove:

- Adjuster "1"
(from the inner tube)

TIP

- While compressing the inner tube "2", set the

cap bolt ring wrench "4" between the inner tube and locknut "3".

- Hold the locknut and remove the adjuster.

ECA24520

NOTICE

Do not remove the locknut as the damper rod may go into the damper assembly and not be taken out.



Cap bolt ring wrench
90890-01501
Cap bolt ring wrench
YM-01501

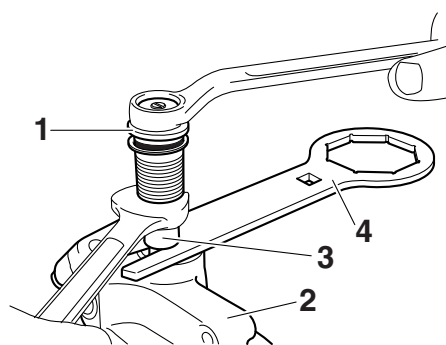

3. Remove:

- Dust seal "1"
- Stopper ring "2"
(with a flat-head screwdriver)

ECA14180

NOTICE

Do not scratch the inner tube.

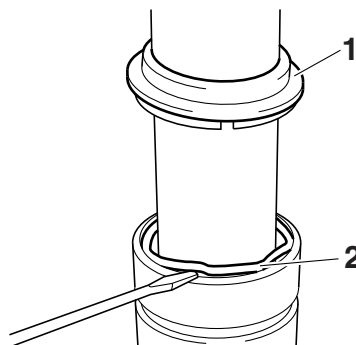

4. Remove:

- Inner tube "1"
 - a. Push in slowly "a" the inner tube just before it bottoms out and then pull it back quickly "b".
 - b. Repeat this step until the inner tube can be pulled out from the outer tube.

FRONT FORK

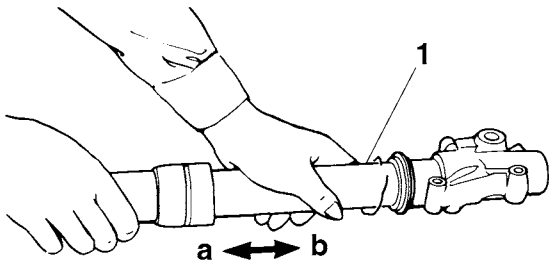

5. Remove:

- Adjuster knob
- Base valve "1"
(from the damper assembly)

TIP

- Before loosening the damping force adjuster, record the setting position.
- Unless the damping force adjuster is fully loosened, correct damping characteristic cannot be obtained after installation.
- Hold the damper assembly with the cap bolt ring wrench "2" and use the cap bolt wrench "3" to remove the base valve.



Cap bolt wrench
90890-01911
Cap bolt ring wrench
90890-01501
Cap bolt ring wrench
YM-01501

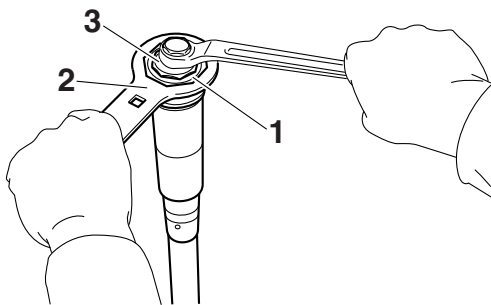

EAM30057

CHECKING THE FRONT FORK LEGS

1. Check:

- Inner tube surface
Scratches → Repair or replace.
Use #1000 grit wet sandpaper.
Damaged oil lock piece → Replace.
- Inner tube bends
Out of specification → Replace.
Use the dial gauge.



Inner tube bending limit
0.2 mm (0.01 in)

TIP

The bending value is shown by one half of the dial gauge reading.

EWA13650

WARNING

Do not attempt to straighten a bent inner tube as this may dangerously weaken it.

2. Check:

- Outer tube
Scratches/wear/damage → Replace.

3. Measure:

- Fork spring free length "a"
Out of specification → Replace.



Fork spring free length limit
492.0 mm (19.37 in)

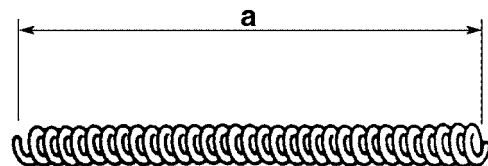

4. Check:

- Damper assembly "1"
Bend/damage → Replace.
- O-ring "2"
Wear/damage → Replace.

ECA14200

NOTICE

- The front fork leg has a built-in damper adjusting rod and a very sophisticated internal construction, which are particularly sensitive to foreign material.
- When disassembling and assembling the front fork leg, do not allow any foreign material to enter the front fork.

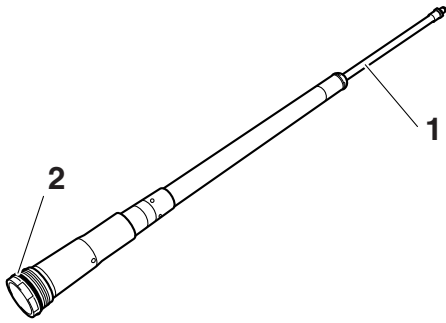

5. Check:

- Base valve “1”
Wear/damage → Replace.
Contamination → Clean.
- O-ring “2”
Wear/damage → Replace.
- Base valve bushing
Wear/damage → Replace.
- Fork spring “3”
Damage/fatigue → Replace the base valve.
- Bleed screw “4”
Wear/damage → Replace.

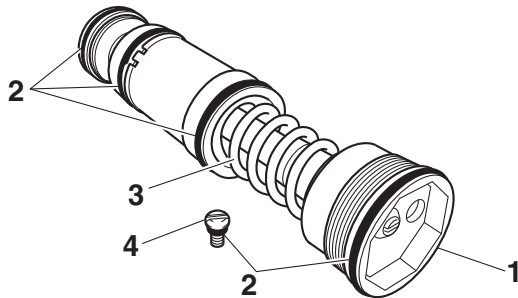

6. Check:

- Upper spring seat “1”
(contacting surface “a”)
Wear/damage → Replace.

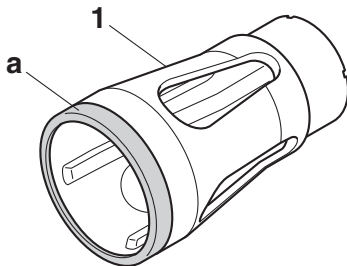

7. Check:

- Adjuster “1”
- O-ring “2”
Wear/damage → Replace.

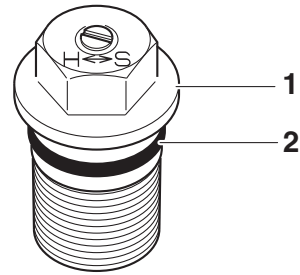

EAM30058

ASSEMBLING THE FRONT FORK LEGS

EWA13660

WARNING

- **Make sure the oil levels in both front fork legs are equal.**
- **Uneven oil levels can result in poor handling and a loss of stability.**

TIP

- When assembling the front fork leg, be sure to replace the following parts:
 - Inner tube bushing
 - Slide metal
 - Oil seal
 - Copper washer
- Before assembling the front fork leg, make sure that all of the components are clean.

1. Stretch the damper assembly fully.
2. Fill:
 - Damper assembly



Recommended oil
Yamaha Suspension Oil S1
Standard oil amount
216 cm³ (7.30 US oz, 7.62 Imp.oz)

ECA24530

NOTICE

- **Be sure to use the recommended oil. Other oils may have an adverse effect on front fork performance.**
- **When disassembling and assembling the front fork leg, take care not to allow any foreign material to enter the front fork.**

3. After filling, pump the damper assembly “1” slowly up and down (about 200 mm (7.9 in) stroke) several times to bleed the damper assembly of air.

TIP

Avoid excessive full stroke. A stroke of 200 mm (7.9 in) or more will cause air to enter. In this

case, repeat the steps (1) to (3).

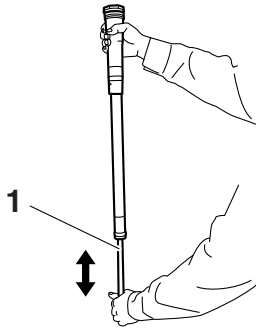

4. Measure:

- Oil level (left and right) “a”
Out of specification → Regulate.



Standard oil level
145–148 mm (5.71–5.83 in)
From top of fully stretched damper assembly.

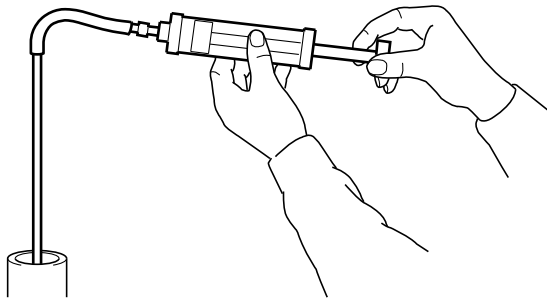
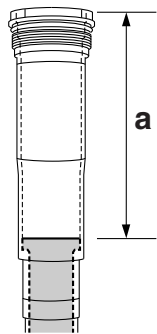

5. Tighten:

- Locknut “1”

TIP

Fully finger tighten the locknut onto the damper assembly.

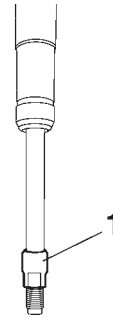

6. Install:

- Base valve “1”
(to the damper assembly “2”)

TIP

First bring the damper rod pressure to a maximum. Then install the base valve while releasing the damper rod pressure.

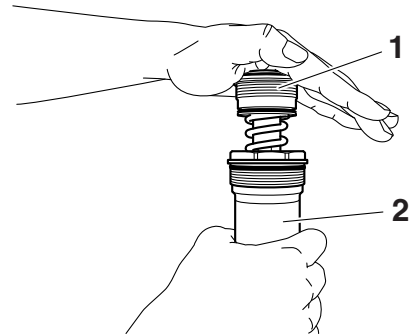

7. Check:

- Damper assembly
Not fully stretched → Repeat the steps (1) to (7).

8. Tighten:

- Base valve “1”
- Screw (adjuster knob)



Base valve
28 N·m (2.8 kgf·m, 21 lb·ft)
Screw (adjuster knob)
0.6 N·m (0.06 kgf·m, 0.44 lb·ft)

TIP

Hold the damper assembly with the cap bolt ring wrench “2” and use the cap bolt wrench “3” to tighten the base valve.



Cap bolt wrench
90890-01911
Cap bolt ring wrench
90890-01501
Cap bolt ring wrench
YM-01501

FRONT FORK

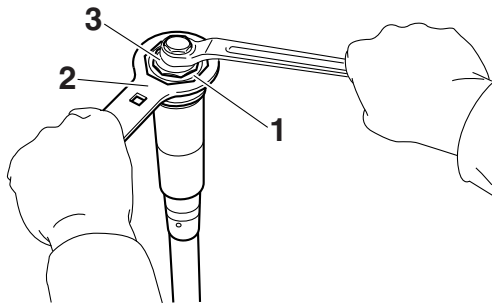

9. After filling, pump the damper assembly “1” slowly up and down more than 10 times to distribute the fork oil.

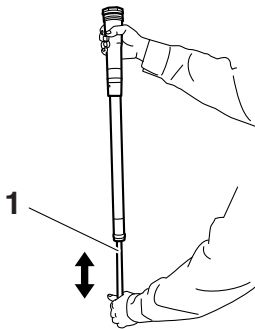

10. While protecting the damper assembly “1” with a cloth and compressing fully, allow excessive oil to overflow on the base valve side.

ECA24540

NOTICE

Take care not to damage the damper assembly.



11. Allow the overflowing oil to escape at the hole “a” in the damper assembly.

TIP

The overflow measures about 10 cm³ (0.34 US oz, 0.35 Imp.oz).

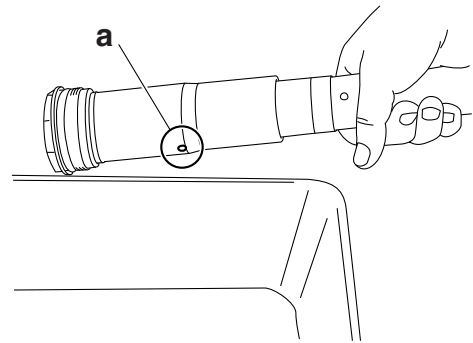

12. Check:

- Damper assembly smooth movement
- Tightness/binding/rough spots → Repeat the steps (1) to (12).

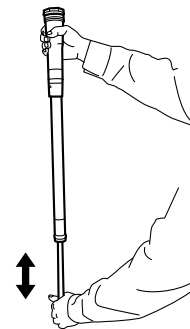

13. Install:

- Dust seal “1” **New**
- Stopper ring “2”
- Oil seal “3” **New**
- Washer “4”
- Slide metal “5” **New** (to the inner tube “6”)

ECA24550

NOTICE

Make sure that the numbered side of the oil seal faces bottom side.

TIP

- Apply the lithium-soap-based grease on the dust seal lip and oil seal lip.
- Apply the fork oil on the inner tube.
- When installing the oil seal, use vinyl seat “a” with fork oil applied to protect the oil seal lip.

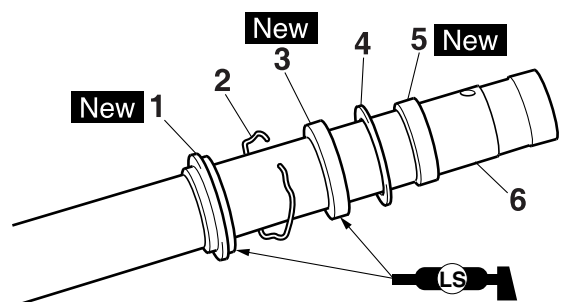

FRONT FORK

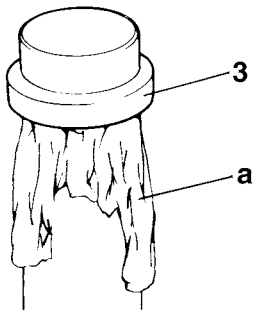

14. Install:

- Piston metal "1" **New**

TIP

Install the piston metal onto the slot on inner tube.

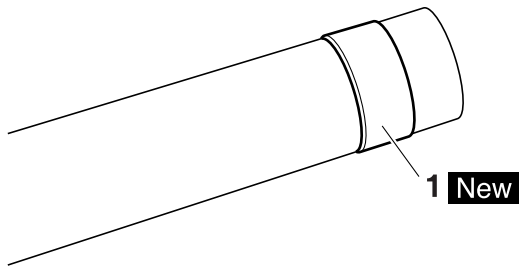

15. Install:

- Outer tube "1"
- (to the inner tube "2")

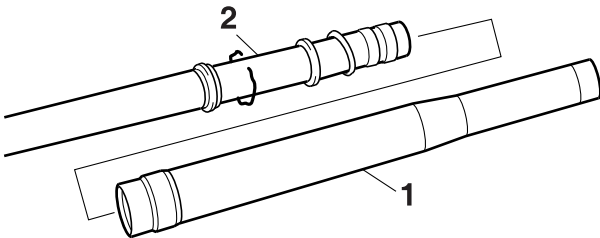

16. Install:

- Slide metal "1" **New**
- Washer "2"
- (to the outer tube)

TIP

Press the slide metal into the outer tube with fork seal driver "3".

	<p>Fork seal driver 90890-01502 Fork seal driver (48) YM-A0948</p>
---	--

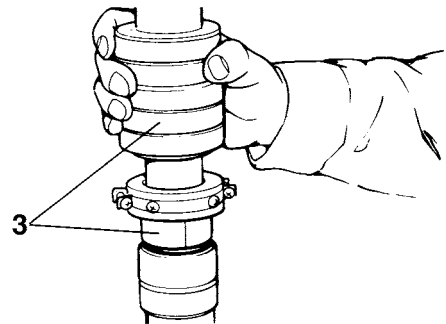
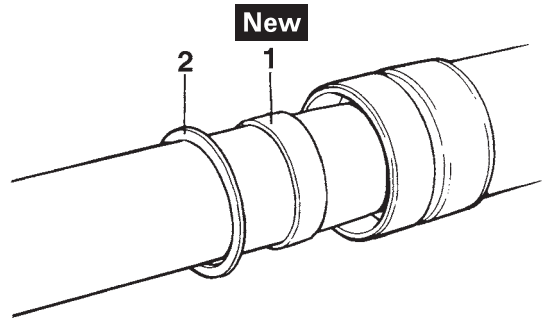

17. Install:

- Oil seal "1" **New**

TIP

Using a fork seal driver "2", press the oil seal in until the stopper ring groove fully appears.

	<p>Fork seal driver 90890-01502 Fork seal driver (48) YM-A0948</p>
---	--

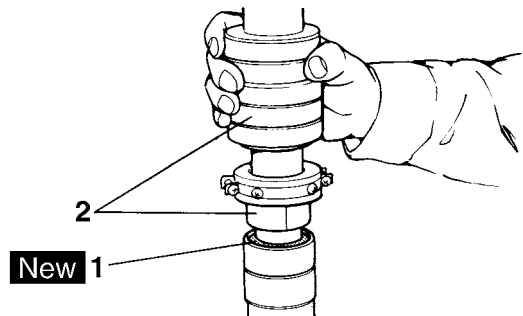

18. Install:

- Stopper ring "1"

TIP

Fit the stopper ring correctly in the groove in the outer tube.

FRONT FORK

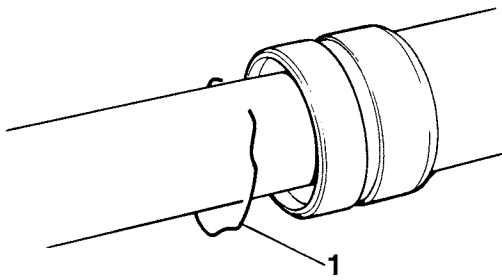

19. Install:

- Dust seal "1" **New**

TIP

Apply lithium-soap-based grease on the inner tube.

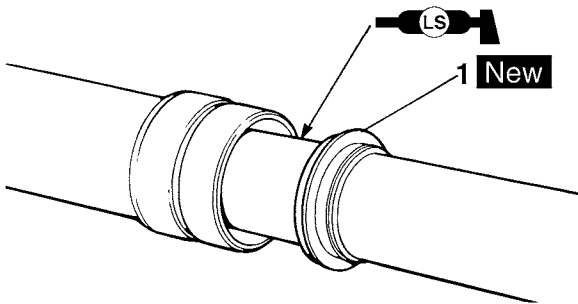

20. Check:

- Inner tube smooth movement
- Tightness/binding/rough spots → Repeat the steps (14) to (20).

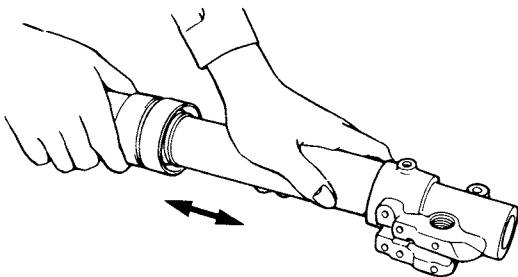

21. Measure:

- Distance "a"
- Out of specification → Turn the locknut to specification.



Distance "a"
16 mm (0.63 in) or more
Between the damper assembly "1" bottom and locknut "2" bottom.

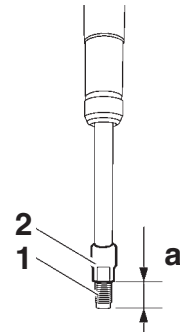

22. Install:

- Upper spring seat "1"
- Fork spring "2"
- (to the damper assembly "3")

TIP

Install the upper spring seat with its larger dia. end "a" facing the fork spring.

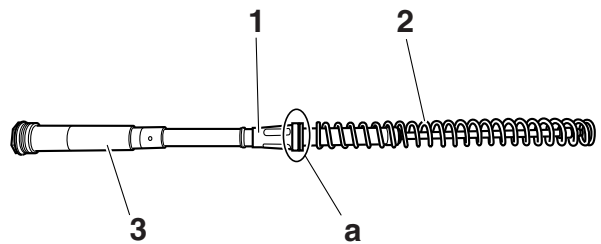

23. Install:

- Damper assembly "1"
- (to the inner tube "2")

ECA24560

NOTICE

Allow the damper assembly to slide slowly down the inner tube until it contacts the bottom of the inner tube. Be careful not to damage the inner tube.

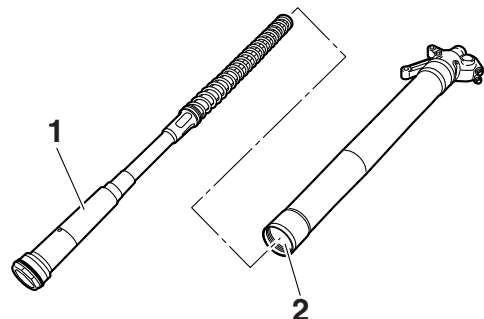

24. Loosen:

- Rebound damping force adjuster "1"

TIP

Before loosening the damping force adjuster, record the setting position.

FRONT FORK

- Unless the damping force adjuster is fully loosened, correct damping characteristic cannot be obtained after installation.

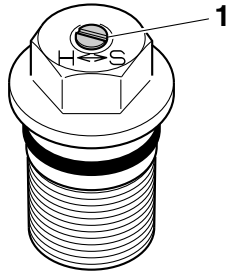

25. Install:

- Damper adjusting rod "1"
 - Copper washer "2" **New**
 - Adjuster "3"
- (to the damper assembly "4")

TIP

- While compressing the inner tube "5", set the cap bolt ring wrench "7" between the inner tube and locknut "6".
- Fully finger tighten the adjuster onto the damper assembly.



**Cap bolt ring wrench
90890-01501
Cap bolt ring wrench
YM-01501**

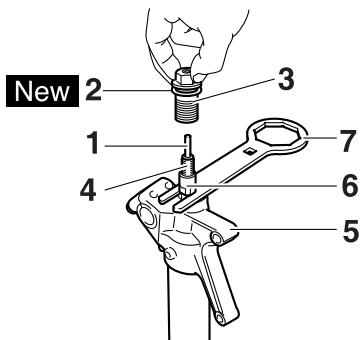

26. Measure:

- Gap "a" between the adjuster "1" and the locknut "2"
- Out of specification → Retighten and readjust the locknut.



**Gap "a" between the adjuster and the locknut
0.5–1.0 mm (0.02–0.04 in)**

TIP

If it is installed with a gap out of specification,

correct damping force cannot be obtained.

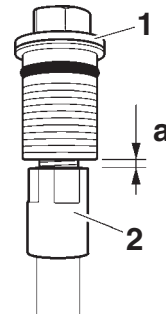

27. Tighten:

- Adjuster (damper assembly) "1"



**Adjuster (damper assembly)
29 N·m (2.9 kgf·m, 21 lb·ft)**

TIP

Hold the locknut "2" and tighten the adjuster.

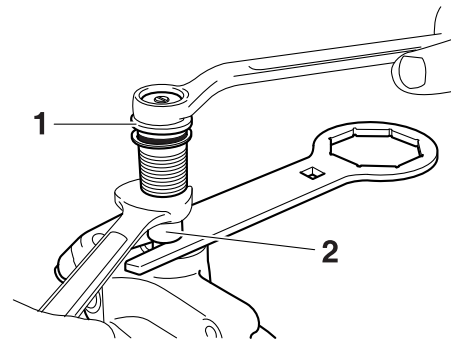

28. Install:

- Adjuster "1"
- (to the inner tube)



**Adjuster
55 N·m (5.5 kgf·m, 41 lb·ft)
LOCTITE®**

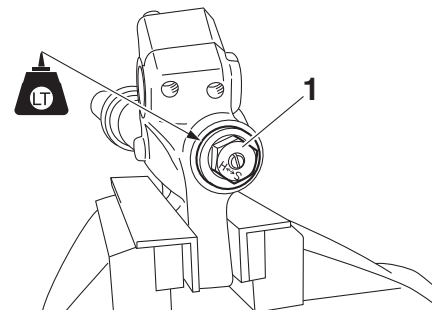

29. Fill:

- Front fork leg

FRONT FORK



Recommended oil
Yamaha Suspension Oil S1
Standard oil amount
280 cm³ (9.47 US oz, 9.88 Imp.oz)
Extent of adjustment
260–365 cm³ (8.79–12.34 US oz, 9.17–12.87 Imp.oz)

ECA24570

NOTICE

- Be sure to use the recommended oil. Other oils may have an adverse effect on front fork performance.
- When disassembling and assembling the front fork leg, do not allow any foreign material to enter the front fork.

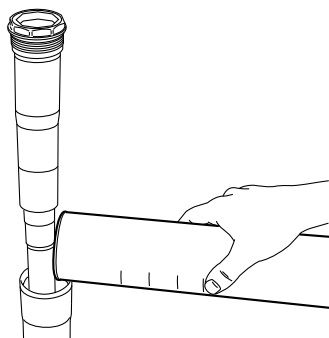

30. Install:

- Damper assembly “1”
(to the outer tube)

TIP

Temporarily tighten the damper assembly.

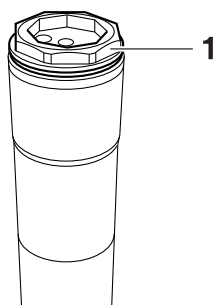

31. Install:

- Protector guide “1”

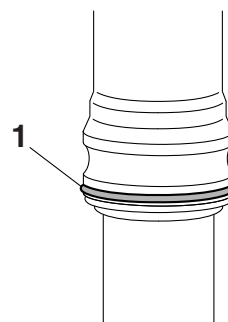

EAM30059

INSTALLING THE FRONT FORK LEGS

1. Install:

- Front fork “1”

TIP

- Temporarily tighten the lower bracket pinch bolts.
- Do not tighten the upper bracket pinch bolts yet.

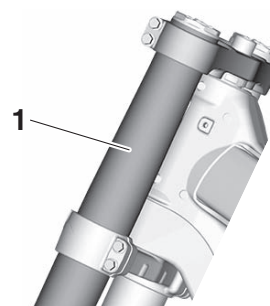

2. Tighten:

- Damper assembly “1”



Damper assembly
30 N·m (3.0 kgf·m, 22 lb·ft)

TIP

Use the cap bolt ring wrench “2” to tighten the damper assembly.



Cap bolt ring wrench
90890-01501
Cap bolt ring wrench
YM-01501

FRONT FORK

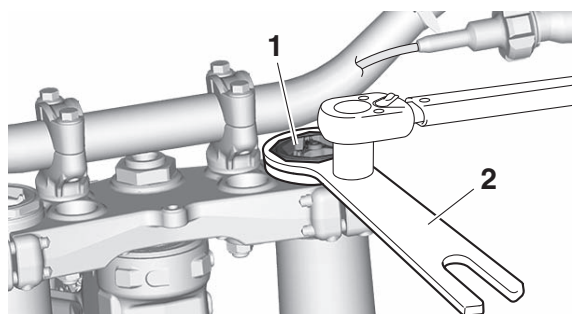

- Front fork protector bolt “2”



**Front fork protector bolt
7 N·m (0.7 kgf·m, 5.2 lb·ft)**

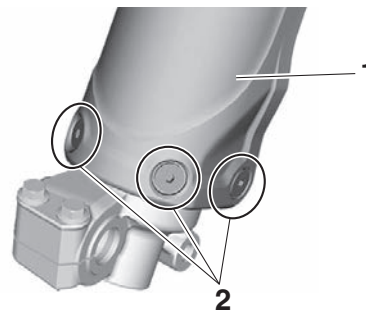

3. Adjust:

- Front fork top end “a”



**Front fork top end (standard) “a”
5 mm (0.2 in)**

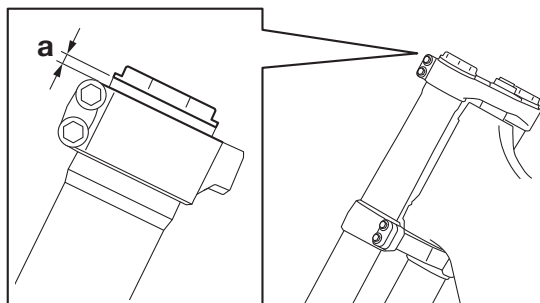

6. Adjust:

- Rebound damping force

TIP

Turn in the damping adjuster “1” finger-tight and then turn out to the originally set position.

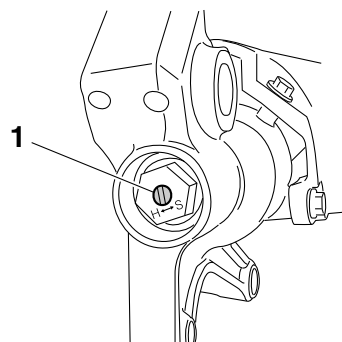

4. Tighten:

- Upper bracket pinch bolt “1”



**Upper bracket pinch bolt
21 N·m (2.1 kgf·m, 15 lb·ft)**

- Lower bracket pinch bolt “2”



**Lower bracket pinch bolt
21 N·m (2.1 kgf·m, 15 lb·ft)**

7. Adjust:

- Compression damping force

TIP

Turn in the damping adjuster “1” finger-tight and then turn out to the originally set position.

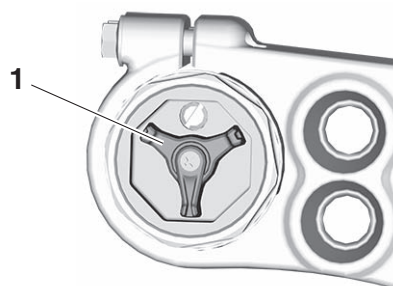

EWA19320

WARNING

Tighten the lower bracket to specified torque. If torqued too much, it may cause the front fork to malfunction.

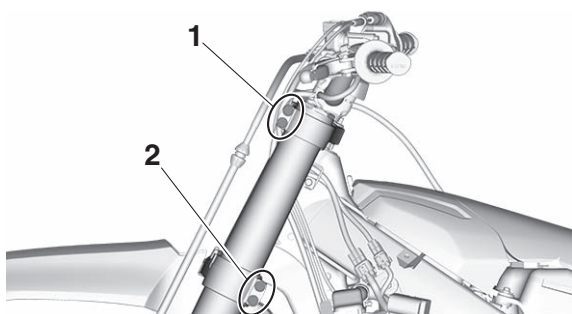

5. Install:

- Protector “1”

EAM20101

STEERING HEAD

EAM30060

REMOVING THE LOWER BRACKET

1. Use a maintenance stand to raise the front wheel off the ground.

EWA13120

WARNING

Securely support the vehicle so that there is no danger of it falling over.

2. Remove:
 - Ring nut "1"

TIP

Remove the ring nut with the steering nut wrench "2".



Steering nut wrench
90890-01403
Exhaust flange nut wrench
YU-A9472

EWA13730

WARNING

Securely support the lower bracket so that there is no danger of it falling.

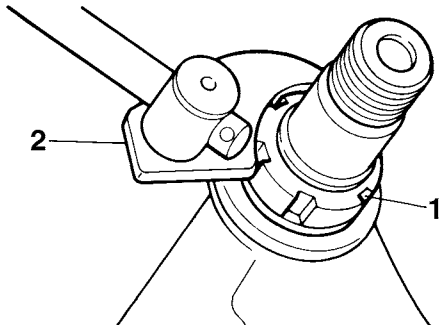

EAM30061

CHECKING THE STEERING HEAD

1. Wash with kerosene:
 - Bearing
 - Bearing race
2. Check:
 - Bearing
 - Bearing race
 Damage/pitting → Replace.
3. Replace:
 - Bearing
 - Bearing race
 - a. Remove the bearing race from the steering head pipe with a long rod "1" and a hammer.
 - b. Remove the bearing race from the lower bracket with a chisel "2" and a hammer.

- c. Install a new bearing race.

ECA14270

NOTICE

If the bearing race is not installed properly, the steering head pipe could be damaged.

TIP

Always replace the bearing and the bearing race as a set.

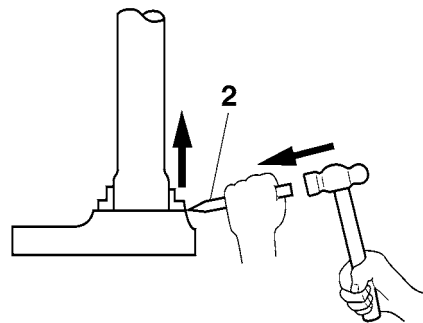
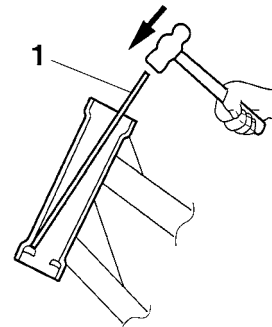

4. Check:
 - Upper bracket
 - Lower bracket
 (along with the steering stem)
Bends/cracks/damage → Replace.

EAM30062

INSTALLING THE STEERING HEAD

1. Install:
 - Lower bearing "1"

TIP

Apply the lithium-soap-based grease on the dust seal lip and bearing inner circumference.

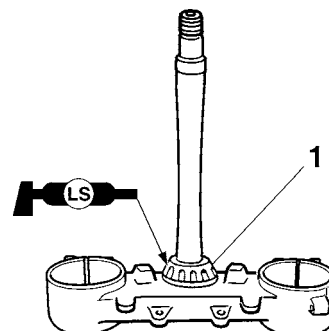

STEERING HEAD

2. Install:

- Bearing race
- Upper bearing "1"
- Bearing race cover "2"

TIP

Apply the lithium-soap-based grease on the bearing and bearing race cover lip.

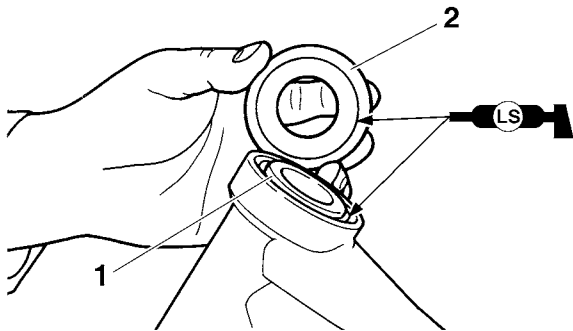

3. Install:

- Lower bracket "1"

TIP

Apply the lithium-soap-based grease on the bearing, the portion "a" and thread of the steering stem.

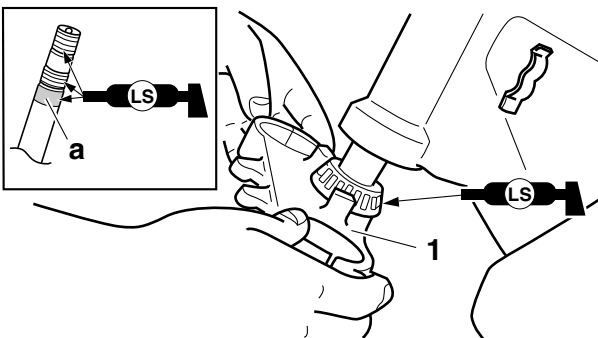

4. Install:

- Steering ring nut "1"



Steering ring nut
7 N·m (0.7 kgf·m, 5.2 lb·ft)

TIP

Install the steering ring nut with its stepped side "a" facing downward.

Tighten the steering ring nut with a steering nut wrench "2".

Refer to "CHECKING AND ADJUSTING THE STEERING HEAD" on page 3-24.

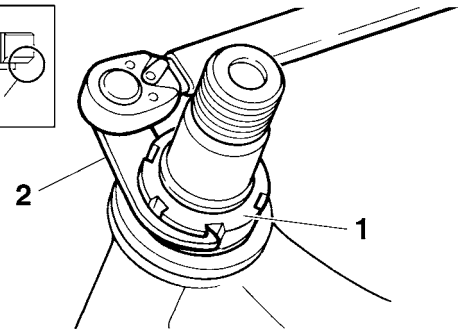
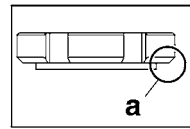

5. Check the steering stem by turning this lock to lock. If there is any binding, remove the steering stem and check the steering bearing.

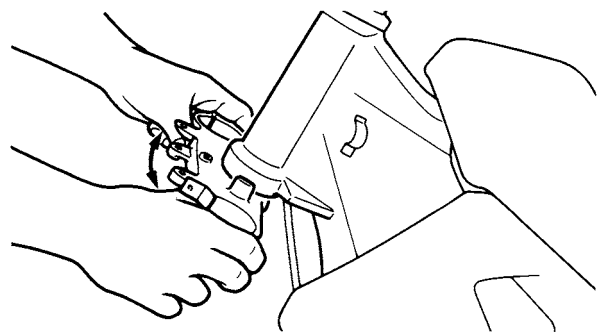

6. Install:

- Washer "1"

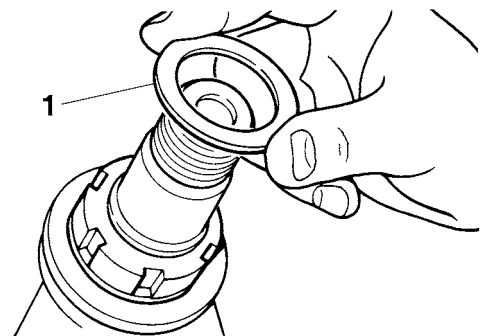

7. Install:

- Front fork "1"
- Upper bracket "2"

TIP

- Temporarily tighten the lower bracket pinch bolts.

- Do not tighten the upper bracket pinch bolts yet.

STEERING HEAD

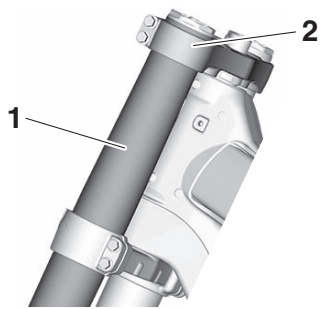

Upper bracket pinch bolt
21 N·m (2.1 kgf·m, 15 lb·ft)

- Lower bracket pinch bolt “2”



Lower bracket pinch bolt
21 N·m (2.1 kgf·m, 15 lb·ft)

EWA19330

⚠ WARNING

Tighten the lower bracket to specified torque. If torqued too much, it may cause the front fork to malfunction.

8. Install:

- Steering stem nut “1”



Steering stem nut
145 N·m (14.5 kgf·m, 107 lb·ft)

TIP

Apply the lithium-soap-based grease to the contact surface of the steering stem nut when installing.

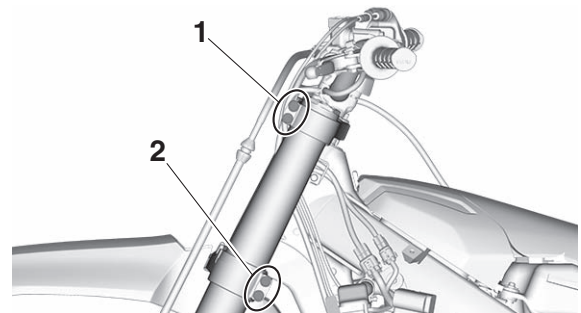
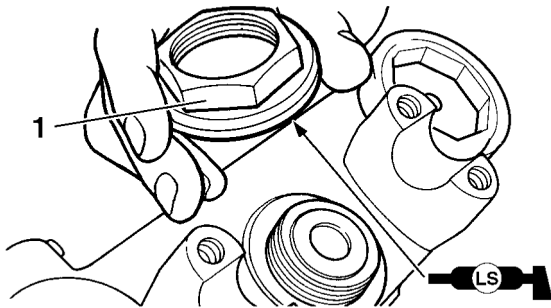

9. After tightening the nut, check the steering for smooth movement. If not, adjust the steering by loosening the steering ring nut little by little.

10. Adjust:

- Front fork top end “a”



Front fork top end (standard) “a”
5 mm (0.2 in)

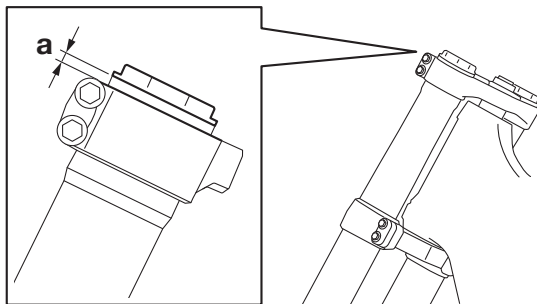

11. Tighten:

- Upper bracket pinch bolt “1”

REAR SHOCK ABSORBER ASSEMBLY

EAM20102

REAR SHOCK ABSORBER ASSEMBLY

EAM30065

REMOVING THE REAR SHOCK ABSORBER ASSEMBLY

1. Use a maintenance stand to raise the rear wheel off the ground.

EWA13120



Securely support the vehicle so that there is no danger of it falling over.

2. Remove:

- Rear shock absorber assembly lower bolt "1"

TIP

While removing the rear shock absorber assembly lower bolt, hold the swingarm so that it does not drop down.

Gas leaks/oil leaks → Replace the rear shock absorber assembly.

- Spring
Damage/wear → Replace.
- Spring guide
Damage/wear → Replace.
- Bearing
Damage/wear → Replace.
- Bolt
Bends/damage/wear → Replace.

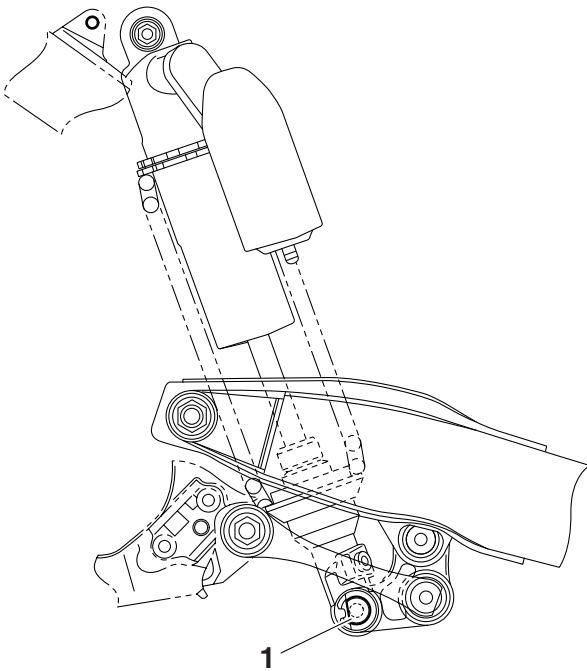

3. Remove:

- Rear shock absorber assembly upper bolt
- Rear shock absorber assembly

EAM30067

CHECKING THE REAR SHOCK ABSORBER ASSEMBLY

1. Check:

- Rear shock absorber rod
Bends/damage → Replace the rear shock absorber assembly.
- Rear shock absorber

EAM20103

SWINGARM

EAM30071

REMOVING THE SWINGARM

1. Use a maintenance stand to raise the rear wheel off the ground.

EWA13120

WARNING

Securely support the vehicle so that there is no danger of it falling over.

2. Measure:
 - Swingarm side play
 - Swingarm vertical movement
 - a. Measure the tightening torque of the pivot shaft nut.

	Pivot shaft nut 85 N·m (8.5 kgf·m, 63 lb·ft)
---	---

- b. Check the swingarm side play “a” by moving the swingarm from side to side. If the swingarm has side-to-side play, check the bushings, the bearings, and the collars.
- c. Check the swingarm vertical movement “b” by moving the swingarm up and down.

If swingarm vertical movement is not smooth or if there is binding, check the bushings, the bearings, and the collars.

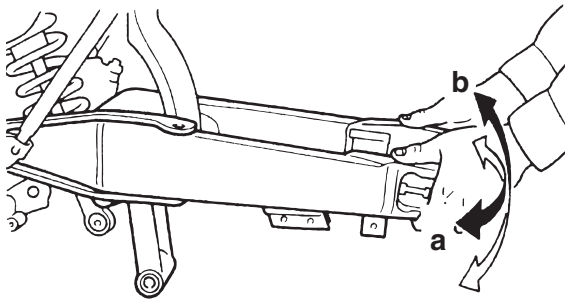

EAM20104

CHAIN DRIVE

EAM30075

REMOVING THE DRIVE CHAIN

1. Stand the vehicle on a level surface.

EWA13120

WARNING

Securely support the vehicle so that there is no danger of it falling over.

2. Remove:

- Master link clip
- Master link "1"
- Master link plate "2"
- Drive chain "3"

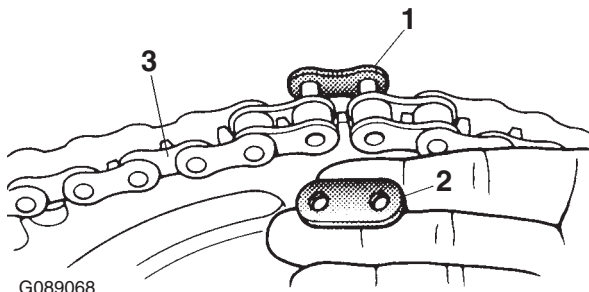

EAM30076

CHECKING THE DRIVE CHAIN

1. Measure:

- 15-link section of the drive chain
- Out of specification → Replace the drive chain.



**15-link length limit
242.9 mm (9.56 in)**

- a. Measure the length "a" between the inner sides of the pins and the length "b" between the outer sides of the pins on a 15-link section of the drive chain as shown in the illustration.

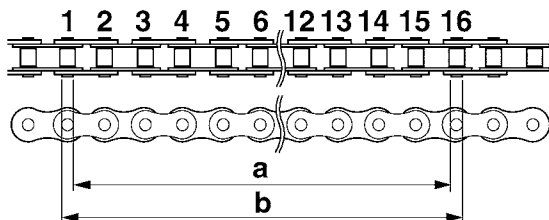

- b. Calculate the length "c" of the 15-link section of the drive chain using the following formula.
Drive chain 15-link section length "c" =

(length "a" between pin inner sides + length "b" between pin outer sides)/2

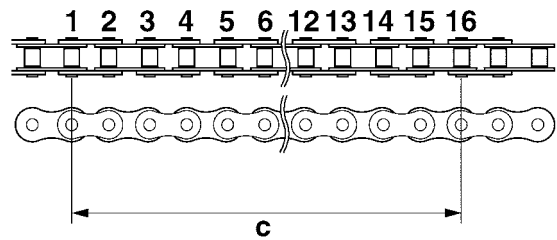

TIP

- When measuring a 15-link section of the drive chain, make sure that the drive chain is taut.
- Perform this procedure 2–3 times, at a different location each time.

2. Check:

- Drive chain
- Stiffness → Clean, lubricate, or replace.

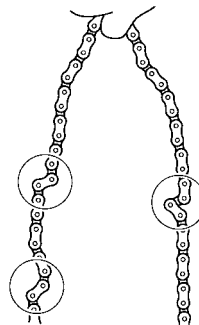

3. Clean:

- Drive chain
 - a. Wipe the drive chain with a clean cloth.
 - b. Put the drive chain in kerosene and remove any remaining dirt.
 - c. Remove the drive chain from the kerosene and completely dry it.

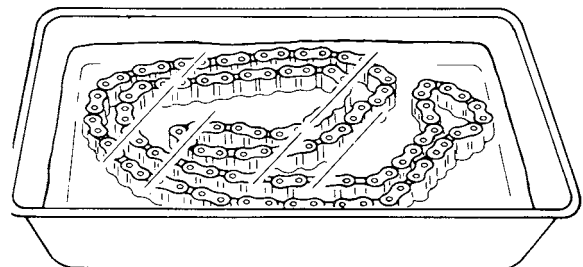

4. Check:

- Drive chain roller "1"
 - Drive chain side plate "2"
- Damage/wear → Replace the drive chain.

Damage/wear → Replace the drive chain.

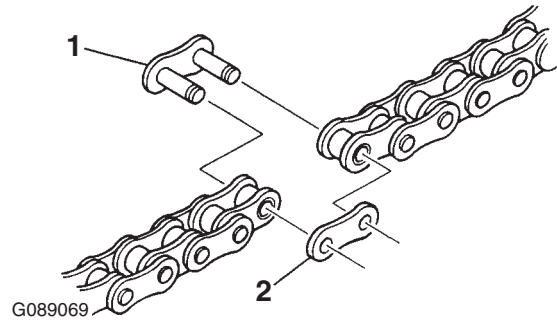
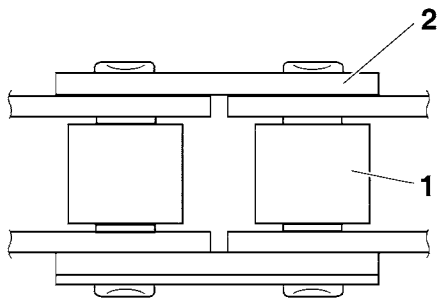

5. Lubricate:
- Drive chain

EAM30077

CHECKING THE DRIVE SPROCKET

1. Check:

- Drive sprocket
- More than 1/4 tooth wear “a” → Replace the drive sprocket and the rear wheel sprocket as a set.
- Bent tooth → Replace the drive sprocket and the rear wheel sprocket as a set.

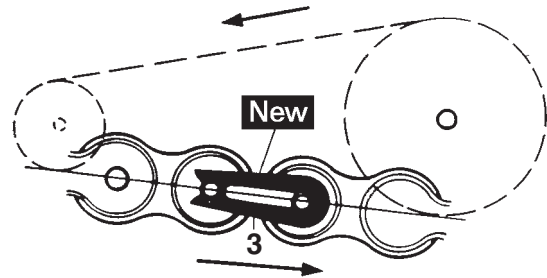

G089070

2. Lubricate:
- Drive chain
3. Install:
- Drive sprocket
 - Lock washer **New**
 - Drive sprocket nut

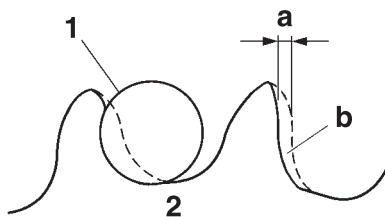

- b. Correct

1. Drive chain roller
2. Drive sprocket

EAM30078

CHECKING THE REAR WHEEL SPROCKET

Refer to “CHECKING AND REPLACING THE REAR WHEEL SPROCKET” on page 4-4.

EAM30079

INSTALLING THE DRIVE CHAIN

1. Install:

- Master link “1”
- Master link plate “2”
- Master link clip “3” **New**

EWA20250

WARNING

When installing the joint clip, always keep the direction as shown in the figure.

	Drive sprocket nut 75 N·m (7.5 kgf·m, 55 lb·ft)
---	--

ECA14300

NOTICE

Never install a new drive chain onto worn drive chain sprockets; this will dramatically shorten the drive chain’s life.

TIP

After the drive sprocket nut has been tightened to specification, firmly bend the lock washer tabs “a” along the flat of the drive sprocket nut.

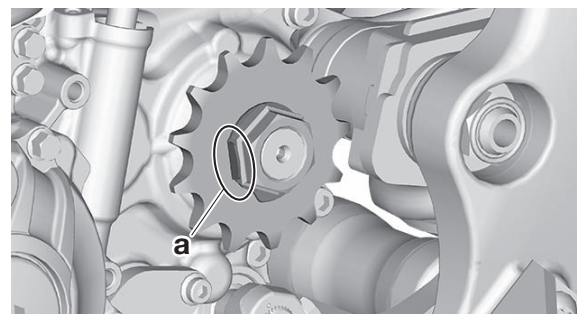

4. Adjust:

- Drive chain slack
- Refer to “DRIVE CHAIN SLACK” on page 3-23.



Drive chain slack (Maintenance Stand)
50.0–60.0 mm (1.97–2.36 in)

ECA24590

NOTICE

A drive chain that is too tight will overload the engine and other vital parts, and one that is too loose can skip and damage the swing-arm or cause an accident. Therefore, keep the drive chain slack within the specified limits.

ENGINE

EXHAUST SYSTEM	5-1
INSTALLING THE EXHAUST PIPE AND MUFFLER	5-1
CLUTCH	5-3
REMOVING THE CLUTCH	5-3
CHECKING THE FRICTION PLATES	5-3
CHECKING THE CLUTCH PLATES	5-3
CHECKING THE CLUTCH SPRINGS	5-3
CHECKING THE CLUTCH HOUSING	5-3
CHECKING THE CLUTCH BOSS	5-4
CHECKING THE PRESSURE PLATE	5-4
CHECKING THE PUSH LEVER SHAFT	5-4
CHECKING THE PUSH RODS	5-4
CHECKING THE PRIMARY DRIVE GEAR	5-4
CHECKING THE PRIMARY DRIVEN GEAR	5-4
INSTALLING THE CLUTCH	5-4

EAM20199

EXHAUST SYSTEM

EAM30167

INSTALLING THE EXHAUST PIPE AND MUFFLER

1. Install:

- Gasket **New**
- Exhaust pipe 1 "1"
- Nut (exhaust pipe 1) "2"

	Nut (exhaust pipe 1) 10 N·m (1.0 kgf·m, 7.4 lb·ft)
---	---

TIP

First temporarily tighten all nuts to 7 N·m (0.7 kgf·m, 5.2 lb·ft). Then retighten them to 10 N·m (1.0 kgf·m, 7.4 lb·ft).

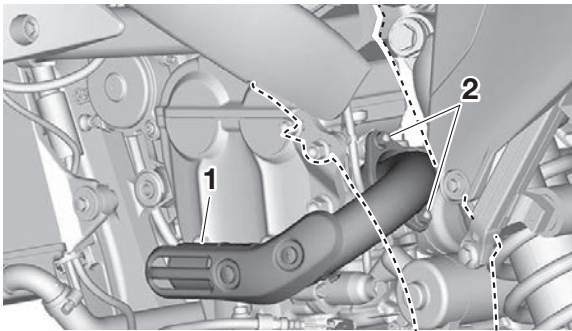

2. Install:

- Clamp
- Exhaust pipe 2 "1"
- Bolt (exhaust pipe 2) "2"

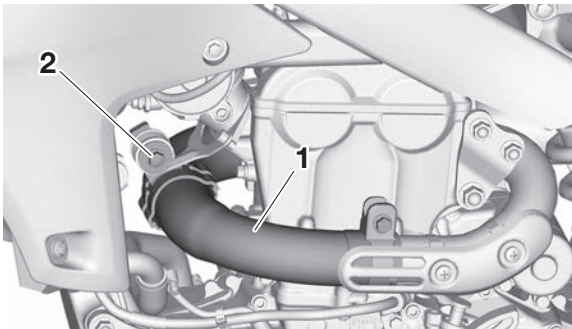

TIP

Install and temporarily tighten the exhaust pipe 2 and silencer with its end positioned as shown with respect to the exhaust pipe 1 and 2.

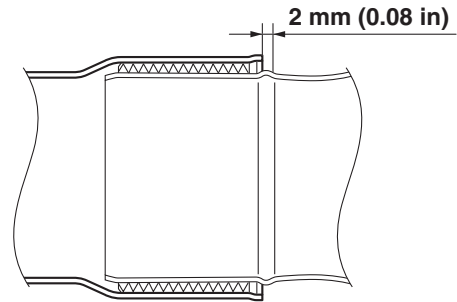

3. Install:

- Clamp
- Silencer "1"
- Bolt (silencer) "2"

	Bolt (silencer) 30 N·m (3.0 kgf·m, 22 lb·ft)
---	---

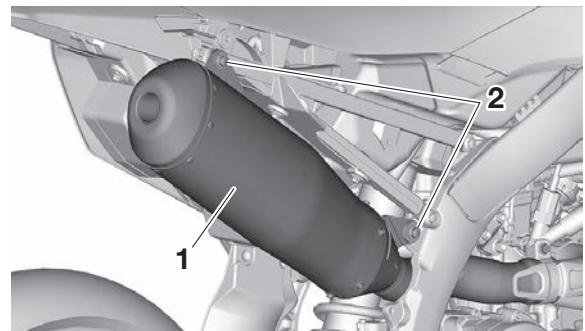

TIP

Install and temporarily tighten the silencer so that its joint is positioned as shown with respect to the exhaust pipe 2.

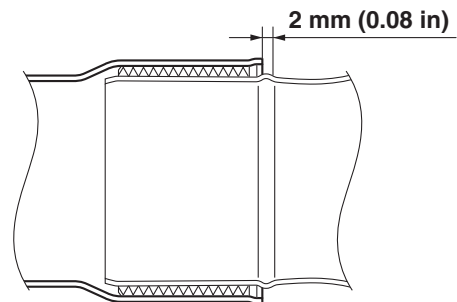

4. Tighten:

- Bolt (exhaust pipe 2)

	Bolt (exhaust pipe 2) 20 N·m (2.0 kgf·m, 15 lb·ft)
---	---

- Clamp "1"

	Clamp 12 N·m (1.2 kgf·m, 8.9 lb·ft)
---	--

TIP

- Tighten while checking that their front and rear

EXHAUST SYSTEM

joints are inserted in position.

- Make sure that the exhaust pipe clamp “1” does not ride on the projection “a” on the exhaust pipe “2” or silencer “3”. Be sure to insert the projection “b” into the slot in the exhaust pipe (or silencer).
-

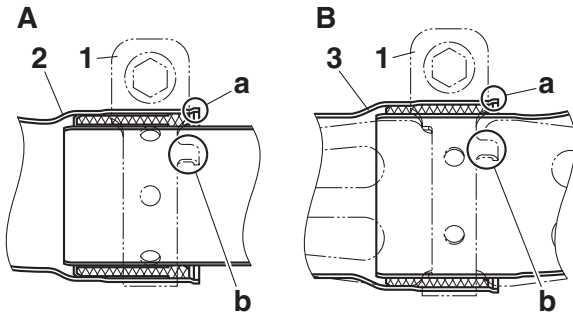

- A. Exhaust pipe 1 and exhaust pipe 2
- B. Exhaust pipe 2 and silencer

EAM20111

CLUTCH

EAM30108

REMOVING THE CLUTCH

1. Straighten the clutch boss nut rib "a".

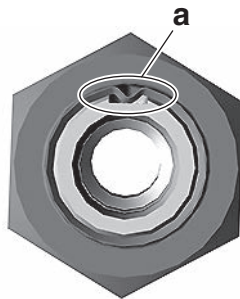

2. Remove:

- Clutch boss nut "1"
- Conical washer "2"
- Clutch boss "3"

TIP

- While holding the clutch boss with the clutch holder "4", loosen the clutch boss nut.
- Do not use an impact wrench for removing the clutch boss nut.



Clutch holder
90890-04199
Universal clutch holder
YM-91042

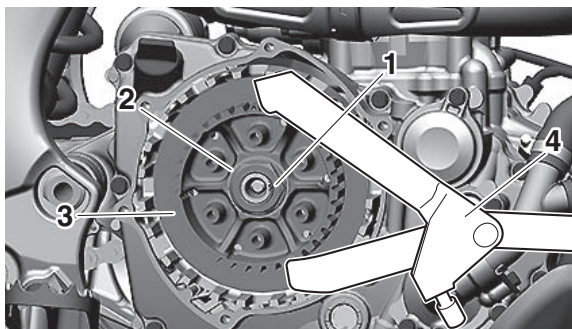

EAM30109

CHECKING THE FRICTION PLATES

1. Check:
 - Friction plate
 Damage/wear → Replace the friction plates as a set.
2. Measure:
 - Friction plate thickness
 Out of specification → Replace the friction plates as a set.

TIP

Measure it at four points on the friction plate.



Friction plate thickness
2.70–2.90 mm (0.106–0.114 in)
Wear limit
2.60 mm (0.102 in)

EAM30110

CHECKING THE CLUTCH PLATES

1. Check:
 - Clutch plate
 Damage → Replace the clutch plates as a set.
2. Measure:
 - Clutch plate warpage
 (with a surface plate and thickness gauge)
 Out of specification → Replace the clutch plates as a set.



Thickness gauge
90890-03268
Feeler gauge set
YU-26900-9



Clutch plate thickness
1.50–1.70 mm (0.059–0.067 in)
Warpage limit
0.10 mm (0.004 in)

EAM30111

CHECKING THE CLUTCH SPRINGS

1. Check:
 - Clutch spring
 Damage → Replace the clutch springs as a set.
2. Measure:
 - Clutch spring free length
 Out of specification → Replace the clutch springs as a set.



Clutch spring free length
46.20 mm (1.82 in)
Clutch spring free length limit
43.89 mm (1.73 in)

EAM30112

CHECKING THE CLUTCH HOUSING

1. Check:
 - Clutch housing dogs "1"
 Damage/pitting/wear → Deburr the clutch housing dogs or replace the clutch housing.

TIP

Pitting on the clutch housing dogs will cause erratic clutch operation.

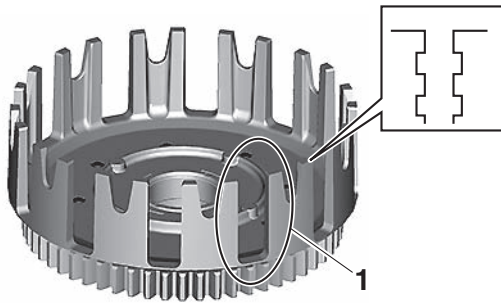

EAM30113

CHECKING THE CLUTCH BOSS

1. Check:
 - Clutch boss splines
Damage/pitting/wear → Replace the clutch boss.

TIP

Pitting on the clutch boss splines will cause erratic clutch operation.

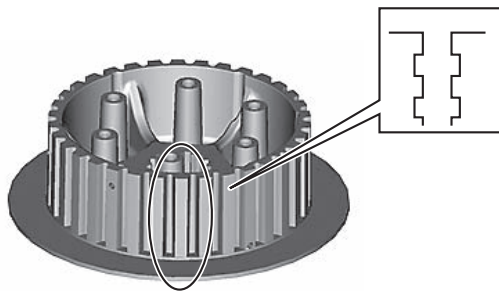

EAM30114

CHECKING THE PRESSURE PLATE

1. Check:
 - Pressure plate
Crack/damage → Replace.

EAM30115

CHECKING THE PUSH LEVER SHAFT

1. Check:
 - Push lever shaft
Wear/damage → Replace.

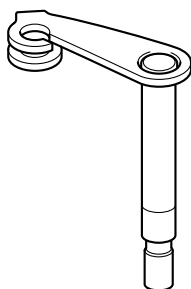

EAM30484

CHECKING THE PUSH RODS

1. Check:
 - Push rod 1 "1"
 - Bearing/Washer "2"
 - Push rod 2 "3"
 - Ball "4"
 Cracks/damage/wear → Replace.

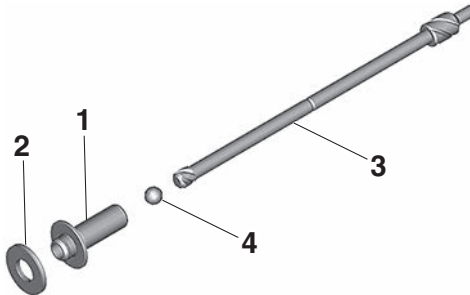

2. Measure:
 - Push rod 2 bending limit
Out of specification → Replace.



**Push rod bending limit
0.30 mm (0.012 in)**

EAM30117

CHECKING THE PRIMARY DRIVE GEAR

1. Check:
 - Primary drive gear
Damage/wear → Replace the primary drive and primary driven gears as a set.
Excessive noise during operation → Replace the primary drive and primary driven gears as a set.
2. Check:
 - Primary-drive-gear-to-primary-driven-gear free play
Free play exists → Replace the primary drive and primary driven gears as a set.

EAM30118

CHECKING THE PRIMARY DRIVEN GEAR

1. Check:
 - Primary driven gear
Damage/wear → Replace the primary drive and primary driven gears as a set.
Excessive noise during operation → Replace the primary drive and primary driven gears as a set.

EAM30121

INSTALLING THE CLUTCH

1. Install:
 - Dowel pin "1"
 - Gasket "2" **New**

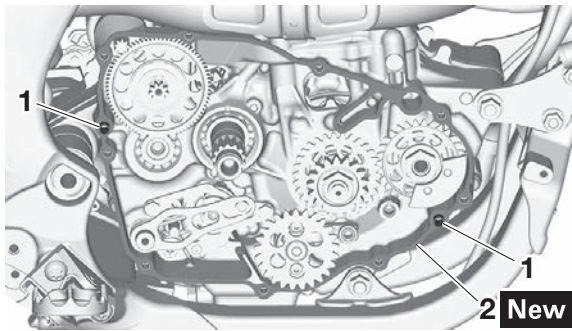

2. Install:

- Right crankcase cover “1”
- Right crankcase cover bolt “2”



Right crankcase cover bolt
10 N·m (1.0 kgf·m, 7.4 lb·ft)

TIP

Tighten the right crankcase cover bolts in stages and in a crisscross pattern.

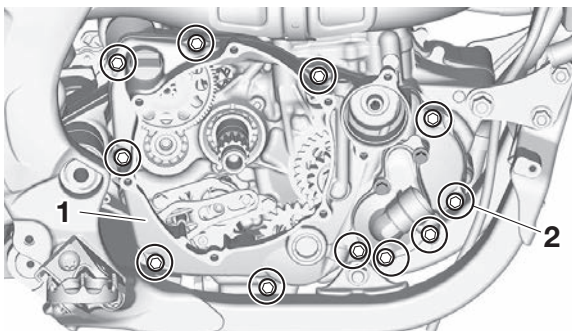

3. Install:

- Push lever shaft “1”

TIP

- Apply the lithium-soap-based grease on the oil seal lip.
- Before installation, apply the engine oil to the bearings (upper side and lower side).

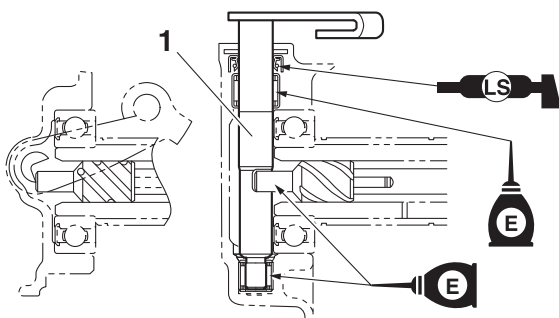

4. Install:

- Primary driven gear “1”
- Thrust washer “2”
- Clutch boss “3”

- Washer “4”

TIP

Apply the engine oil on the primary driven gear inner circumference.

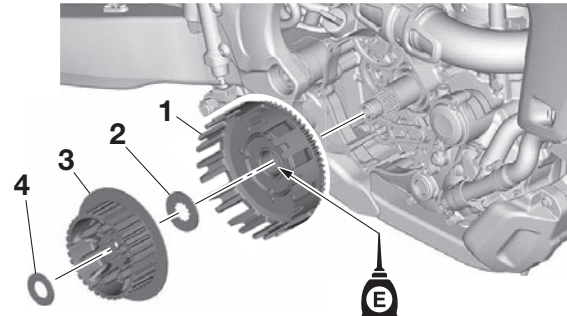

5. Install:

- Conical washer “1” **New**
- Clutch boss nut “2” **New**



Clutch boss nut
95 N·m (9.5 kgf·m, 70 lb·ft)

ECA24660

NOTICE

Make sure to tighten to specification; otherwise, it may damage the other part that is fastened together.

TIP

- Install the conical washer on the main axle with the “OUT” mark “a” facing away from the vehicle.
- Apply engine oil to the threads and contact surface of the clutch boss nut.
- Apply engine oil to the contact surfaces of the conical washer.
- Use the clutch holder “3” to hold the clutch boss.
- Do not use an impact wrench for installing the clutch boss nut.
- Stake the clutch boss nut at cutouts “b” in the main axle.



Clutch holder
90890-04199
Universal clutch holder
YM-91042

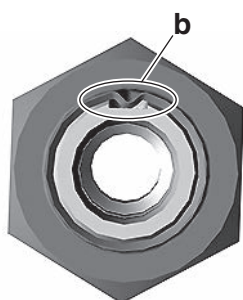
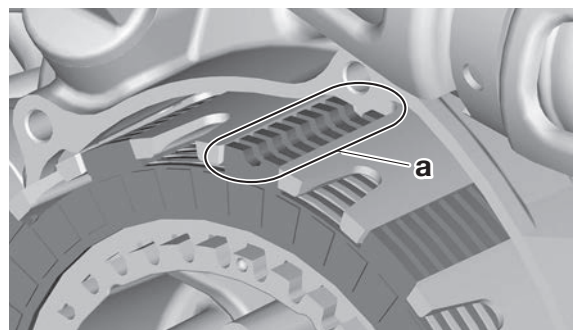
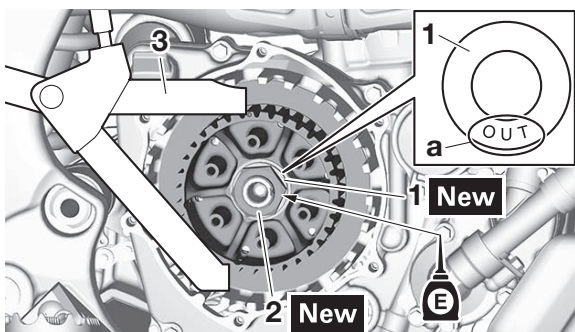

6. Install:

- Friction plate "1"
- Clutch plate "2"

TIP

- Install the clutch plates and friction plates alternately on the clutch boss, starting with a friction plate and ending with a friction plate.
- Align the friction plate with the groove "a" in the friction plate and install it to the primary driven gear.
- Apply the engine oil on the friction plates and clutch plates.

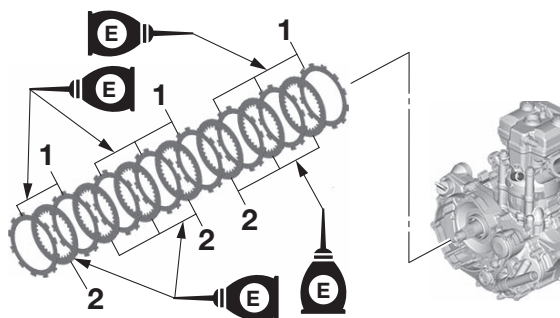

7. Install:

- Bearing "1"
- Washer "2"
- Circlip "3" **New**
(to the push rod 1 "4")

TIP

Apply the engine oil on the bearing, washer and push rod 1.

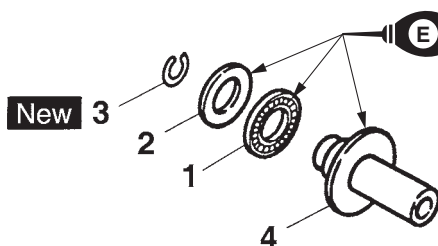

8. Install:

- Push rod 2 "1"
- Ball "2"
- Push rod 1 "3"

TIP

Apply the engine oil on the push rod 1, 2 and ball.

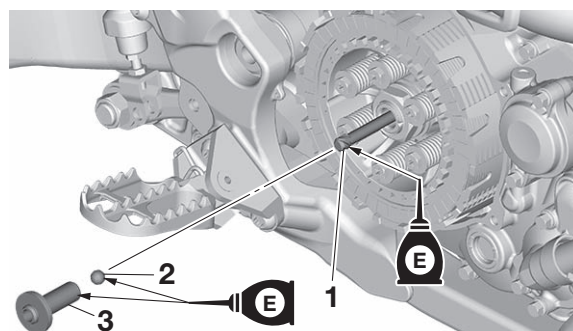

9. Install:

- Pressure plate "1"

TIP

Making sure to align a "a" on the pressure plate with the punch mark "b" on the clutch housing.

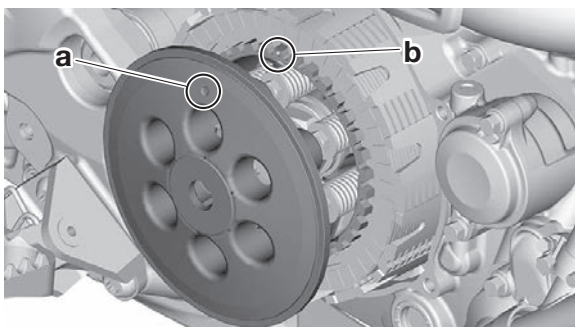
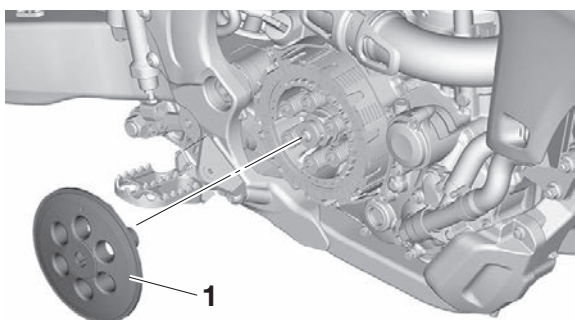

10.Install:

- Clutch spring
- Clutch spring bolt

	Clutch spring bolt 10 N·m (1.0 kgf·m, 7.4 lb·ft)
---	---

TIP

Tighten the bolts in stages and in a crisscross pattern.

11.Install:

- Gasket "1" **New**

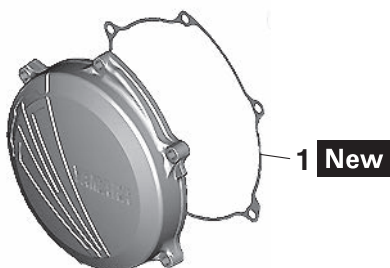

12.Install:

- Clutch cover
- Clutch cover bolt

	Clutch cover bolt 10 N·m (1.0 kgf·m, 7.4 lb·ft)
---	--

TIP

Tighten the bolts in stages and in a crisscross pattern.

FUEL SYSTEM

FUEL TANK	6-1
REMOVING THE FUEL TANK	6-1
INSTALLING THE FUEL TANK	6-1

EAM20140

FUEL TANK

EAM30263

REMOVING THE FUEL TANK

1. Extract the fuel in the fuel tank through the fuel tank cap with a pump.
2. Remove:
 - Seat
 - Side cover (left/right)
 - Shroud (left/right)
 Refer to "GENERAL CHASSIS" on page 4-1.
3. Disconnect:
 - Fuel pump coupler
 - Fuel hose

EWA19370

WARNING

Cover the fuel hose connection with a cloth when disconnecting it. This is because residual pressure in the fuel hose could cause fuel to spurt out when the hose is removed.

ECA24710

NOTICE

Make sure that the fuel hose is disconnected by hand. Do not forcefully disconnect the hose with tools.

TIP

- To disconnect the fuel hose from the fuel tank, remove the fuel hose connector holder "a", and then slide the fuel hose connector cover.
- To remove the fuel hose from the fuel rail, slide the fuel hose connector cover "1" on the end of the hose in the direction of the arrow shown, press the two buttons "2" on the sides of the connector, and then remove the hose.
- Before removing the hose, place a few cloths in the area under where it will be removed.
- To prevent sand, dust, and other foreign materials from entering the fuel pump, install the included fuel hose joint cover 1 "3" and the fuel hose joint cover 2 "4" onto the disconnected fuel hose and the fuel pump.

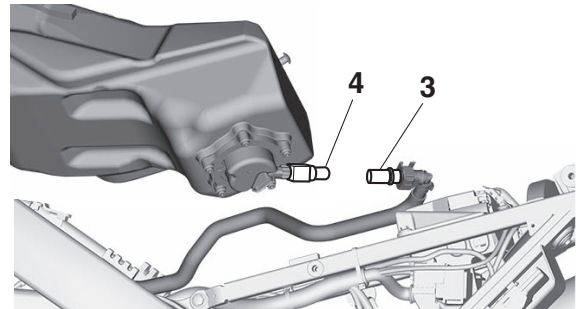
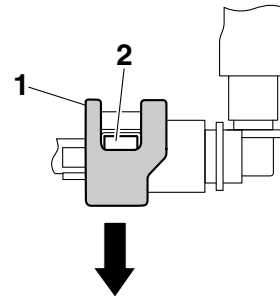
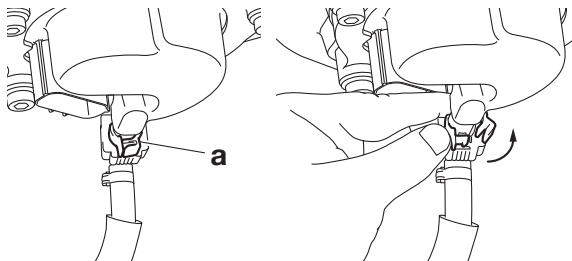

4. Remove:
 - Fuel tank

TIP

Do not set the fuel tank down on the installation surface of the fuel pump. Be sure to lean the fuel tank against a wall or the like.

EAM30267

INSTALLING THE FUEL TANK

1. Install:
 - Fuel tank
2. Connect:
 - Fuel hose

ECA24740

NOTICE

- Connect the fuel hose securely, and check that the orientation of the installed fuel hose holder is correct.
- Take care not to kink or pinch the fuel hose.

TIP

- Insert the fuel hose into the fuel pipe securely until you hear a "click".
- Slide the fuel hose connector cover "1" at the hose end in the direction of the arrow.
- Install the fuel hose connector holder "a".

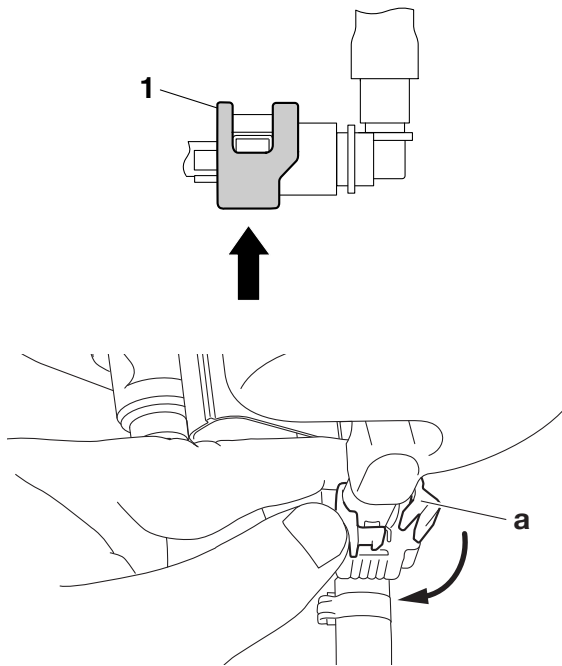

3. Connect:

- Fuel pump coupler

4. Install:

- Shroud (left/right)
- Side cover (left/right)
- Seat

Refer to "GENERAL CHASSIS" on page 4-1.

ELECTRICAL SYSTEM

ELECTRICAL COMPONENTS	7-1
CHECKING THE FUSES.....	7-1
CHECKING AND CHARGING THE BATTERY	7-1

EAM20147

ELECTRICAL COMPONENTS

EAM30290

CHECKING THE FUSES

The following procedure applies to all of the fuses.

1. Remove:
 - Seat
 - Side cover (left)
 Refer to "GENERAL CHASSIS" on page 4-1.
2. Check:
 - Fuse "1"

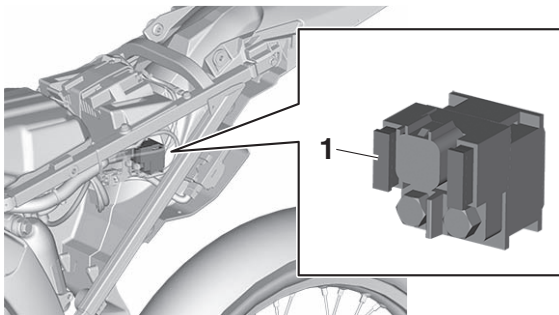

- a. Connect the digital circuit tester to the fuse and check the continuity.

TIP

Set the digital circuit tester selector to "Ω".



Digital circuit tester (CD732)
90890-03243
Model 88 Multimeter with tachometer
YU-A1927

- b. If the digital circuit tester indicates "O.L.", replace the fuse.

3. Replace:
 - Fuse
 - a. Install a new fuse of the correct amperage rating.
 - b. Push the start switch to verify if the electrical circuit is operational.
 - c. If the fuse immediately blows again, have a Yamaha dealer check the electrical system.

Fuses	Amperage rating	Q'ty
Main	15 A	1
Spare	15 A	1

EWA13310



Never use a fuse with an amperage rating

other than that specified. Improvising or using a fuse with the wrong amperage rating may cause extensive damage to the electrical system, cause the lighting and ignition systems to malfunction and could possibly cause a fire.

4. Install:
 - Side cover (left)
 - Seat

EAM30291

CHECKING AND CHARGING THE BATTERY

EWA20430



To avoid sparking, burns, fire, and explosion:

- Charge battery only with specified charger.
- Use battery only for specified product – no other use.
- Do not place near fire or immerse in water.
- Do not use battery if it has been dropped, subject to impact, or visibly damaged.
- Do not disassemble or modify the battery, or short across its terminals.

ECA28440



To prevent damage to the battery and battery malfunction:

- Be sure to charge the battery using only the specified battery charger. Do not use a charger designed for lead-acid batteries. Otherwise, the battery could be damaged, such as from a long period of excessive current or voltage exceeding 16 V.
- Avoid excessive current discharge, such as pressing the start switch for a long time. Wait for more than 10 seconds before attempting to start again. Charge the battery again as soon as possible. A long state of discharge below 10 V will damage the battery.
- Do not use the specified battery charger to charge a battery other than the lithium-ion battery. Otherwise, the battery or charger could be damaged.
- Be careful not to drop the battery or subject it to strong impacts.
- Avoid charging the battery at high temperatures of 65 °C (149 °F) or more or low temperatures under 0 °C (32 °F). A control feature preventing battery charging and discharging will temporarily intervene. The battery will discharge at 65 °C (149 °F) or more or low temperatures under -10 °C (14

°F).

- If the battery is charged between 0 °C (32 °F) and 10 °C (50 °F), battery charging may stop halfway without the battery becoming fully charged even when the specified battery charger is used. If this occurs, disconnect the battery charger, and then resume charging again.

TIP

This model uses a lithium-ion battery. When new, the battery is supplied in sleep mode to minimize current discharging until first-time use. In the sleep mode, a voltage as low as approximately 0.1 V can be measured if voltage measurement is performed. As such the battery cannot be used, but this is not a malfunction. By activating the battery as follows, the sleep mode will be canceled and the battery can be used normally.

Charging (activation) steps

1. Remove:
 - Seat
Refer to “GENERAL CHASSIS” on page 4-1.
2. Disconnect:
 - Battery lead
(from the battery terminals)

ECA13700

NOTICE

First, disconnect the negative battery lead, and then the positive battery lead.

3. Remove:
 - Battery
4. Connect the battery charger (special tool) to the battery.



**Lithium battery charger
90890-05376
Lithium battery charger
DBY-ACC51-70-02**

TIP

- For instructions on charging and handling the battery charger, refer to the battery charger’s instruction manual.
 - Once battery charging starts, the sleep mode is canceled.
5. Charge the battery until it is fully charged.
 6. Install:
 - Battery
 7. Connect:
 - Battery lead
(to the battery terminals)

ECA26980

NOTICE

First, connect the positive battery lead, and then the negative battery lead.

8. Check:
 - Battery terminal
Dirt → Clean with a wire brush.
Loose connection → Connect properly.
9. Lubricate:
 - Battery terminal



**Recommended lubricant
Dielectric grease**

10. Install:
 - Seat

Checking the battery

ECA26080

NOTICE

The battery has a limited service life. If the battery cannot be charged or it is determined that the battery cannot be used after checking the battery, it should be replaced. When replacing the battery, be sure to use a Yamaha genuine lithium-ion battery.

TIP

Do not check the battery at high temperature of 65 °C (149 °F) or more or low temperatures below 10 °C (50 °F). Otherwise, the control feature preventing battery charging and discharging will temporarily intervene.

1. Check:
 - Battery
 - a. If the battery is hot, wait until the battery has cooled down to the ambient temperature.
 - b. Measure the voltage between the battery terminals.
13.25 V or more → The battery is normal. Checking is finished.
Less than 13.25 V → Go to step (c).
 - c. Connect the battery charger (special tool) to the battery and charge it.



**Lithium battery charger
90890-05376
Lithium battery charger
DBY-ACC51-70-02**

TIP

For instructions on charging and handling the battery charger, refer to the battery charger’s instruction manual.

- d. If the battery is hot, wait until the battery has cooled down to the ambient temperature.
- e. Measure the voltage between the battery terminals.
 - 13.25 V or more → The battery is normal. Checking is finished.
 - 10 V or more and less than 13.25 V → Perform from step (c) again.
 - Less than 10 V → Replace the battery.

TIP

Before replacing the battery, make sure that the battery temperature is proper (temperature not more than 65 °C (149 °F) or less than 0 °C (32 °F)). Otherwise, wait until the battery temperature is proper and perform the procedure from step (c) again.

TROUBLESHOOTING

TROUBLESHOOTING	8-1
GENERAL INFORMATION	8-1
TROUBLESHOOTING OF ENGINE (fault code not detected)	8-1
TROUBLESHOOTING OF CLUTCH	8-4
TROUBLESHOOTING OF TRANSMISSION.....	8-6
TROUBLESHOOTING OF COOLING SYSTEM.....	8-7
TROUBLESHOOTING OF BRAKE.....	8-8
TROUBLESHOOTING OF SUSPENSION.....	8-8
TROUBLESHOOTING OF STEERING/HANDLING.....	8-10
TROUBLESHOOTING OF CHARGING SYSTEM	8-11

EAM20148

TROUBLESHOOTING

EAM30309

GENERAL INFORMATION

TIP

- Troubleshooting information provided here does not cover all the trouble symptoms, possible causes, and remedial actions. Some items may not apply depending on the model. Use this information as a guide and quick reference matrix when performing basic troubleshooting. Refer to the each chapter for detailed information on checking, adjustment, and replacement.
- The following guide for troubleshooting represent quick and easy procedures for checking these vital systems yourself. However, should your motorcycle require any repair, take it to a Yamaha dealer, whose skilled technicians have the necessary tools, experience, and know-how to service the motorcycle properly.

EAM30509

TROUBLESHOOTING OF ENGINE (fault code not detected)

TIP

If a fault code is detected, have a Yamaha dealer check the electrical system.

Engine does not crank.

Symptom	Possible cause	Actions
Starter motor does not operate	Have a Yamaha dealer check the electrical system.	
Starter motor operates, but the engine does not crank.	Starter clutch malfunction	Replace the starter clutch.
	Improper oil grade (starter clutch slipping)	Change to recommended engine oil.
	Stuck piston or seized crankshaft	Disassemble and check the engine. Replace defective parts.

Engine will not start or is difficult to start, but it cranks.

Symptom	Possible cause	Actions
Spark plug does not produce a spark	Have a Yamaha dealer check the electrical system.	
Fuel not supplied	—	Measure the fuel pressure.
	Empty fuel tank	Fill the fuel tank with fuel.
	Clogged fuel tank cap breather hole	Clean the fuel tank cap.
	Clogged or damaged fuel hose	Clean, repair, or replace the fuel hose.
	Fuel leakage	Check the fuel passage. Repair or replace as necessary.
	Clogged fuel pump	Clean or replace the fuel pump.
	Cracks or damage in fuel pump	Replace the fuel pump.
	Fuel pump malfunction	Have a Yamaha dealer check the electrical system.
	Failed or clogged fuel injector	Replace the fuel injector.
	ECU failure	Replace the ECU.

TROUBLESHOOTING

Symptom	Possible cause	Actions
—	Water or foreign material in fuel, degraded fuel	Change fuel.
	Loose spark plug	Tighten the spark plug to the specified torque.
	Loose cylinder head or cylinder	Tighten bolts or nuts on cylinder head and cylinder to the specified torque.
	Damaged cylinder head gasket	Replace the cylinder head gasket.
	Incorrect valve timing	Adjust the valve timing.
	Incorrect valve clearance	Adjust the valve clearance.
	Worn valve guide	Replace the valve guide.
	Bent, damaged, or stuck valve	Replace the valve.
	Poor contact between valve and valve seat	Reface the valve-to-valve-seat contact.
	Fatigued or broken valve spring	Replace the valve spring.
	Worn, damaged, or stuck piston ring	Replace the piston and piston rings as a set.
	Seized or damaged piston	Replace the piston and piston rings as a set.
	Worn or damaged cylinder bore	Replace the cylinder, piston, and piston rings as a set.

Incorrect idling speed or mid-to-high speed

Symptom	Possible cause	Actions
Spark plug does not produce a spark	Incorrect spark plug gap	Adjust the spark plug gap.
	Worn or damaged spark plug	Replace the spark plug.
	Defective spark plug cap	Replace the spark plug cap.
	Defective ignition coil	Replace the ignition coil.
	ECU failure	Replace the ECU.
Low fuel pressure	—	Measure the fuel pressure.
	Fuel leakage	Check the fuel passage. Repair or replace as necessary.
	Clogged fuel pump	Clean or replace the fuel pump.
	Cracks or damage in fuel pump	Replace the fuel pump.
	Fuel pump malfunction	Have a Yamaha dealer check the electrical system.
Fuel not supplied	Failed or clogged fuel injector	Replace the fuel injector.
	ECU failure	Replace the ECU.

TROUBLESHOOTING

Symptom	Possible cause	Actions
—	Worn camshaft lobe	Replace the camshaft.
	Water or foreign material in fuel, degraded fuel	Change fuel.
	Contaminated throttle body or clogged internal passage	Clean the throttle body.
	Incorrectly adjusted throttle cable	Adjust the throttle grip free play.
	Incorrectly adjusted idling speed (idle screw)	Adjust the idle screw.
	Incorrect throttle position sensor angle	Adjust the throttle position sensor angle.
	Incorrect acceleration position sensor angle	Adjust the acceleration position sensor angle.
	Faulty ECU	Replace the ECU.
	Clogged vacuum hose	Clean the vacuum hose.
	Cracks and damage in vacuum hose	Replace the vacuum hose.
	Damaged throttle body joint	Replace the throttle body joint.
	Loose throttle body joint	Tighten the throttle body joint bolts to the specified torque.
	Clogged air filter element	Clean or replace the air filter element.
	Incorrect oil level (high)	Adjust the oil level to the specified level.

Excessive noise from engine

Symptom	Possible cause	Actions
Noise heard from around cylinder head	Incorrect valve clearance (too wide)	Adjust the valve clearance.
	Fatigued or broken valve spring	Replace the valve spring.
	Worn or damaged camshaft lobe	Replace the camshaft.
	Worn or damaged valve lifter	Replace the valve lifter and cylinder head as a set.
	Worn or damaged camshaft journal	Replace the camshaft.
	Worn or damaged cylinder head (camshaft journal)	Replace the cylinder head.
Noise heard from around timing chain	Worn or damaged timing chain	Replace the timing chain and camshaft sprocket as a set.
	Worn or damaged camshaft sprocket	Replace the timing chain and camshaft sprocket as a set.
	Worn or damaged timing chain guide	Replace the timing chain guide.
	Cracked, damaged, or faulty timing chain tensioner	Replace the timing chain tensioner.

TROUBLESHOOTING

Symptom	Possible cause	Actions
Noise heard from around piston	Worn or damaged piston ring	Replace the piston and piston rings as a set.
	Worn or damaged piston	Replace the piston and piston rings as a set.
	Worn piston (piston pin hole)	Replace the piston and piston pin as a set.
	Worn or damaged piston pin	Replace the piston pin.
	Worn or damaged cylinder bore	Replace the cylinder, piston, and piston rings as a set.
	Carbon buildup in piston head and combustion chamber	Clean the piston head and combustion chamber.
Noise heard from around crankshaft	Worn or damaged crankshaft journal or crank pin	Replace the crankshaft.
	Cracked, worn, or damaged balancer shaft	Replace the balancer drive gear and balancer shaft as a set.
	Worn or damaged balancer drive gear	Replace the balancer drive gear and balancer shaft as a set.
	Worn or damaged big end bearing	Replace the big end bearing.
	Worn or damaged crankshaft journal bearing	Replace the crankshaft journal bearing.
	Worn or damaged balancer shaft journal bearing	Replace the balancer shaft journal bearing.

EAM30510

TROUBLESHOOTING OF CLUTCH

Manual clutch

Symptom	Possible cause	Actions
Clutch slippage	Improperly assembled clutch	Reassemble the clutch.
	Improperly adjusted clutch cable	Adjust the clutch lever free play.
	Loose clutch spring	Tighten the clutch spring bolts to the specified torque.
	Fatigued clutch spring	Replace the clutch springs as a set.
	Warped pressure plate	Replace the pressure plate.
	Worn friction plate	Replace the friction plates as a set.
	Warped or worn clutch plate	Replace the clutch plates as a set.
	Incorrect oil level	Adjust the engine oil level to the specified level.
	Incorrect oil viscosity (low)	Change to recommended engine oil.
	Deteriorated oil	Change to recommended engine oil.

TROUBLESHOOTING

Symptom	Possible cause	Actions
Clutch drags	Faulty clutch spring	Replace the clutch springs as a set.
	Warped pressure plate	Replace the pressure plate.
	Swollen friction plate	Replace the friction plates as a set.
	Warped clutch plate	Replace the clutch plates as a set.
	Bent pull rod (outer pull type)	Replace the pull rod.
	Worn pull rod tooth (outer pull type)	Replace the pull rod and pull lever shaft as a set.
	Bent push rod (inner push type)	Replace the push rod.
	Damaged or worn clutch boss	Replace the clutch boss.
	Seized clutch housing bushing	Replace the clutch housing.
	Improperly installed pull lever	Align the match mark on the pull lever before installation.
	Incorrect oil level	Adjust the engine oil level to the specified level.
	Incorrect oil viscosity (high)	Change to recommended engine oil.
	Deteriorated oil	Change to recommended engine oil.
Clutch noise	Damaged or worn primary driven gear	Replace the primary drive gear or crankshaft, and the clutch housing as a set.
	Loose clutch boss nut	Tighten the clutch boss nut to the specified torque.
	Fatigued clutch damper	Replace the clutch housing.
	Worn clutch housing bearing	Replace the clutch housing bearing.
	Worn pressure plate bearing	Replace the pressure plate bearing.

TROUBLESHOOTING

EAM30511

TROUBLESHOOTING OF TRANSMISSION

Symptom	Possible cause	Actions
Difficult or impossible to shift transmission gear	Clutch drags	Refer to "Clutch drags".
	Improperly adjusted shift rod	Adjust the shift rod installation length.
	Bent shift shaft	Replace the shift shaft.
	Foreign object in a shift drum groove	Remove foreign object from shift drum groove.
	Damaged shift drum	Replace the shift drum.
	Seized shift fork	Replace the shift fork and shift fork guide bar as a set.
	Bent shift fork guide bar	Replace the shift fork guide bar.
	Foreign object between transmission gears	Remove foreign object from transmission gears.
	Seized transmission gear	Replace the seized gear and the axle as a set.
	Improperly assembled transmission	Reassemble the transmission axle assembly.
Jumps out of gear	Incorrect shift pedal position	Adjust the shift pedal position.
	Improperly returned stopper lever	Replace the stopper lever spring.
	Bent or worn shift fork	Replace the shift fork.
	Shift drum incorrect axial play	Replace the shift drum.
	Worn shift drum groove	Replace the shift drum.
	Worn transmission gear dog	Replace the transmission gear.
Transmission noise	Damaged or worn transmission gear	Replace the transmission gear.
	Worn main axle spline	Replace the main axle.
	Worn drive axle spline	Replace the drive axle.
	Worn bearing	Replace the bearing.

TROUBLESHOOTING

EAM30512

TROUBLESHOOTING OF COOLING SYSTEM

Symptom	Possible cause	Actions
Overheating	Carbon buildup in piston head and combustion chamber	Clean the piston head and combustion chamber.
	Clogged engine cooling water passages	Check and clean the engine cooling water passages.
	Incorrect oil level	Adjust the oil level to the specified level.
	Incorrect oil viscosity	Change to recommended engine oil.
	Inferior oil quality	Change to recommended engine oil.
	Low coolant level	Add recommended coolant to the specified level.
	Damaged or leaking radiator	Replace the radiator.
	Faulty radiator cap	Replace the radiator cap.
	Clogged radiator fin	Clean the radiator fin.
	Bent or damaged radiator fin	Repair the radiator fin or replace the radiator.
	Damaged or faulty water pump	Replace the water pump.
	Damaged hoses or pipes	Replace the hose or pipe.
	Improperly connected hoses or pipes	Connect the hoses and pipes properly.
	Damaged throttle body joint	Replace the throttle body joint.
	Loose throttle body joint	Tighten the throttle body joint bolts to the specified torque.
	Clogged air filter element	Clean or replace the air filter element.
	Brake drags	Check the brake system and repair or replace faulty parts as necessary.
Incorrect spark plug gap	Adjust to the specified spark plug gap.	
Incorrect spark plug heat range	Replace the spark plug with the one of the specified type.	
Faulty ECU	Replace the ECU.	
Noise from water pump	Contact between the water pump housing cover and impeller	Disassemble the water pump and replace faulty parts.
	Worn water pump housing bearing	Replace the water pump housing bearing.

TROUBLESHOOTING

EAM30513

TROUBLESHOOTING OF BRAKE

Symptom	Possible cause	Actions
Poor performance of disc brake	Worn brake pad	Replace the brake pads as a set.
	Worn or deflected brake disc	Replace the brake disc.
	Air in hydraulic brake system	Bleed the hydraulic brake system.
	Brake fluid leakage	Check the hydraulic brake system and repair or replace faulty parts as necessary.
	Incorrect brake fluid level (low)	Add brake fluid to the specified level.
	Stuck brake caliper piston	Replace the caliper piston seal.
	Stuck brake caliper and slide pin	Lubricate the caliper slide pin.
	Loose union bolt	Tighten the union bolt to the specified torque.
	Damaged brake hose and brake pipe	Replace the brake hose and brake pipe.
	Oil or grease on the brake disc or brake pad	Clean the brake disc or brake pad.
	Insufficient lubrication of brake lever or brake pedal pivot	Lubricate the brake lever or brake pedal pivot.

EAM30514

TROUBLESHOOTING OF SUSPENSION

Symptom	Possible cause	Actions
Front fork is hard	Bent or damaged inner tube	Replace the inner tube.
	Bent or damaged outer tube	Replace the outer tube.
	Damaged or worn slide metal	Replace the slide metal.
	Bent or damaged damper rod	Replace the damper rod.
	Bent wheel axle	Replace the wheel axle.
	Incorrect oil viscosity (high)	Change to recommended fork oil.
	Incorrect oil level (high)	Adjust to the specified oil level.
	Improperly adjusted spring preload (hard)	Adjust the spring preload.
	Improperly adjusted rebound damping (hard)	Adjust the rebound damping.
	Improperly adjusted compression damping (hard)	Adjust the compression damping.

TROUBLESHOOTING

Symptom	Possible cause	Actions
Front fork is soft	Fatigued or broken fork spring	Replace the fork spring.
	Incorrect oil viscosity (low)	Change to recommended fork oil.
	Incorrect oil level (low)	Adjust to the specified oil level.
	Improperly adjusted spring preload (soft)	Adjust the spring preload.
	Improperly adjusted rebound damping (soft)	Adjust the rebound damping.
	Improperly adjusted compression damping (soft)	Adjust the compression damping.
Leaking oil from front fork	Bent, damaged, or corroded inner tube	Replace the inner tube.
	Cracked or damaged outer tube	Replace the outer tube.
	Improperly installed oil seal	Replace the oil seal.
	Damaged oil seal lip	Replace the oil seal.
	Incorrect oil level (high)	Adjust to the specified oil level.
	Loose damper rod assembly bolt	Tighten the damper rod assembly bolt to the specified torque.
	Damaged damper rod assembly bolt copper washer	Replace the damper rod assembly bolt copper washer.
	Cracked or damaged cap bolt O-ring	Replace the cap bolt O-ring.
Rear suspension is hard	Bent or damaged rear shock absorber rod	Replace the rear shock absorber.
	Bent swingarm pivot shaft	Replace the swingarm pivot shaft.
	Damaged or worn swingarm bearing or bushing	Replace the swingarm bearing or bushing.
	Damaged or worn relay arm bearing	Replace the relay arm bearing.
	Damaged or worn connecting arm bearing	Replace the connecting arm bearing.
	Improperly adjusted rear shock absorber spring preload (hard)	Adjust the spring preload.
	Improperly adjusted rear shock absorber rebound damping (hard)	Adjust the rebound damping.
	Improperly adjusted rear shock absorber compression damping (hard)	Adjust the compression damping.

TROUBLESHOOTING

Symptom	Possible cause	Actions
Rear suspension is soft	Oil leaking from rear shock absorber	Replace the rear shock absorber.
	Gas leaking from rear shock absorber	Replace the rear shock absorber.
	Fatigued or damaged rear shock absorber spring	Replace the rear shock absorber.
	Improperly adjusted rear shock absorber spring preload (soft)	Adjust the spring preload.
	Improperly adjusted rear shock absorber rebound damping (soft)	Adjust the rebound damping.
	Improperly adjusted rear shock absorber compression damping (soft)	Adjust the compression damping.
Oil leaking from rear shock absorber	Bent, damaged, or corroded rear shock absorber rod	Replace the rear shock absorber.
	Damaged oil seal lip	Replace the rear shock absorber.

EAM30515

TROUBLESHOOTING OF STEERING/HANDLING

Symptom	Possible cause	Actions
Handlebar wobble	Loose lower ring nut	Tighten the lower ring nut to the specified torque.
	Worn bearing or bearing race	Replace the bearing and bearing race as a set.
	Warped front fork	Repair or replace the front fork.
	Bent front wheel axle	Replace the front wheel axle.
	Incorrect tire pressure	Adjust to the specified tire pressure.
	Worn, deformed, or incorrect tire	Replace the tire.
Heavy steering	Lower ring nut is tightened too tight.	Tighten the lower ring nut to the specified torque.
	Bent lower bracket	Replace the lower bracket.
	Broken bearing or bearing race	Replace the bearing and bearing race as a set.
	Incorrect tire pressure	Adjust to the specified tire pressure.
Front wheel vibration	Loose spoke	Tighten the spoke and adjust the runout.
	Damaged or worn wheel bearing	Replace the wheel bearing.
	Worn, deformed, or incorrect tire	Replace the tire.
	Loose wheel axle or wheel axle nut	Tighten the wheel axle or wheel axle nut to the specified torque.
	Loose wheel axle pinch bolt	Tighten the wheel axle pinch bolt to the specified torque.
	Incorrect front fork oil level	Adjust to the specified front fork oil level.

TROUBLESHOOTING

Symptom	Possible cause	Actions
Rear wheel vibration	Loose spoke	Tighten the spoke and adjust the runout.
	Damaged or worn wheel bearing	Replace the wheel bearing.
	Worn, deformed, or incorrect tire	Replace the tire.
	Loose wheel axle nut	Tighten the wheel axle nut to the specified torque.
	Loose swingarm pivot shaft	Tighten the swingarm pivot shaft to the specified torque.
	Bent or damaged swingarm	Replace the swingarm bearing.
	Damaged or worn swingarm bearing or bushing	Replace the swingarm bearing or bushing.

EAM30516

TROUBLESHOOTING OF CHARGING SYSTEM

Symptom	Possible cause	Actions
Battery is not charged	Have a Yamaha dealer check the electrical system.	

TUNING

CHASSIS	9-1
SELECTION OF THE SECONDARY REDUCTION RATIO (SPROCKET)....	9-1
DRIVE AND REAR WHEEL SPROCKETS SETTING PARTS	9-1
TIRE PRESSURE	9-1
FRONT FORK SETTING	9-2
CHANGE IN AMOUNT AND CHARACTERISTICS OF FORK OIL	9-2
SETTING OF SPRING AFTER REPLACEMENT	9-2
FRONT FORK SETTING PARTS.....	9-3
REAR SUSPENSION SETTING	9-3
CHOOSING SET LENGTH.....	9-3
SETTING OF SPRING AFTER REPLACEMENT	9-4
REAR SHOCK ABSORBER SETTING PARTS.....	9-4
SUSPENSION SETTING (FRONT FORK)	9-5
SUSPENSION SETTING (REAR SHOCK ABSORBER)	9-6

EAM20119

CHASSIS

EAM30168

SELECTION OF THE SECONDARY REDUCTION RATIO (SPROCKET)

Secondary reduction ratio = Number of rear wheel sprocket teeth/Number of drive sprocket teeth



**Secondary reduction ratio
3.846 (50/13)**

<Requirement for selection of secondary gear reduction ratio>

- It is generally said that the secondary gear ratio should be reduced for a longer straight portion of a speed course and should be increased for a course with many corners. Actually, however, as the speed depends on the ground condition of the day of the race, be sure to run through the circuit to set the machine suitable for the entire course.
- In actuality, it is very difficult to achieve settings suitable for the entire course and some settings may be sacrificed. Thus, the settings should be matched to the portion of the course that has the greatest effect on the race result. In such a case, run through the entire course while making notes of lap times to find the best balance; then, determine the secondary reduction ratio.
- If a course has a long straight portion where a machine can run at maximum speed, the machine is generally set such that it can develop its maximum revolutions toward the end of the straight line, with care taken to avoid the engine over-revving.

TIP

Riding technique varies from rider to rider and the performance of a machine also vary from machine to machine. Therefore, do not imitate other rider's settings from the beginning but choose your own setting according to the level of your riding technique.

EAM30169

DRIVE AND REAR WHEEL SPROCKETS SETTING PARTS

Part name	Type	Part number
Drive sprocket "1"	(STD)	13T 9383B-13218

Part name	Type	Part number
Rear wheel sprocket "2"	47T	17D-25447-50
	48T	17D-25448-50
	49T	B2W-25449-00
	(STD)	50T B2W-25450-00
	51T	B2W-25451-00
	52T	17D-25452-50

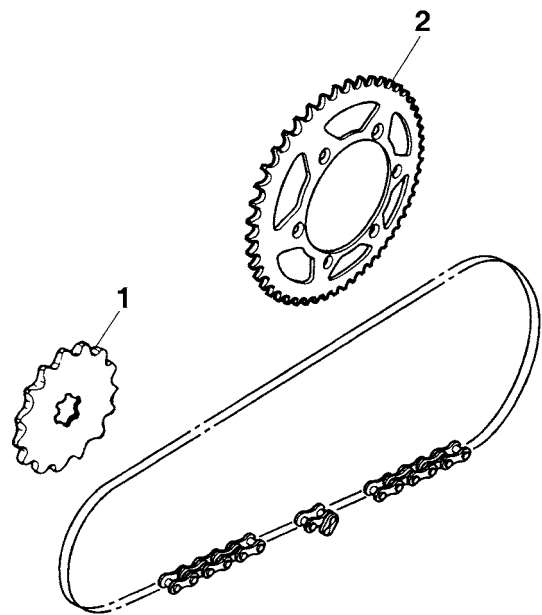

EAM30170

TIRE PRESSURE

Tire pressure should be adjusted to suit the road surface condition of the circuit.



**Standard tire pressure
100 kPa (1.00 kgf/cm², 15 psi)**

- Under a rainy, a muddy, a sandy, or a slippery condition, the tire pressure should be lower for a larger area of contact with the road surface.



**Extent of adjustment
60–80 kPa (0.60–0.80 kgf/cm², 9–12 psi)**

- Under a stony or a hard road condition, the tire pressure should be higher to prevent a flat tire.



**Extent of adjustment
100–120 kPa (1.00–1.20 kgf/cm², 15–18 psi)**

EAM30171

FRONT FORK SETTING

The front fork setting should be made depending on the rider's feeling of an actual run and the circuit conditions.

The front fork setting includes the following three factors:

1. Setting of air spring characteristics
 - Change the fork oil amount.
2. Setting of spring preload
 - Change the spring.
3. Setting of damping force
 - Change the compression damping force.
 - Change the rebound damping force.

The spring acts on the load and the damping force acts on the cushion travel speed.

EAM30172

CHANGE IN AMOUNT AND CHARACTERISTICS OF FORK OIL

Damping characteristic near the final stroke can be changed by changing the fork oil amount.

EWA19190

WARNING

Adjust the oil amount in 5 cm³ (0.2 US oz, 0.2 Imp.oz) increments or decrements. Too small oil amount causes the front fork to produce a noise at full rebound or the rider to feel some pressure on his hands or body. Alternatively, too large oil amount will cause the air spring characteristics to have a tendency to be stiffer with the consequent deteriorated performance and characteristics. Therefore, adjust the front fork within the specified range.



Recommended oil
Yamaha Suspension Oil S1
Standard oil amount
280 cm³ (9.47 US oz, 9.88 Imp.oz)
Extent of adjustment
260–365 cm³ (8.79–12.34 US oz, 9.17–12.87 Imp.oz)

A

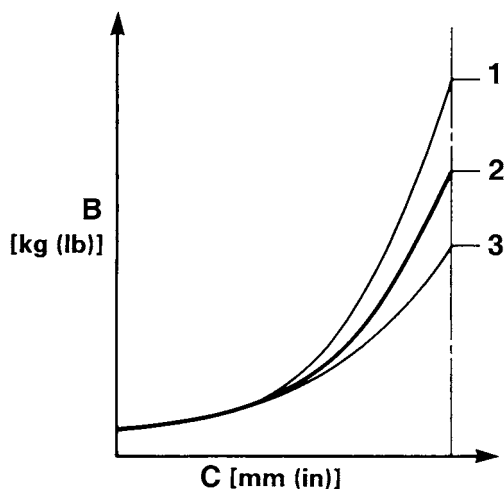

A. Air spring characteristics in relation to oil amount change

B. Load

C. Stroke

1. Max. oil amount
2. Standard oil amount
3. Min. oil amount

EAM30173

SETTING OF SPRING AFTER REPLACEMENT

As the front fork setting can be easily affected by the rear suspension, take care so that the front and the rear are balanced (in position etc.) when setting the front fork.

1. Use of soft spring
 - Change the rebound damping force.
Turn out one or two clicks.
 - Change the compression damping force.
Turn in one or two clicks.

TIP

Generally a soft spring gives a soft riding feeling. Rebound damping tends to become stronger and the front fork may sink deeply over a series of gaps.

2. Use of stiff spring
 - Change the rebound damping force.
Turn in one or two clicks.
 - Change the compression damping force.
Turn out one or two clicks.

TIP

Generally a stiff spring gives a stiff riding feeling. Rebound damping tends to become weaker, resulting in lack of a sense of contact with the road surface or in a vibrating handlebar.

EAM30174

FRONT FORK SETTING PARTS

- Front fork spring

STD Spring rate N/mm		4.7	
Type	Spring rate N/mm	Part number	I.D. mark (slits)
↑	4.5	BR9-23141-20	I-II
	4.6	BR9-23141-30	I-III
	4.7	BR9-23141-40	I-III
	4.8	BR9-23141-50	I-III
↓	4.9	BR9-23141-60	II-II
	5.0	BR9-23141-70	II-III
	5.1	BR9-23141-80	II-III
STIFF			

TIP

The I.D. mark (slits) is proved on the end of the spring.

EAM30175

REAR SUSPENSION SETTING

The rear shock absorber setting should be made depending on the rider's feeling of an actual run and the circuit conditions.

The rear suspension setting includes the following two factors:

1. Setting of spring preload
 - Change the set length of the spring.
 - Change the spring.
2. Setting of damping force
 - Change the rebound damping force.
 - Change the compression damping force.

EAM30176

CHOOSING SET LENGTH

1. Place a stand or a block under the engine to put the rear wheel above the floor, and measure the length "a" between the rear wheel axle center and "△" mark of rear fender.

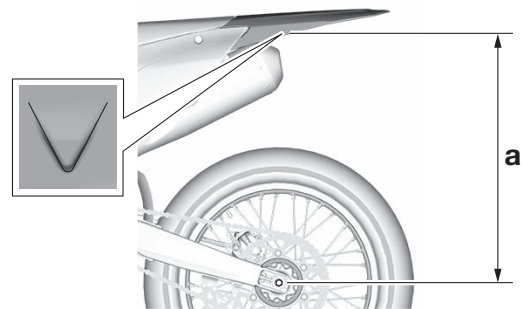

2. Remove the stand or block from the engine and, with a rider astride the seat, measure the sunken length "b" between the rear wheel axle center and "△" mark of rear fender.

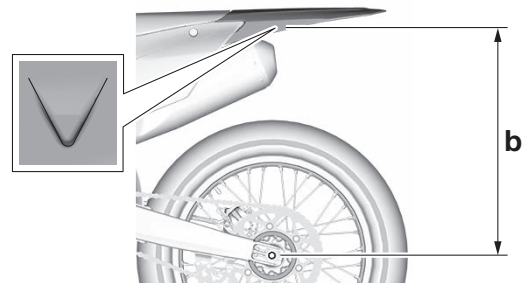

3. Loosen the locknut "1" and make adjustment by turning the adjuster "2" to achieve the standard figure from the subtraction of the length "b" from the length "a".



Standard figure
90–100 mm (3.5–3.9 in)

TIP

- If the machine is new and after it is broken in, the same set length of the spring may change because of the initial fatigue, etc. of the spring. Therefore, be sure to make reevaluation.
- If the standard figure cannot be achieved by adjusting the adjuster and changing the set length, replace the spring with an optional one and make readjustment.

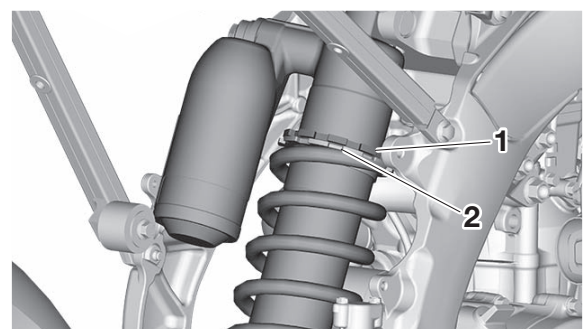

EAM30177

SETTING OF SPRING AFTER REPLACEMENT

After replacement, be sure to adjust the spring to the set length [sunken length 90–100 mm (3.5–3.9 in)] and set it.

1. Use of soft spring

- Adjust to decrease rebound damping force to compensate for less spring load. Run with the rebound damping force adjuster one or two clicks turned out, and readjust it to suit your preference.

2. Use of stiff spring

- Adjust to increase rebound damping force to compensate for greater spring load. Run with the rebound damping force adjuster one or two clicks turned in, and readjust it to suit your preference.

TIP

Adjusting the rebound damping force will be followed more or less by a change in the compression damping force. For correction, adjust to decrease compression damping force.

EWA19200

WARNING

When using a rear shock absorber other than currently installed, use the one whose overall length “a” does not exceed the standard as it may result in faulty performance. Never use one whose overall length is greater than standard.

 Length “a” of standard shock 460.5 mm (18.1 in)

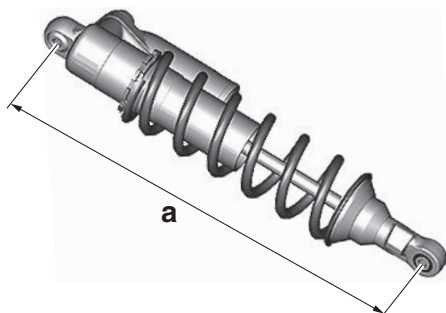

EAM30178

REAR SHOCK ABSORBER SETTING PARTS

- Rear shock spring “1”

STD Spring rate N/mm		56	
Type	Spring rate N/mm	Part number	I.D. mark
SOFT ↑	52	BR9-22212-00 (Blue)	Yellow
	54	BR9-22212-10 (Blue)	Pink
	56	BR9-22212-A0 (Silver)	White
↓ STIFF	58	BR9-22212-B0 (Silver)	Gold
	60	BR9-22212-40 (Blue)	Brown

TIP

- The I.D. mark “a” is marked at the end of the spring.
- Spring specification varies according to the color of I.D. marks.

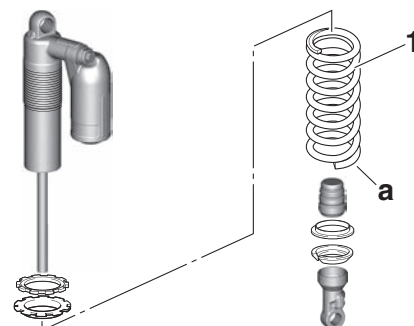

- Spring preload adjusting positions

 **Spring preload adjusting positions**

Minimum
Position in which the spring is turned in 1.5 mm (0.06 in) from its free length.

Standard
Position in which the spring is turned in 5.0 mm (0.20 in) from its free length.

Maximum
Position in which the spring is turned in 18.0 mm (0.71 in) from its free length.

TIP

For the spring preload adjustment, refer to “ADJUSTING THE REAR SHOCK ABSORBER ASSEMBLY” on page 3-27.

EAM30179

SUSPENSION SETTING (FRONT FORK)

TIP

- If any of the following symptoms is experienced with the standard position as the base, make resetting by reference to the adjustment procedure given in the same chart.
- Before any change, set the rear shock absorber sunken length to the standard figure 90–100 mm (3.5–3.9 in).

Symptom	Section				Check	Adjust
	Jump	Large gap	Medium gap	Small gap		
Stiff over entire range	√	√	√		Compression damping force	Turn adjuster counterclockwise (about 2 clicks) to decrease damping.
					Oil amount	Decrease oil amount by about 5–10 cm ³ (0.2–0.3 US oz, 0.2–0.4 Imp.oz).
					Spring	Replace with soft spring.
Unsmooth movement over entire range	√	√	√	√	Outer tube Inner tube	Check for any bends, dents, other noticeable scars, etc. If any, replace affected parts.
					Slide metal	Replace with a new one for extended use.
					Piston metal	Replace with a new one for extended use.
					Lower bracket tightening torque	Retighten to specified torque.
Poor initial movement				√	Rebound damping force	Turn adjuster counterclockwise (about 2 clicks) to decrease damping.
					Oil seals	Apply grease in oil seal wall.
Soft over entire range, bottoming out	√	√			Compression damping force	Turn adjuster clockwise (about 2 clicks) to increase damping.
					Oil amount	Increase oil amount by about 5–10 cm ³ (0.2–0.3 US oz, 0.2–0.4 Imp.oz).
					Spring	Replace with stiff spring.
Stiff toward stroke end	√				Oil amount	Decrease oil amount by about 5 cm ³ (0.2 US oz, 0.2 Imp.oz).
Soft toward stroke end, bottoming out	√				Oil amount	Increase oil amount by about 5 cm ³ (0.2 US oz, 0.2 Imp.oz).
Stiff initial movement	√	√	√	√	Compression damping force	Turn adjuster counterclockwise (about 2 clicks) to decrease damping.

Symptom	Section				Check	Adjust
	Jump	Large gap	Medium gap	Small gap		
Low front, tending to lower front posture			√	√	Compression damping force	Turn adjuster clockwise (about 2 clicks) to increase damping.
					Rebound damping force	Turn adjuster counterclockwise (about 2 clicks) to decrease damping.
					Balance with rear end	Set sunken length for 95–100 mm (3.7–3.9 in) when one passenger is astride seat (lower rear posture).
					Oil amount	Increase oil amount by about 5 cm ³ (0.2 US oz, 0.2 Imp.oz).
“Obtrusive” front, tending to upper front posture			√	√	Compression damping force	Turn adjuster counterclockwise (about 2 clicks) to decrease damping.
					Balance with rear end	Set sunken length for 90–95 mm (3.5–3.7 in) when one passenger is astride seat (upper rear posture).
					Spring	Replace with soft spring.
					Oil amount	Decrease oil amount by about 5–10 cm ³ (0.2–0.3 US oz, 0.2–0.4 Imp.oz).

EAM30180

SUSPENSION SETTING (REAR SHOCK ABSORBER)

TIP

- If any of the following symptoms is experienced with the standard position as the base, make resetting by reference to the adjustment procedure given in the same chart.
- Adjust the rebound damping in 2-click increments or decrements.
- Adjust the low compression damping in 1-click increments or decrements.
- Adjust the high compression damping in 1/6 turn increments or decrements.

Symptom	Section				Check	Adjust
	Jump	Large gap	Medium gap	Small gap		
Stiff, tending to sink			√	√	Rebound damping force	Turn adjuster counterclockwise (about 2 clicks) to decrease damping.
					Spring set length	Set sunken length for 90–100 mm (3.5–3.9 in) when one passenger is astride seat.
Spongy and unstable			√	√	Rebound damping force	Turn adjuster clockwise (about 2 clicks) to increase damping.
					Low compression damping	Turn adjuster clockwise (about 1 click) to increase damping.
					Spring	Replace with stiff spring.

CHASSIS

Symptom	Section				Check	Adjust
	Jump	Large gap	Medium gap	Small gap		
Heavy and dragging			√	√	Rebound damping force Spring	Turn adjuster counterclockwise (about 2 clicks) to decrease damping. Replace with soft spring.
Poor road gripping				√	Rebound damping force Low compression damping High compression damping Spring set length Spring	Turn adjuster counterclockwise (about 2 clicks) to decrease damping. Turn adjuster clockwise (about 1 click) to increase damping. Turn adjuster clockwise (about 1/6 turn) to increase damping. Set sunken length for 90–100 mm (3.5–3.9 in) when one passenger is astride seat. Replace with soft spring.
Bottoming out	√	√			High compression damping Spring set length Spring	Turn adjuster clockwise (about 1/6 turn) to increase damping. Set sunken length for 90–100 mm (3.5–3.9 in) when one passenger is astride seat. Replace with stiff spring.
Bouncing	√	√			Rebound damping force Spring	Turn adjuster clockwise (about 2 clicks) to increase damping. Replace with soft spring.
Stiff travel	√	√			High compression damping Spring set length Spring	Turn adjuster counterclockwise (about 1/6 turn) to decrease damping. Set sunken length for 90–100 mm (3.5–3.9 in) when one passenger is astride seat. Replace with soft spring.

WIRING DIAGRAM**YZ250F/YZ250FR 2024**

1. Crankshaft position sensor
2. AC magneto
3. Rectifier/regulator
4. Engine ground
5. Frame ground
6. Battery
7. Fuse
8. Starter relay
9. Starter motor
10. Diode 1
11. CCU (Communication Control Unit)
12. ECU (Engine Control Unit)
13. Ignition coil
14. Spark plug
15. Fuel injector
16. Fuel pump
17. Intake air temperature sensor
18. Coolant temperature sensor
19. Throttle position sensor
20. Intake air pressure sensor
21. Gear position switch
22. Handlebar switch (left)
23. Indicator light
24. Mode switch
25. Engine stop switch
26. Handlebar switch (right)
27. Start switch

- A. Wire harness
- B. CCU sub-lead

COLOR CODE

B	Black
Br	Brown
DI	Dark blue
G	Green
Gy	Gray
L	Blue
P	Pink
R	Red
Sb	Sky blue
W	White
Y	Yellow
B/Br	Black/Brown
B/L	Black/Blue
B/R	Black/Red
B/W	Black/White
B/Y	Black/Yellow
Br/W	Brown/White
G/B	Green/Black
L/B	Blue/Black
Lg/L	Light green/Blue
Lg/W	Light green/White
R/B	Red/Black
R/L	Red/Blue
R/W	Red/White
R/Y	Red/Yellow
W/B	White/Black
Y/B	Yellow/Black
Y/W	Yellow/White



PRINTED IN JAPAN
(E)



Original instructions
Notice originale
Originalbetriebsanleitung
Istruzioni originali
Manual original



PRINTED IN JAPAN
2023.07-0.9×1 
(E, F, G, H, S)

YZ250F/YZ250FR 2024
WIRING DIAGRAM

YZ250F/YZ250FR 2024
SCHEMA DE CÂBLAGE

YZ250F/YZ250FR 2024
SCHALTPLAN

YZ250F/YZ250FR 2024
SCHEMA ELETTRICO

YZ250F/YZ250FR 2024
DIAGRAMA ELÉCTRICO

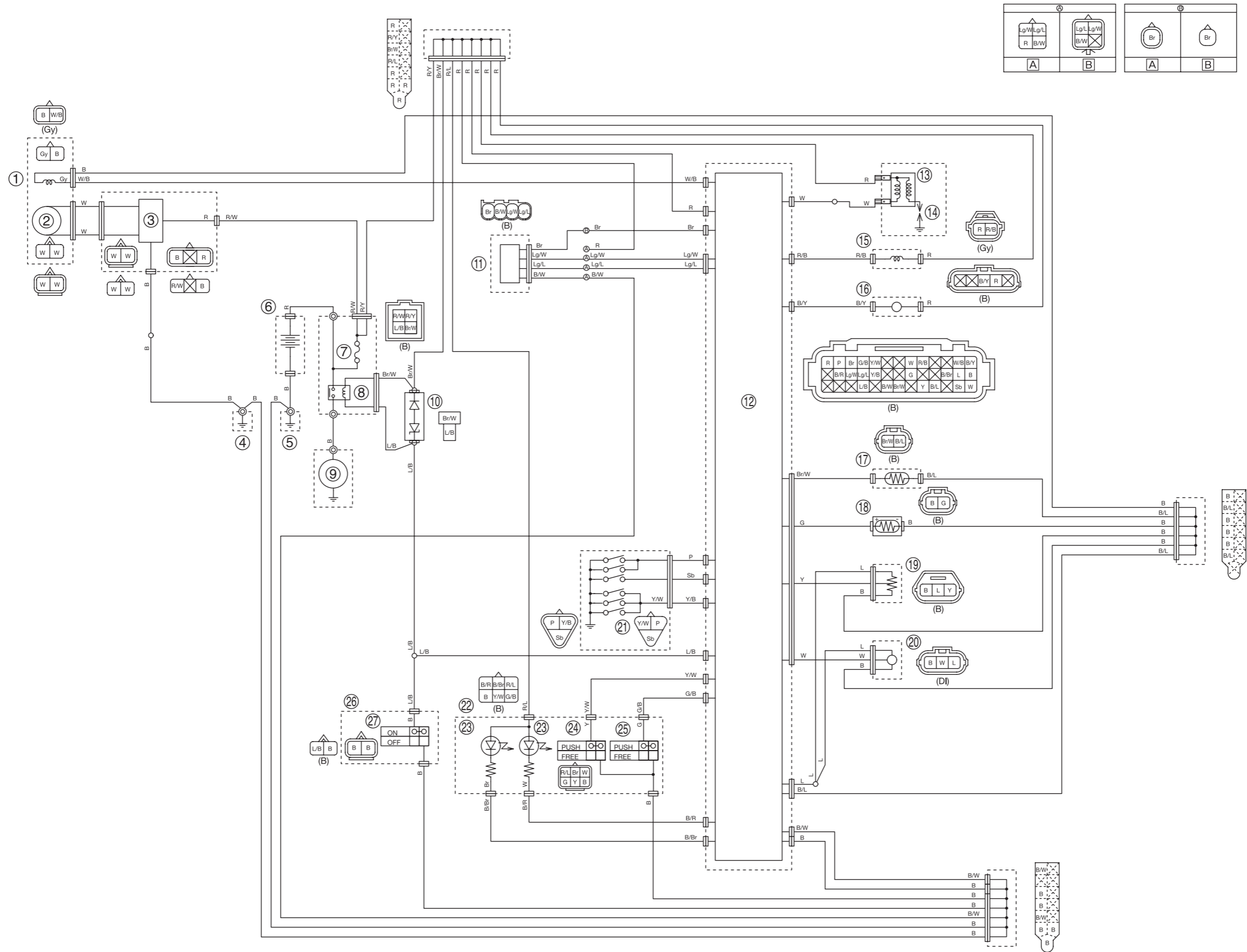

YZ250F/YZ250FR 2024
WIRING DIAGRAM

YZ250F/YZ250FR 2024
SCHEMA DE CÂBLAGE

YZ250F/YZ250FR 2024
SCHALTPLAN

YZ250F/YZ250FR 2024
SCHEMA ELETTRICO

YZ250F/YZ250FR 2024
DIAGRAMA ELÉCTRICO

