



⚠ READ THIS MANUAL CAREFULLY!
It contains important safety information.

OWNER'S MANUAL

YZF
1000R

YZF1000ET

BAS-F8199-7B

EBU33110

 **Read this manual carefully before operating this vehicle. This manual should stay with this vehicle if it is sold.**

INTRODUCTION

Congratulations on your purchase of the Yamaha YXZ1000ET. It represents the result of many years of Yamaha experience in the production of fine sporting, touring, and pace-setting racing vehicles. With the purchase of this Yamaha, you can now appreciate the high degree of craftsmanship and reliability that have made Yamaha a leader in these fields.

This manual will provide you with a good basic understanding of the features and operation of this vehicle. It also includes basic maintenance and inspection procedures. If you have any questions regarding the operation or maintenance of your vehicle, please consult a Yamaha dealer.





Please read this manual carefully before operating this vehicle. Do not attempt to operate this vehicle until you have attained adequate knowledge of its controls and operating features. Regular inspections and careful maintenance, along with good operating techniques, will help ensure that you safely enjoy the capabilities and reliability of this vehicle.

IMPORTANT MANUAL INFORMATION

FAILURE TO FOLLOW THE WARNINGS CONTAINED IN THIS MANUAL CAN RESULT IN SERIOUS INJURY OR DEATH.

Particularly important information is distinguished in this manual by the following notations:

	This is the safety alert symbol. It is used to alert you to potential personal injury hazards. Obey all safety messages that follow this symbol to avoid possible injury or death.
	A WARNING indicates a hazardous situation which, if not avoided, could result in death or serious injury.
	A NOTICE indicates special precautions that must be taken to avoid damage to the vehicle or other property.
TIP	A TIP provides key information to make procedures easier or clearer.

* Product and specifications are subject to change without notice.

IMPORTANT NOTE ABOUT USE

- **THIS MACHINE IS DESIGNED STRICTLY FOR COMPETITION USE, ONLY ON A CLOSED COURSE.**
- **This vehicle is designed and manufactured for use on UNPAVED surfaces only, for sport-type recreational use by experienced operators. It is unsafe to operate this vehicle on any paved surface, paved street, paved road or motorway.**
- **Check the laws and regulations in force before choosing where to operate this vehicle. It is illegal to operate this vehicle on public lands where vehicles its size are prohibited.**

**YXZ1000ET
OWNER'S MANUAL
©2021 by Yamaha Motor Co., Ltd.
1st edition, October 2020
All rights reserved.
Any reprinting or unauthorized use
without the written permission of
Yamaha Motor Co., Ltd.
is expressly prohibited.
Printed in U.S.A.**

CONTENTS

VEHICLE IDENTIFICATION	1-1	On-Command drive knob	
Identification numbers.....	1-1	“2WD/4WD/DIFF. LOCK”	5-21
LOCATION OF THE WARNING AND		Accelerator pedal	5-22
SPECIFICATION LABELS	2-1	Brake pedal	5-22
SAFETY INFORMATION	3-1	Parking brake lever	5-23
DESCRIPTION.....	4-1	YCC-S system.....	5-23
Left view	4-1	Drive select lever and shift paddles ...	5-24
Right view	4-2	Fuel tank cap.....	5-25
Controls and instruments.....	4-3	Doors.....	5-25
INSTRUMENT AND CONTROL		Seats	5-26
FUNCTIONS.....	5-1	Adjusting the driver seat position.....	5-27
Main switch	5-1	Adjusting the steering wheel	
Indicator lights and warning lights	5-2	position.....	5-28
Multi-function meter unit	5-10	Rearview mirror (equipped models) ...	5-29
Light switch	5-19	Seat belts	5-29
Interior light switch		Glove compartment	5-30
(equipped models).....	5-20	Storage compartments	5-30
		Cup holders.....	5-31
		Cargo bed	5-32
		Flag pole bracket	5-33
		Front shock absorbers	5-33
		Rear shock absorbers	5-41
		Auxiliary DC jack	5-48

FOR YOUR SAFETY –	
PRE-OPERATION CHECKS	6-1
Front and rear brakes	6-3
Fuel	6-3
Engine oil	6-5
Transmission	6-6
Coolant	6-6
Final gear	6-6
Differential gear	6-6
Accelerator pedal	6-6
Seat belts	6-7
Passenger handhold	6-7
Steering	6-7
Drive select lever and shift paddles	6-7
YCC-S clutch	6-8
Fittings and fasteners	6-8
Instruments, lights and switches	6-8
Control cables	6-8
Tires	6-8
OPERATION	7-1
Engine break-in	7-1
Starting the engine	7-2

Shifting and reverse driving	7-3
Dynamic clutch engagement	7-7
Launch system operation	7-7
Selecting the drive mode	7-10
Parking	7-12
Loading	7-12

BASIC GUIDE FOR SAFE USE	8-1
KNOW YOUR VEHICLE	8-1
LEARNING TO OPERATE YOUR VEHICLE	8-12

PERIODIC MAINTENANCE AND ADJUSTMENT	9-1
Owner's Manual and tool kit	9-2
Maintenance charts	9-4
Hood	9-11
Panels	9-11
Engine oil and oil filter	9-18
Why Yamalube	9-28
Transmission oil	9-29
Final gear oil	9-31
Differential gear oil	9-34

Coolant.....	9-36	Pedal lubrication.....	9-54
Axle boots	9-38	Checking the stabilizer bushes.....	9-54
Checking the spark plugs	9-38	Upper and lower arm pivot	
Air filter maintenance.....	9-40	lubrication (left and right)	9-55
Cleaning the air filter case check		Rear knuckle upper and lower pivot	
hoses	9-44	lubrication (left and right)	9-56
Cleaning the spark arrester	9-45	Drive shaft universal joint	
Valve clearance	9-47	lubrication	9-56
Brakes	9-47	Steering shaft lubrication.....	9-56
Checking the front and rear brake		Wheel removal	9-57
pads.....	9-47	Checking and tightening the bead	
Checking the parking brake pads	9-48	lock (equipped models)	9-57
Checking the brake and YCC-S		Tire replacement.....	9-58
clutch fluid levels	9-48	Wheel installation.....	9-59
Brake and YCC-S clutch fluid		Battery	9-59
replacement.....	9-50	Jump-starting	9-63
YCC-S clutch	9-50	Fuse replacement	9-64
Checking the brake pedal	9-51	Headlights.....	9-66
Checking the accelerator pedal	9-51	Headlight beam adjustment	9-67
Parking brake lever free play		Brake/tail light.....	9-68
adjustment.....	9-52	Interior lights (equipped models)	9-68
Brake light switch.....	9-53	Troubleshooting.....	9-68
Cable inspection and lubrication.....	9-53	Troubleshooting charts.....	9-69

CLEANING AND STORAGE	10-1
Cleaning	10-1
Storage.....	10-2
SPECIFICATIONS	11-1
CONSUMER INFORMATION	12-1
Vehicle data recording	12-1
INDEX.....	13-1

VEHICLE IDENTIFICATION

1

EBU33321

Identification numbers

Record the vehicle identification number and model label information in the spaces provided below.

VEHICLE IDENTIFICATION NUMBER:

MODEL LABEL INFORMATION:

EBU32800

Vehicle identification number

The vehicle identification number is stamped into the frame.

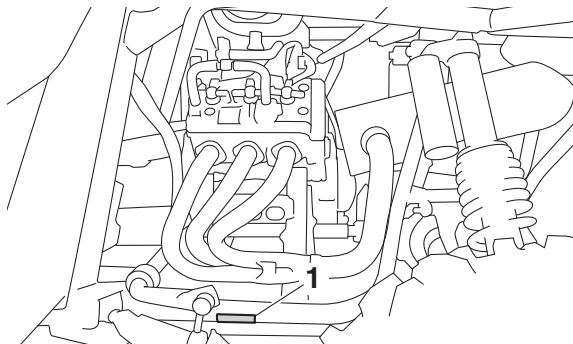

1. Vehicle identification number

The vehicle identification number is used to identify your vehicle.

EBU32811

Model label

The model label is affixed at the location shown.

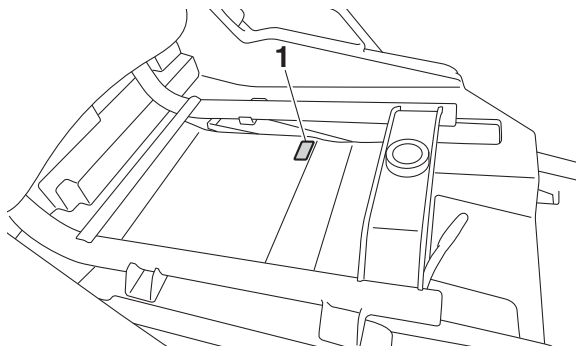

1. Model label

Your specific model can be identified by checking the model type code found on the model label.

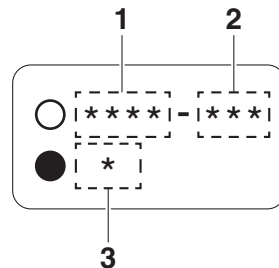

- 1. Model type code
- 2. Production code
- 3. Color code

LOCATION OF THE WARNING AND SPECIFICATION LABELS

2

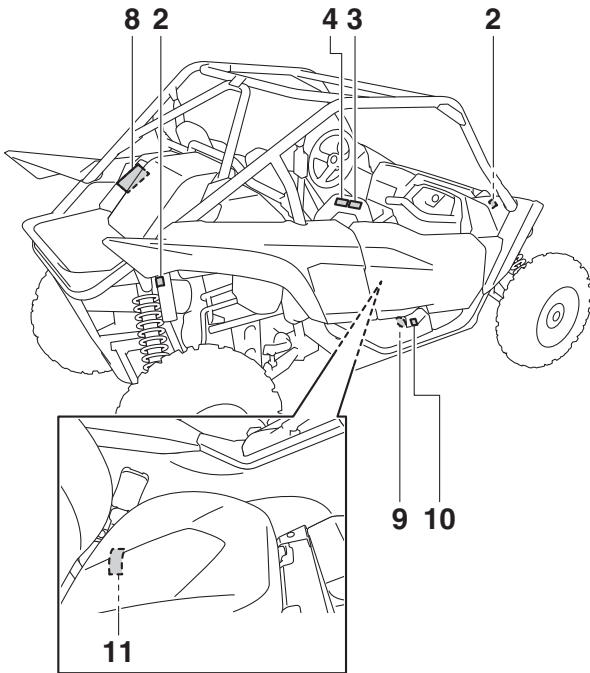
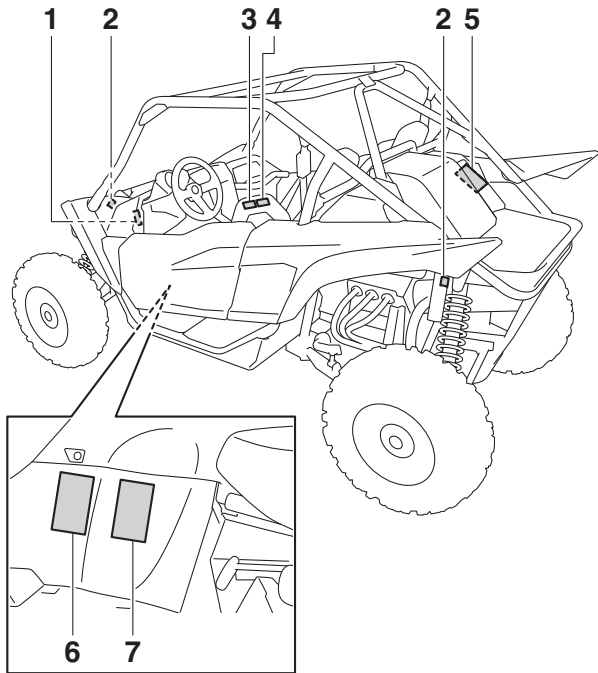

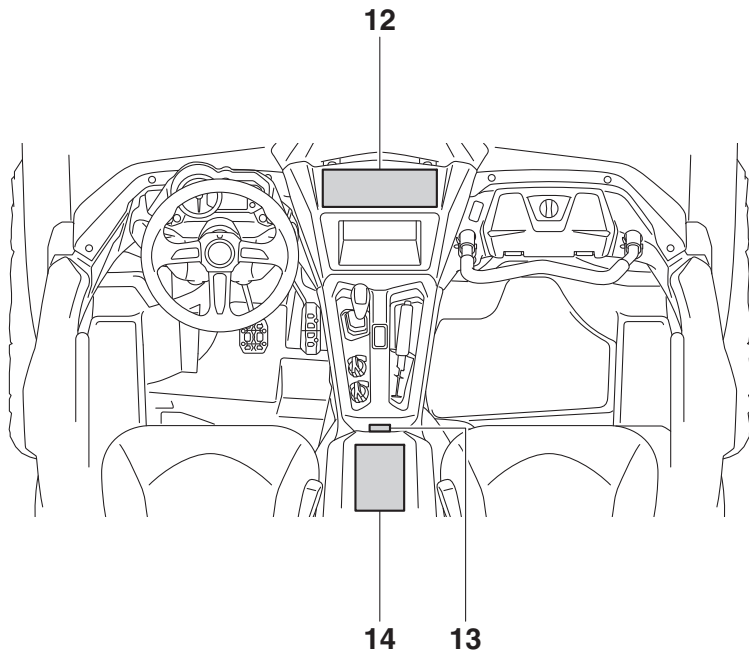

Read and understand all of the labels on your vehicle. They contain important information for safe and proper operation of your vehicle.

2

Never remove any labels from your vehicle. If a label becomes difficult to read or comes off, a replacement label is available from your Yamaha dealer.

1

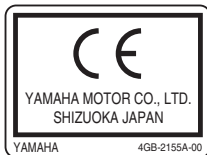

2



2

3



4



5

⚠ AVERTISSEMENT

Aucun passager
dans la caisse de
chargement



Le mauvais usage de la caisse de chargement ou de l'arceau de protection peut provoquer de graves blessures ou la mort par suite d'une perte de contrôle, d'un capotage ou d'un accident quelconque.

Charge maximale dans la caisse : 136 kg (300 lbs)
Charge maximale du véhicule : 328 kg (723 lbs)

La charge peut affecter la maniabilité et la stabilité du véhicule.

- Ne pas dépasser la capacité de charge maximale pour la benne ou le véhicule.
- Arrimer solidement toute charge – un article mal arrimé pourrait nuire soudainement à la maniabilité ou être projeté vers l'avant et heurter un occupant.
- Répartir le poids de la charge de façon équilibrée et le plus bas possible dans la caisse; une charge mal équilibrée augmente le risque de capotage.

Lors du transport d'une charge :

- Réduire la vitesse et prévoir une distance de freinage accrue.
 - Négocier les virages progressivement et lentement.
 - Éviter les pentes et les terrains accidentés.
- Lire le manuel du propriétaire avant de charger la benne.

BAS-F4897-30

6

⚠ AVERTISSEMENT

- Une pression de gonflage incorrecte des pneus ou la surcharge du véhicule risquent de provoquer une perte de contrôle ou un capotage, entraînant des blessures, voire la mort.
- Ne jamais régler la pression de gonflage ni la laisser baisser sous le seuil minimal; le pneu risque de se déjanter.

PRESSIION DE SERVICE DES PNEUS : Régler les pneus à froid.

- CHARGE DU VÉHICULE : de 0 kg (0 lbs) à 195 kg (430 lbs)
Recommandation: AVANT: 114 kPa (16.5 psi)
ARRIÈRE: 128 kPa (18.5 psi)
Minimum: AVANT: 110 kPa (16 psi)
ARRIÈRE: 124 kPa (18 psi)
- CHARGE DU VÉHICULE : de 195 kg (430 lbs) à 328 kg (723 lbs)
Recommandation: AVANT: 114 kPa (16.5 psi)
ARRIÈRE: 169 kPa (24.5 psi)
Minimum: AVANT: 110 kPa (16 psi)
ARRIÈRE: 165 kPa (24 psi)

* La charge du véhicule comprend le poids du pilote, du passager, des accessoires et la charge. Ne pas dépasser la charge maximale du véhicule.

Poids nominal brut du véhicule : 1065 kg (2348 lbs)
maximum (véhicule, poids du pilote, du passager,
des accessoires et charge).

BAS-F1696-50

⚠ WARNING

- Improper tire pressure or overloading this vehicle may cause severe injury or death from loss of control or rollover.
- Never set or allow tire pressure to be below the minimum. Tire may dislodge from rim.

OPERATING TIRE PRESSURE: With tires cold, set as follows.

- **VEHICLE LOAD of 0 lb (0 kg) ~ 430 lbs (195 kg)**
 Recommended: FRONT: 16.5 psi (114 kPa)
 REAR: 18.5 psi (128 kPa)
 Minimum: FRONT: 16 psi (110 kPa)
 REAR: 18 psi (124 kPa)
- **VEHICLE LOAD of 430 lbs (195 kg) ~ 723 lbs (328 kg)**
 Recommended: FRONT: 16.5 psi (114 kPa)
 REAR: 24.5 psi (169 kPa)
 Minimum: FRONT: 16 psi (110 kPa)
 REAR: 24 psi (165 kPa)

* Vehicle load is weight of operator, passenger, accessories, and cargo. Do not exceed maximum vehicle load.

Gross Vehicle Weight Rating: 2348 lbs (1065 kg) maximum including vehicle, weight of operator, passenger, accessories, and cargo.

BAS-F1696-30

⚠ WARNING

Improper use of cargo bed or cage/frame can result in severe injury or death from loss of control, overturn or other accidents.

Never carry passengers in cargo bed.



Maximum Load in Cargo Bed: 300 lbs (136 kg)
 Maximum Vehicle Load: 723 lbs (328 kg)

- Load may affect handling and stability.
 - Do not exceed the maximum load ratings for the cargo bed, or vehicle.
 - Secure cargo so that it will not shift - a loose load could change handling unexpectedly or be thrown forward and strike occupants.
 - Keep weight in the cargo bed centered side to side and as low as possible. Top-heavy loads increase the risk of a rollover.
- When loaded with cargo:
 - Reduce speed and allow more room to stop.
 - Turn gradually and slowly.
 - Avoid hills and rough terrain.
- Read Owner's Manual before loading cargo bed.

BAS-F4897-20

2

9







10

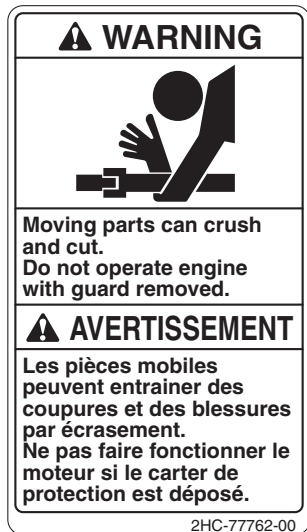

11



⚠ WARNING	
<p style="text-align: center;">Improper Use of Off-Highway Vehicles Can Cause Severe Injury or Death</p> <p>Drive Responsibly Avoid loss of control and rollovers:</p> <ul style="list-style-type: none"> • Avoid abrupt maneuvers, sideways sliding, skidding, or fishtailing, and never do donuts. • Slow down before entering a turn. • Avoid hard acceleration when turning, even from a stop. • Plan for hills, rough terrain, ruts, and other changes in traction and terrain. • Avoid paved surfaces. • Avoid side hilling (riding across slopes). • Do not allow anyone to ride in the cargo bed. <p>Rollovers have caused severe injuries and death, even on flat, open areas.</p> 	<p style="text-align: center;">Require Proper Use of Your Vehicle Do your part to prevent injuries:</p> <ul style="list-style-type: none"> • Do not allow careless or reckless driving. • Make sure operators are 16 or older with valid driver's license. • Do not let people drive or ride after using alcohol or drugs. • Do not allow operation on public roads (unless designated for off-highway vehicle access) – collisions with cars and trucks can occur. • Do not exceed seating capacity: 1 passenger. <p>Read Owner's Manual Read Tips Guide for Recreational Off-Highway Vehicle Driver Follow All Instruction and Warnings</p> <div style="text-align: center;">  </div>
	<p style="text-align: center;">⚠ WARNING</p> <p>Improper Use of Off-Highway Vehicle Can Cause Severe Injury or Death</p> <p>Be Prepared</p> <ul style="list-style-type: none"> • Fasten seat belts. • Wear an approved helmet, eye protection and protective gear. • Driver must be able to comfortably reach all controls while sitting upright with back against seat. • Passengers must be able to reach the handhold while keeping feet flat on floor and sitting upright with back against seat. • Stay completely inside the vehicle. <p>Pay Attention and Plan Ahead If you think or feel the vehicle may tip or roll, reduce your risk to injury:</p> <ul style="list-style-type: none"> • Keep a firm grip on the steering wheel or handhold and brace yourself. • Do not put any part of your body outside of the vehicle for any reason. <div style="text-align: right;">  </div>
BAS-F1568-00	





16+



BAS-F178A-00

AVERTISSEMENT

L'utilisation négligente d'un véhicule hors route peut causer de graves blessures, voire la mort.

Être préparé

- Attacher la ceinture de sécurité.
- Porter un casque homologué, une protection pour les yeux et une tenue de protection.
- Le conducteur doit pouvoir rejoindre aisément toutes les commandes alors qu'il est en position assise, son dos contre le dossier du siège.
- Les occupants doivent pouvoir rejoindre la poignée de maintien centrale alors que leurs pieds reposent à plat sur le plancher et qu'ils sont assis le dos contre le dossier du siège.
- Demeurer entièrement dans l'habitacle du véhicule.



Conduire de façon responsable

Prévenir la perte de contrôle ou les roulades :

- Éviter les manœuvres subites, glissements latéraux, dérapages, queues de poisson et zigzags; ne jamais tenter d'acrobaties.
- Ralentir avant d'entamer un virage.
- Éviter d'accélérer brusquement dans les virages, même à partir de l'arrêt.
- Être prêt pour pentes, terrains inhospitaliers, ornières, aspérités du terrain et autres facteurs réduisant la traction. Éviter les surfaces asphaltées.
- Ne pas conduire sur le flanc des pentes.
- Ne permettre à personne de prendre place dans la caisse de chargement.



Les roulades ont déjà causé des blessures graves et la mort, même sur terrain plat et sans obstacles.

Être prévoyant, être prêt

Si une roulade ou un capotage semble imminent, réduire le risque de blessures :

- Agripper fermement le volant ou la poignée de maintien et se préparer à encaisser le choc.
- Ne mettre aucune partie du corps hors du véhicule, pour quelque raison que ce soit.

Utilisation vigilante du véhicule

Faire sa part pour prévenir les blessures :

- Ne pas permettre la conduite acrobatique ou imprudente.
- S'assurer que le conducteur est âgé d'au moins 16 ans et qu'il est titulaire d'un permis de conduire valide.
- Ne permettre à personne de conduire le véhicule ou d'y prendre place après avoir consommé alcool ou drogues.
- Ne pas permettre la conduite du véhicule sur les chemins publics (à moins que les véhicules hors route y soient autorisés) – les collisions avec voitures et camions arrivent en un clin d'œil.
- Ne pas dépasser le nombre de places disponibles : 1 passager.



Lire le Manuel du propriétaire.

Lire le Guide de conseils à l'intention du conducteur du véhicule récréatif hors route.

Suivre toutes les directives et tous les avertissements.

BAS-F1568-10



SAFETY INFORMATION

Be a responsible owner

As the vehicle's owner, you are responsible for the safe and proper operation of your Yamaha YXZ1000ET. While understanding all parts of this manual are important for vehicle ownership, be sure to read this chapter and the instructions in Chapter 8 before operating your Yamaha YXZ1000ET. Also use these two chapters and the labels on the vehicle to instruct new operators and passengers. Do not allow anyone else to operate your vehicle or ride as a passenger if you are unsure whether he or she is willing and able to follow these instructions.

Get to know your vehicle

This off-road vehicle will handle and maneuver differently from cars, ATVs, go-carts, golf-cars and grounds-keeping vehicles. Follow these instructions to reduce your risk of an accident and to reduce the risk of serious injury or death in the event of an accident.

Before you operate your Yamaha YXZ1000ET

- Prepare yourself and your passenger:
 - This vehicle is intended for use only by an operator 16 or older with a valid motor vehicle license. Check country laws for minimum age requirements.



- This vehicle is designed to carry the driver and one passenger. Never carry passengers in the cargo bed.
- Both driver and passenger should wear seat belts properly.
- Both driver and passenger must be able to put both feet flat on the floorboard while seated upright with their backs against the backrests. Passenger must be able to reach and hold the passenger handhold in front of them.
- Both driver and passenger should wear an approved motorcycle helmet that fits properly. Both driver and passenger should also wear eye protection (goggles or a face shield), gloves, over-the-ankle boots, long-sleeved shirt or jacket, and long pants.

- Do not drive or ride as passenger after using drugs or alcohol.

Prepare your vehicle

Perform the pre-operation checks each time you use the vehicle to make sure it is in safe operating condition. Failure to inspect or maintain the vehicle properly increases the possibility of an accident or equipment damage. See page 6-1 for a list of pre-operation checks.

3

Prepare your load

Carrying heavy or over-sized loads can affect handling, stability, and cause the risk of overturns or other accidents.

- Read “Loading” on page 7-12 before loading the cargo bed.
- Do not overload the vehicle or cargo bed.
- Refer to the labels on the vehicle for specific loading limits and recommended tire air pressure.
- Keep heavier objects and the load in general centered side to side, and as low and as far forward in the cargo bed as possible.
- Secure cargo so that it will not shift – a loose load could change handling unexpectedly or be thrown forward and strike occupants.
- This vehicle is not designed to tow or pull objects. Towing a trailer or pulling another vehicle or other object will affect handling, stability, and increase the risk of overturns and accidents. Towing or pulling can also cause frame and vehicle damage.

While using your Yamaha YXZ1000ET

- Keep your body completely inside the vehicle at all times. Keep both hands on the steering wheel. Be sure the passenger is seated, belted, and holding onto the passenger handhold. Close doors before driving. Any part of your body (arms, legs, and head) outside the vehicle can be struck by objects your vehicle is passing or crushed by the vehicle itself in a rollover accident.
- Watch for branches, brush, or other hazards that could enter the vehicle.
- Abrupt maneuvers or aggressive driving, even on flat, open areas, can cause loss of control, including rollovers. The YXZ1000ET has higher ground clearance and other features to handle rugged terrain, and, as a result, can overturn in situations where some other vehicles may not.
- Avoid rollovers:
 - Use care when turning:
 - Turning the steering wheel too far or too fast can result in a rollover.
 - Avoid sideways sliding, skidding, or fishtailing (rear-wheel sliding), and never do donuts.
 - Slow down before entering a turn and avoid hard braking in a turn.
 - When making tight turns from a stop or at slow speeds, avoid sudden or hard acceleration.

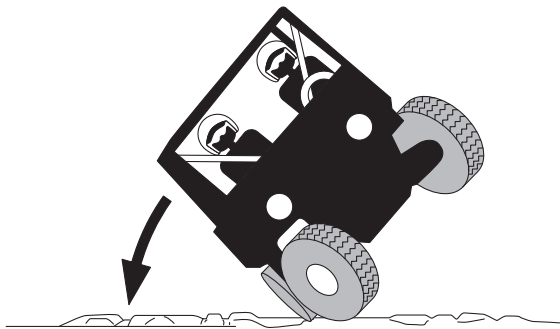

- Drive straight up and down inclines, not across them. If crossing a hill is unavoidable, drive slowly and turn downhill immediately if you feel the vehicle may tip.
- Avoid paved surfaces. Turn gradually and go slowly if you must drive on pavement. This vehicle is designed for off-road use only.
- If you think or feel that the vehicle may tip or roll, keep your body completely inside the protective structure of the vehicle:
 - Brace yourself by pressing your feet firmly on the floorboard and keep a firm grip on the steering wheel or passenger handhold.
 - Do not put your hands or feet outside of the vehicle for any reason. Your arm or leg could be crushed.
 - Do not try to stop a vehicle tipover using your arm or leg.
- Do not operate this vehicle on any public street, road, or highway, even if dirt or gravel.

- Do not operate the vehicle in fast-flowing water or water deeper than 40 cm (16 in). If you must cross shallow, slow-moving water, choose your path carefully to avoid sharp drop-offs, large rocks, or slippery surfaces. Operating this vehicle through deep or fast-flowing water can lead to loss of control or overturn. To reduce your risk of drowning or other injuries, use care when crossing through water.
- When loaded with cargo:
 - Drive more slowly than normal and allow more room to stop.
 - Avoid hills and rough terrain. Use caution when carrying a load up or downhill.

Avoid carbon monoxide poisoning

All engine exhaust contains carbon monoxide, a deadly gas. Breathing carbon monoxide can cause headaches, dizziness, drowsiness, nausea, confusion, and eventually death.

Carbon monoxide is a colorless, odorless, tasteless gas which may be present even if you do not see or smell any engine exhaust. Deadly levels of carbon monoxide can collect rapidly and you can quickly be overcome and unable to save yourself. Also, deadly levels of carbon monoxide can linger for hours or days in enclosed or poorly-ventilated areas. If you experience any symptoms of carbon monoxide poisoning, leave the area immediately, get fresh air, and **SEEK MEDICAL TREATMENT**.

- Do not run engine indoors. Even if you try to ventilate engine exhaust with fans or open windows and doors, carbon monoxide can rapidly reach dangerous levels.
- Do not run engine in poorly ventilated or partially enclosed areas such as barns, garages, or carports.

- Do not run engine outdoors where engine exhaust can be drawn into a building through openings such as windows and doors.

Genuine Yamaha Accessories

Choosing accessories for your YXZ1000ET is an important decision. Genuine Yamaha Accessories, which are available only from a Yamaha dealer, have been designed, tested, and approved by Yamaha for use on your YXZ1000ET.

Many companies with no connection to Yamaha manufacture parts and accessories or offer other modifications for Yamaha vehicles. Yamaha is not in a position to test the products that these aftermarket companies produce. Therefore, Yamaha can neither endorse nor recommend the use of accessories not sold by Yamaha or modifications not specifically recommended by Yamaha, even if sold and installed by a Yamaha dealer.

Aftermarket parts, accessories, and modifications

While you may find aftermarket products similar in design and quality to genuine Yamaha Accessories, recognize that some aftermarket accessories or modifications are not suitable because of potential safety hazards to you or others. Installing aftermarket products or having other modifications performed to your YXZ1000ET that change any of the vehicle's design or operation characteristics can put you and others at greater risk of serious injury or death. You are responsible for injuries related to changes in the vehicle.

Aftermarket tires and rims

The tires and rims that came with your YXZ1000ET were designed to match the performance capabilities and to provide the best combination of handling, braking, and comfort. Other tires, rims, sizes, and combinations may not be appropriate. Refer to page 9-58 for tire specifications and more information on replacing your tires.

DESCRIPTION

Left view

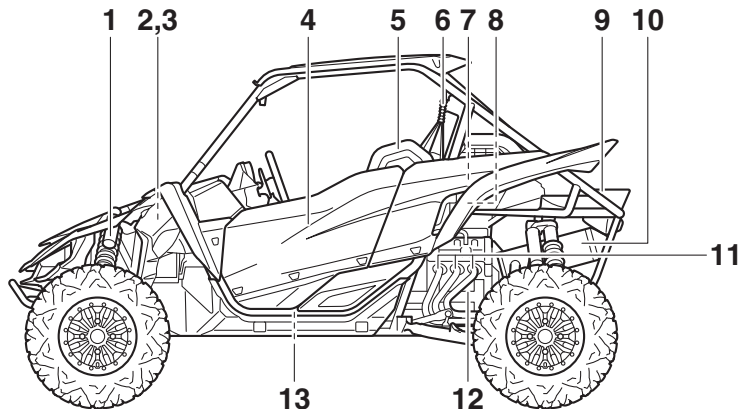

- 1. Front shock absorber
- 2. Brake fluid reservoir
- 3. YCC-S clutch fluid reservoir
- 4. Door
- 5. Shoulder bolster
- 6. Driver seat belt
- 7. Coolant reservoir

- 8. Air filter
- 9. Cargo bed
- 10. Muffler
- 11. Exhaust pipe
- 12. Engine
- 13. Transmission

Right view

4

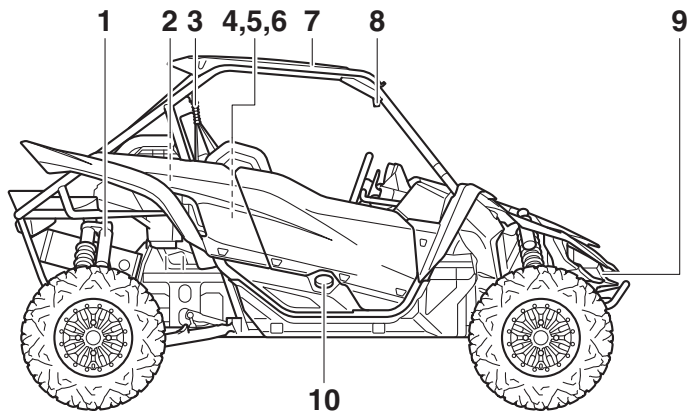

1. Rear shock absorber
2. Engine oil tank
3. Passenger seat belt
4. Battery
5. Fuses
6. Interior light (equipped models)
7. Sun top
8. Rearview mirror (equipped models)
9. Headlight
10. Fuel tank cap

Controls and instruments

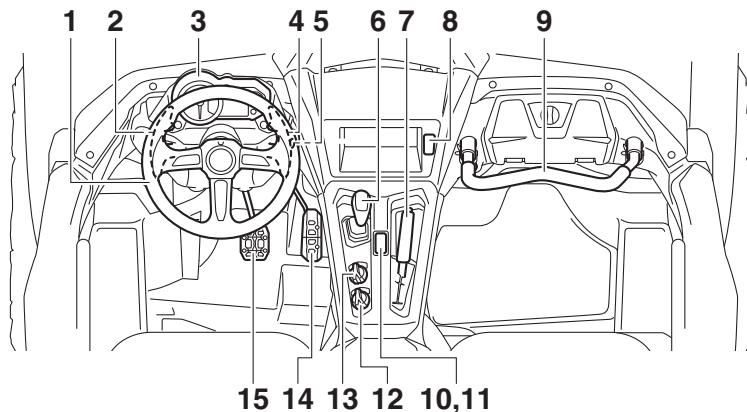

- | | |
|--|------------------------------|
| 1. Steering wheel | 9. Passenger handhold |
| 2. Shift paddle “-” | 10. Helmet reminder light |
| 3. Multi-function meter unit | 11. Seat belt reminder light |
| 4. Shift paddle “+” | 12. Light switch |
| 5. Main switch | 13. On-Command drive knob |
| 6. Drive select lever | 14. Accelerator pedal |
| 7. Parking brake lever | 15. Brake pedal |
| 8. Interior light switch (equipped models) | |

The vehicle you have purchased may differ slightly from those shown in the figures of this manual.

INSTRUMENT AND CONTROL FUNCTIONS

Main switch

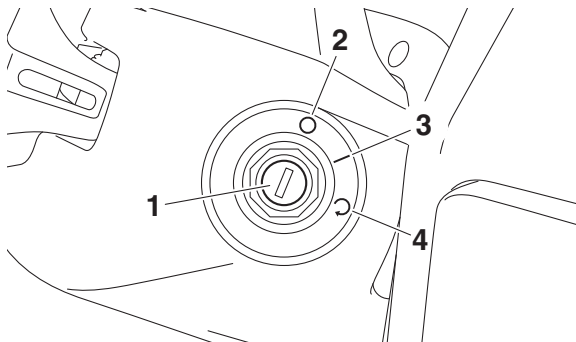

1. Main switch
2. Off position “○”
3. On position “|”
4. Start position “↻”

On position “|”

All electrical circuits are supplied with power.
The key cannot be removed.

TIP _____

The operation of the indicator and warning lights, and the multi-function meter can be confirmed at this time.

Off position “○”





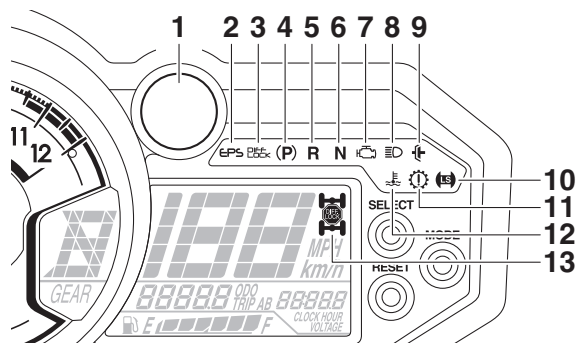

All electrical circuits are switched off. The key can be removed.

Start position “↻”



The electric starter is engaged by turning and holding the key in this position. Release the key when the engine starts.

Indicator lights and warning lights

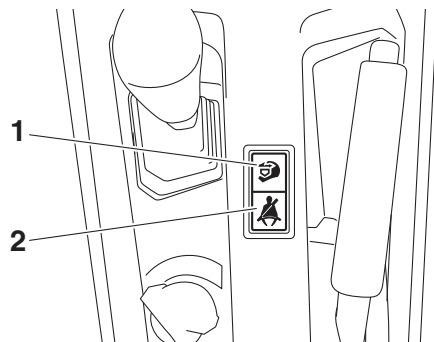

1. Shift light
2. Electric Power Steering warning light “EPS”
3. Differential gear lock indicator light “DIFF. LOCK”
4. Parking brake indicator light “(P)”
5. Reverse indicator light “R”
6. Neutral indicator light “N”
7. Engine trouble warning light “”
8. High beam indicator light “”
9. Half clutch indicator light “”
10. Launch system indicator light “”
11. YCC-S system warning light “”
12. Coolant temperature warning light “”
13. Drivetrain icon “”



1. Helmet reminder light “”
2. Seat belt reminder light “”

EBU35450

Neutral indicator light “N”

This indicator light comes on when the transmission is in the neutral position.

EBU35460

Reverse indicator light “R”

This indicator light comes on when the transmission is in the reverse position.

EBU34910

Parking brake indicator light “(P)”

This indicator light comes on when the parking brake is applied.

EBU36450

High beam indicator light “”

This indicator light comes on when the high beam of the headlight is switched on.

5

EBU37221

Differential gear lock indicator light “DIFF. LOCK”



This indicator light comes on when the front differential gear is locked.

TIP _____

When the On-Command drive knob is set to “DIFF. LOCK”, the indicator light will flash until the differential is locked. Turn the steering wheel back and forth or drive slowly to help the differential gear lock to engage.

EBU34922

Drivetrain icon “”

The drivetrain icon indicates what type of drive mode is currently selected. When 2WD is selected, the icon will turn off. When 4WD is selected, “” is displayed. And when 4WD with differential lock is selected “” is displayed.

TIP _____

- See pages 5-21 and 7-10 for more information on selecting the drive mode.
- Due to the synchronizing mechanism in the differential gear case, the drivetrain icon may not come on until the vehicle starts moving.
- When the On-Command drive knob is set to “DIFF. LOCK” or “4WD”, the drivetrain icon and the differential gear lock indicator light will flash until the differential gear is completely locked or unlocked. If the icon and the indicator light continue to flash, the differential is not completely locked or unlocked. In this case, start moving slowly

and/or turn the steering wheel back and forth to help the differential to lock or unlock.

EBU34932

Shift light

This light can be set to come on and go off at the desired engine speeds and is used to inform the driver when it is time to upshift.

The electrical circuit of the shift light can be checked by turning the key to “ I ” (on). If the light does not come on initially when the key is turned to “ I ” (on), or if the light remains on, have a Yamaha dealer check the electrical circuit.

TIP

See page 5-16 for an explanation of how to set the shift light.

EBU35283

Coolant temperature warning light “ 水 ”

This warning light comes on when the coolant temperature, and therefore the engine, is outside its normal operating temperature range.

The warning light comes on in blue to inform the driver that the vehicle should be warmed up. After the engine is started, warm it up until the warning light goes off.

The vehicle can be operated normally when the warning light is off.

The warning light comes on in red when the engine is overheating. If the red light comes on, stop the vehicle as soon as it is safe to do so and allow the engine to idle for about 10 minutes. If the warning light does not go off, stop the engine and allow it to cool. (See page 9-70.)

TIP

- If you continue to drive the vehicle while the engine is overheating, a buzzer will sound.

- The coolant temperature warning light can be checked by turning the key to “ I ” (on). The warning light should come on in purple briefly (which confirms that both the blue and red indicators are okay) and then go off. If the warning light does not come on at all, comes on in red or blue, or if the warning light remains on, have a Yamaha dealer check the vehicle.

ECB02040

NOTICE

- **The engine may overheat if the vehicle is overloaded. If this happens, reduce the load to specification.**
- **After restarting, make sure that the warning light is out. Continuous use while this warning light is on may cause damage to the engine.**

EBU31342

Engine trouble warning light “  ”

This warning light comes on or flashes if a problem is detected in the electrical circuit monitoring the engine. When this occurs, the display will indicate an error code (see page 5-18). Have a Yamaha dealer check the self-diagnostic system.

The electrical circuit of the warning light can be checked by turning the key to “ I ” (on). If the warning light does not come on initially when the key is turned to “ I ” (on), or if the warning light remains on, have a Yamaha dealer check the vehicle.

EBU33041

Electric Power Steering warning light “EPS”

This warning light comes on when the key is turned to “ I ” (on), and then goes off once the engine is started. If the warning light remains on or comes on after the engine is

started, the EPS system may not be working correctly. When this occurs, have a Yamaha dealer check the EPS system.

The electrical circuit of the warning light can be checked by turning the key to “ I ” (on). If the warning light does not come on, have a Yamaha dealer check the electrical circuit.

TIP

If the steering load is too heavy (e.g., excessive steering use at slow speed or when operating in deep mud, sand, or snow), the power assist is reduced to protect the EPS motor from overheating.

EBU36713

Half clutch indicator light “ 4 ”

This indicator light comes on to inform the driver when the clutch is partially engaged. Normal, temporary partial-engagement occurs when starting off or when shifting gears. The indicator light may also come on during engine braking or in other situations.

The electrical circuit of the indicator light can be checked by turning the key to “ I ” (on). If the indicator light does not come on and then go off, have a Yamaha dealer check the electrical circuit.

TIP

If the indicator light stays on while driving, either release the accelerator pedal or further press down the accelerator pedal (release or increase throttle) to fully engage or disengage the clutch.

ECB03351

NOTICE

Do not use the throttle (accelerator pedal) to hold the vehicle stationary when on an incline or navigating obstacles. Continuous operation while the indicator light is on may lead to shortened clutch life.

Launch system indicator light “”

This indicator light comes on when the launch system is activated. If the indicator light is flashing, either a user error or system restriction has been detected. See “Launch system operation” on page 7-7 for more information. The electrical circuit of the indicator light can be checked by turning the key to “” (on). If the indicator light does not come on and then go off, have a Yamaha dealer check the electrical circuit.

TIP

If the launch system indicator light is flashing, release the accelerator pedal and shift paddles to reset the system. When the engine speed returns to idle, the indicator light will go off. You can now start off as normal in first gear, or retry activating the launch system.

YCC-S system warning light “”

This warning light comes on when an error has occurred or a malfunction has been detected in the YCC-S system. Have a Yamaha dealer check the YCC-S system.

The electrical circuit of the YCC-S system warning light can be checked by turning the key to “” (on). If the warning light does not come on and then go off, have a Yamaha dealer check the electrical circuit.

If the YCC-S system warning light flashes when starting the engine, wait 3 seconds for the light to stop flashing, and then retry starting the engine. If an error in the YCC-S system prevents the engine from starting, the warning light will come and the display will indicate an error code.

TIP

- YCC-S system error codes are visible only when the engine is stopped.

- The engine may not start even though the starter motor operates.

If the YCC-S system stops working correctly while driving, the YCC-S warning light will come on. If this occurs, it may be impossible to shift out of the gear you are in; and the clutch may stay engaged, so a shuddering sensation may be felt when you come to a stop. Stop the vehicle on level ground safely off the main trail, and have the YCC-S system serviced by a Yamaha dealer before further operation.

TIP

If shifting into neutral is impossible using the shift paddles and drive select lever, proceed as follows if it is necessary to move the vehicle after it has stopped.

1. Turn the key to “○” (off).
2. Remove panel B (page 9-11).

3. While rocking the vehicle back and forth, push the shift rod and shift arm pivot downward (or upward if the transmission was in reverse) until the transmission is in neutral.

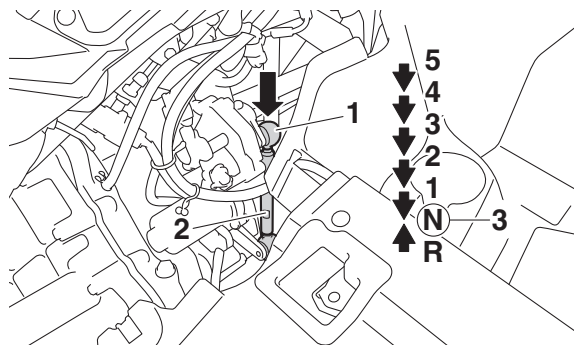

1. Shift arm pivot
2. Shift rod
3. Neutral position

EWB04171





- Turn the key to “○” (off) before attempting to manipulate the shift rod. Otherwise, the shift actuator may operate unexpectedly and cause injury.

- **Do not shift the transmission into neutral if the vehicle is stopped on an incline unless the parking brake is applied or vehicle movement is secured by other means. Otherwise, when the transmission is shifted into neutral, the vehicle may roll downhill and possibly cause an accident, serious injury or death.**

5

EBU39940

Helmet reminder light “”

The reminder light comes on and stays on while the key is turned to “” (on) to remind the occupants to always wear a helmet. If the reminder light does not come on when the key is turned to “” (on), have a Yamaha dealer check the electrical circuit.

EBU31371

Seat belt reminder light “”

The reminder light comes on when the key is turned to “” (on) to remind the occupants to fasten their seat belt. The reminder light stays on until the driver seat belt is properly

latched. If the reminder light does not come on when the key is turned to “” (on), or if the reminder light remains on after the driver seat belt is properly latched, have a Yamaha dealer check the electrical circuit.

Multi-function meter unit

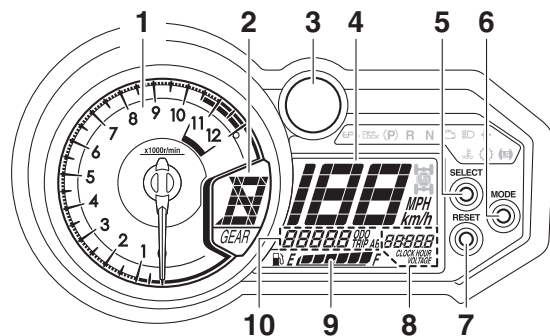

1. Tachometer
2. Transmission gear display
3. Shift light
4. Speedometer
5. "SELECT" button
6. "MODE" button
7. "RESET" button
8. Clock/Hour meter/Voltage display/Coolant temperature display
9. Fuel gauge
10. Odometer/Tripmeter A/Tripmeter B

The multi-function meter unit is equipped with the following:

- speedometer

- tachometer
- odometer
- two tripmeters
- clock
- hour meter
- voltage display
- coolant temperature display
- fuel gauge
- transmission gear display
- shift light control mode
- error code display

Speedometer

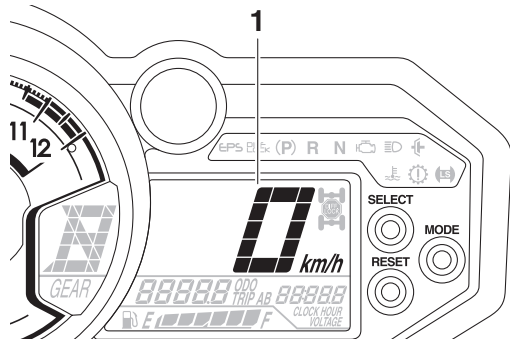

5

1. Speedometer

The speedometer shows the vehicle's traveling speed. The speedometer can be set to "MPH" or "km/h". This also changes the odometer and tripmeter units between miles and kilometers. To change the display between "MPH" and "km/h", turn the key to "○" (off), then hold the "SELECT" button pushed and turn the key to "⏏" (on).

Tachometer

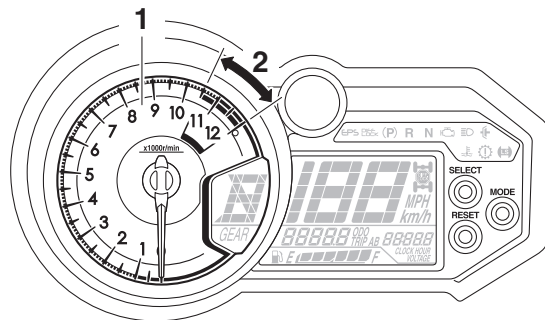

1. Tachometer

2. Tachometer red zone

The tachometer shows the engine speed in crankshaft revolutions per minute (r/min). When the vehicle is first powered on, the tachometer needle will sweep once across the r/min range and then return to zero r/min in order to test the electrical circuit.

ECB02920

NOTICE

Do not operate the engine in the tachometer red zone.

Red zone: 10500 r/min and above

Odometer and tripmeters

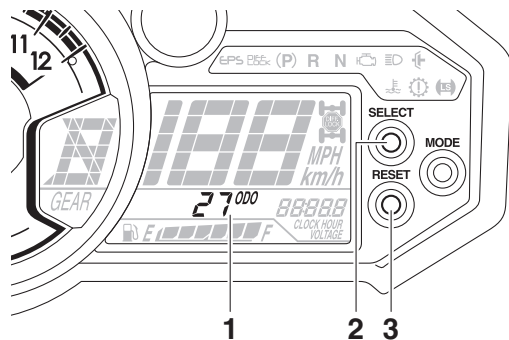

1. Odometer/Tripmeter A/Tripmeter B
2. “SELECT” button
3. “RESET” button

The odometer shows the total distance traveled by the vehicle. The odometer can be used for maintenance and service intervals. The tripmeters show the distance traveled since they were last reset. The tripmeters can be used to record the distance traveled on a single trip, or to estimate the distance that can be traveled with a full tank of gas, etc.

Push the “SELECT” button to switch between the odometer “ODO” and the tripmeters “TRIP A” and “TRIP B” in the following order: ODO → TRIP A → TRIP B → ODO

To reset a tripmeter, set the display to the tripmeter you want to reset, then push the “RESET” button until it is reset.

TIP

- The odometer will lock at 99999.
 - The tripmeters will reset and continue counting after 9999.9 is reached.
-

Clock, hour meter, voltage display and coolant temperature display

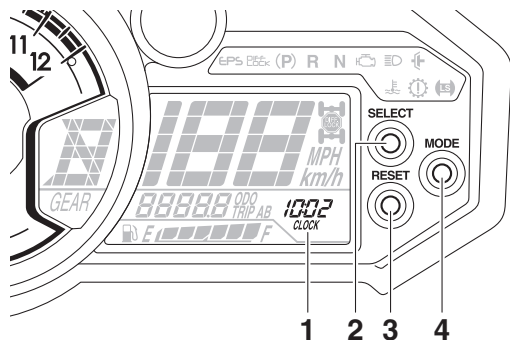

5

1. Clock/Hour meter/Voltage display/Coolant temperature display
2. “SELECT” button
3. “RESET” button
4. “MODE” button

The clock displays time in 12-hour format.

The hour meter shows the total time the engine has been running.

The voltage display shows the battery voltage.

The coolant temperature display shows the temperature of the coolant.

Push the “MODE” button to switch between the clock “CLOCK”, the hour meter “HOUR”, the voltage display “VOLTAGE”, and the coolant temperature display in the following order:

CLOCK → HOUR → VOLTAGE → coolant temperature → CLOCK

To set the clock

1. Set the display to the clock.
2. Push both the “SELECT” button and “RESET” button until the hour digits start flashing.
3. Push the “RESET” button to set the hours.
4. Push the “SELECT” button, and the minute digits will start flashing.
5. Push the “RESET” button to set the minutes.
6. Push the “SELECT” button, and then release it to start the clock.

NOTICE

If the voltage display indicates “LO” or “HI”, there may be trouble with the battery charging circuit or the battery may be faulty. If this occurs, have a Yamaha dealer check or repair the vehicle.

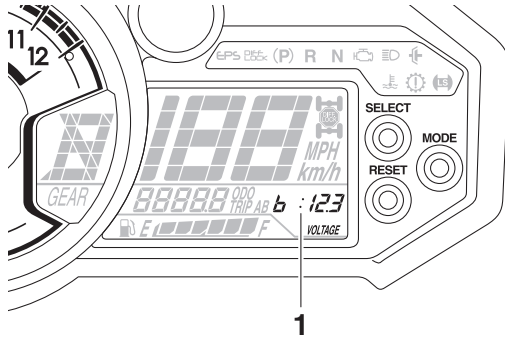
Voltage display

1. Voltage display

This display shows “ $\frac{b}{.}$ ” and the battery voltage.

When the battery voltage is low, “LO” will be displayed. When the battery voltage is high, “HI” will be displayed.

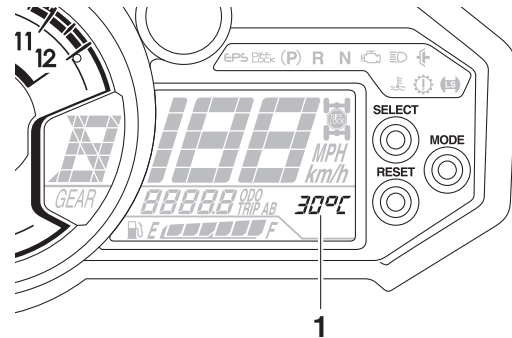
Coolant temperature display

1. Coolant temperature display

When the coolant temperature is in the normal operating range, the temperature will be displayed. When the coolant temperature is

low, “LO” will be displayed. When the coolant temperature rises, the coolant temperature display will begin to flash. If the coolant temperature continues to rise, the message “HI” will flash.

TIP

- The coolant temperature display can be set to “°C” or “°F”. To switch the temperature units, turn the key to “○” (off), then hold the “RESET” button pushed and turn the key to “□” (on).
- The radiator fans turn on and off automatically according to the coolant temperature.

Fuel gauge

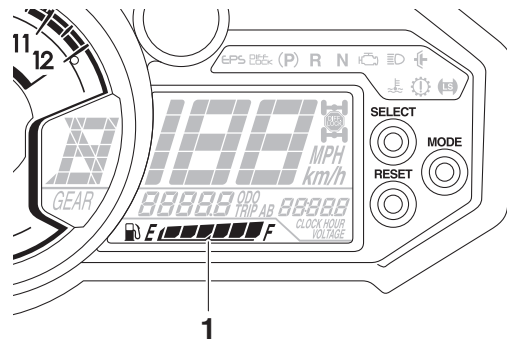

1. Fuel gauge

The fuel gauge indicates the amount of fuel in the fuel tank. The display segments of the fuel gauge disappear from “F” (full) towards “E” (empty) as the fuel level decreases. When the last segment of the fuel gauge starts flashing, refuel as soon as possible.

TIP

This fuel gauge is equipped with a self-diagnostic system. If a problem is detected in an electrical circuit, the fuel gauge will flash repeatedly. If this occurs, have a Yamaha dealer check the electrical circuit.

Transmission gear display

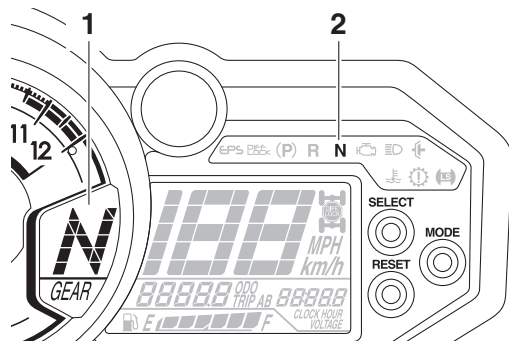

1. Transmission gear display
2. Neutral indicator light “N”

This display shows the selected gear. The neutral position is indicated by “N” and by the neutral indicator light “N”.

Shift light control mode

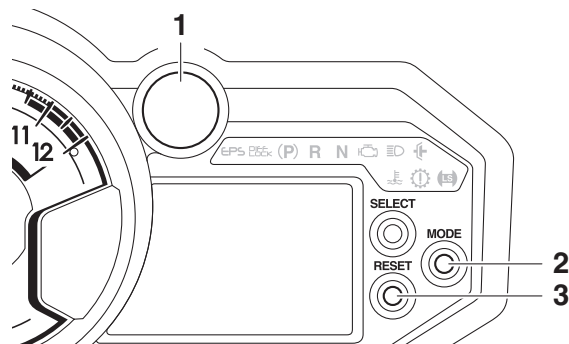

1. Shift light
2. “MODE” button
3. “RESET” button

The shift light has three settings which can be adjusted.

- **Flashing pattern:** this function allows you to choose whether or not the light will come on and whether it should flash or stay on when activated.
- **Activation point:** this function allows you to select the engine speed at which the light is activated.

- Deactivation point: this function allows you to select the engine speed at which the light is deactivated.

To enter the shift light control mode

1. Turn the key to “○” (off).
2. Push and hold the “MODE” button.
3. Turn the key to “⏏” (on), and then release the “MODE” button after all segments of the display disappear and the shift light comes on. The shift light can be adjusted as follows.

To set the flashing pattern

1. Push the “RESET” button to select one of the following flashing pattern settings:
 - On: the shift light stays on when activated. (The shift light will confirm this setting by staying on.)
 - Flash: the shift light flashes when activated. (The shift light will confirm this setting by flashing four times per second.)

- Off: the shift light is deactivated; in other words, it does not come on or flash. (The shift light will confirm this setting by flashing once every two seconds.)

2. Push the “MODE” button to confirm the selected flashing pattern. The control mode then changes to the activation point setting function. The shift light remains on and the tachometer shows the current setting r/min for the activation point.

To set the activation point

TIP

- The shift light activation point can be set between 7000 r/min and 12000 r/min. The activation point can be set in increments of 500 r/min.
- The tachometer needle will start over at 7000 r/min after 12000 r/min.

1. Push the “RESET” button to select the desired engine speed for activating the shift light.
2. Push the “MODE” button to confirm the selected engine speed. The shift light flashes and the tachometer shows the current setting r/min for the deactivation point.

To set the deactivation point



TIP

- Be sure to set the deactivation point to a higher engine speed than for the activation point, otherwise the shift light will not come on.
- The shift light deactivation point can be set between 7000 r/min and 12000 r/min. The deactivation point can be set in increments of 500 r/min.
- The tachometer needle will start over at 7000 r/min after 12000 r/min.

1. Push the “RESET” button to select the desired engine speed for deactivating the shift light.
2. Push the “MODE” button to confirm the selected engine speed. The display exits the shift light control mode and returns to the standard multi-function display mode.

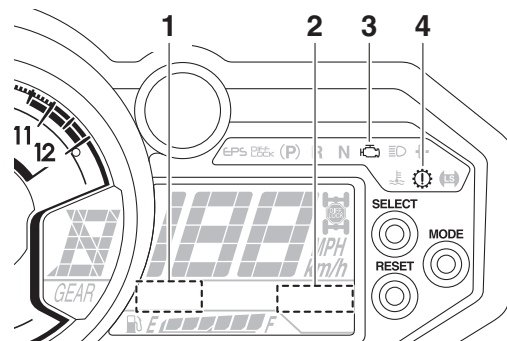
Error code display



1. Error code display
2. YCC-S system error code display
3. Engine trouble warning light “”
4. YCC-S system warning light “”

This model is equipped with a self-diagnostic device for various electrical circuits.

If a problem is detected in any of those circuits, the engine trouble warning light and/or the YCC-S system warning light will come on or flash, and the display will indicate an error code.

TIP

5

- YCC-S system error codes are displayed only when the engine is stopped.
- If the display indicates an error code, note the code number and have a Yamaha dealer check the vehicle.

ECB00812

NOTICE

If the multi-function display indicates an error code, the vehicle should be checked as soon as possible in order to avoid engine damage.

EBU35471

Light switch “○/L≡/H≡”

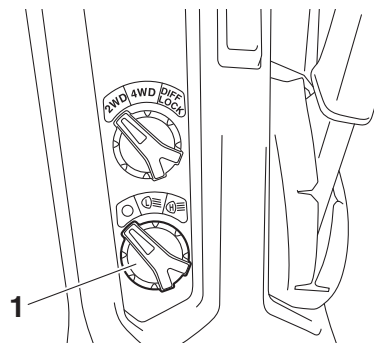

1. Light switch “○/L≡/H≡”

Set the switch to “L≡” to turn on the low beam and the taillight.

Set the switch to “H≡” to turn on the high beam and the taillight.

Set the switch to “○” to turn off the headlights and taillight.

ECB02061

NOTICE

Do not use the headlights with the engine turned off for an extended period of time. The battery may discharge to the point

that the electric starter will not have enough power to crank the engine. If this should happen, remove the battery and re-charge it.

EBU36942

Interior light switch “” (equipped models)

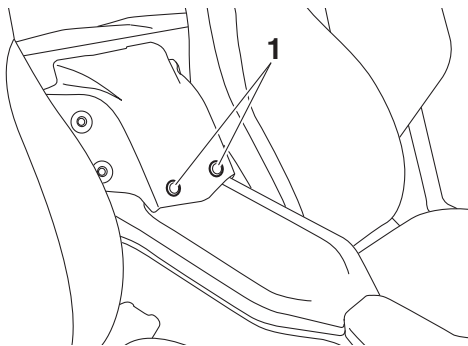

1. Interior light (equipped models)

Push the upper side (a) of the interior light switch to turn on the interior lights and push the lower side (b) of the switch to turn off the lights.

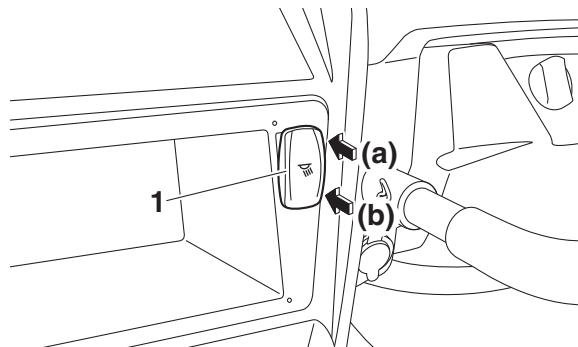

1. Interior light switch “”

On-Command drive knob “2WD/4WD/DIFF. LOCK”

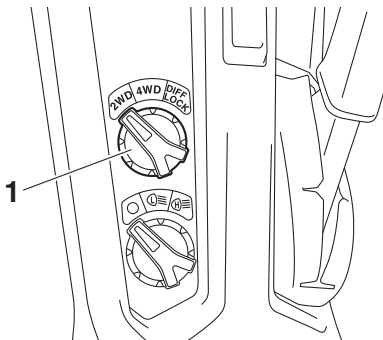

1. On-Command drive knob “2WD/4WD/DIFF. LOCK”

Stop the vehicle and move the On-Command drive knob to change the drive mode to two-wheel drive, four-wheel drive, or four-wheel drive with differential lock. Select the appropriate drive according to the terrain and driving conditions.

- “2WD” (two-wheel drive): Power is supplied to the rear wheels only.
- “4WD” (four-wheel drive): Power is supplied to the front and rear wheels.

- “DIFF. LOCK” (four-wheel drive with the differential gear locked): Power is supplied to the front and rear wheels with the differential gear locked. Unlike standard four-wheel drive, all wheels turn at the same speed regardless of traction.

TIP

Maximum vehicle speed is limited to approximately 65 km/h (40 mi/h) when “DIFF. LOCK” is selected.

Accelerator pedal

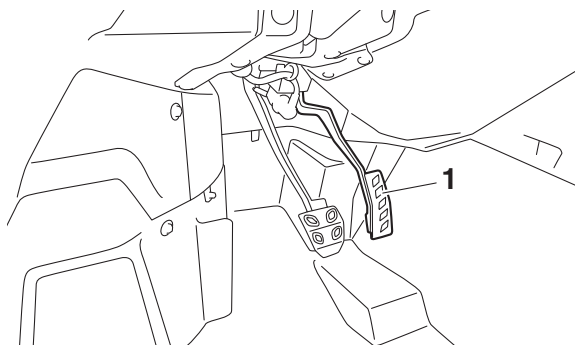

1. Accelerator pedal

Press the accelerator pedal to increase engine speed and thus vehicle speed. Release the accelerator pedal and spring tension will return the pedal to idle position.

Brake pedal

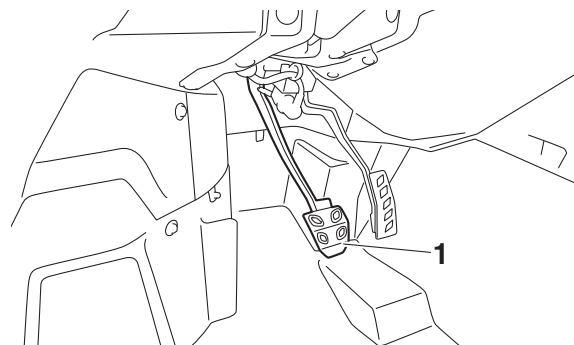

1. Brake pedal

Press the brake pedal to slow or stop the vehicle.

Parking brake lever

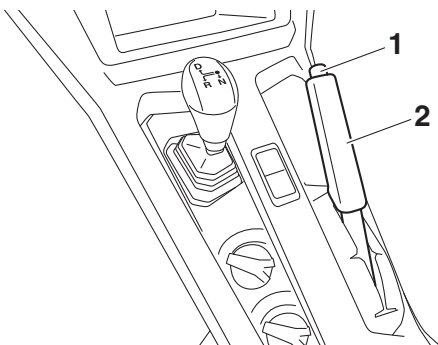

1. Release button
2. Parking brake lever

Setting the parking brake lever will help keep the vehicle from moving while parked.

To engage the parking brake, pull the lever firmly.

To release the parking brake, pull slightly on the lever, press the release button, and then push the lever to its original position.

TIP

- Spring tension helps return the lever to its original position.

- If you drive the vehicle with the parking brake engaged, a buzzer will sound.

YCC-S system

This vehicle is equipped with the Yamaha Chip Controlled-Shift system (YCC-S) with AUTO DOWNSHIFT.

YCC-S allows the driver to operate the manual transmission without having to operate the clutch. AUTO DOWNSHIFT automatically shifts the transmission into first gear when coming to a stop under normal conditions.

The transmission is operated using the drive select lever and the shift paddles. The drive select lever is used to shift the transmission into forward drive (first gear), neutral, and reverse gear. The shift paddles are used to shift through the forward gears.

When the drive select lever or shift paddles are moved, a signal is sent to the MCU (motor control unit) which disengages the clutch, the gear shift is made, and then the clutch is re-

engaged once the engine is running at proper speed. Clutch engagement is controlled by the MCU according to engine speed and other driving conditions.

TIP

- This is not an automatic transmission, only the clutch system is automatic.
 - The gears must be shifted by the driver, except when AUTO DOWNSHIFT shifts the transmission into first gear.
 - See page 7-3 for more information on shifting.
-

EBU36652

Drive select lever and shift paddles

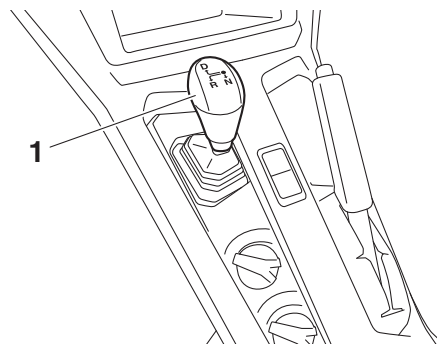

1. Drive select lever

The drive select lever is used to shift the transmission into forward drive (first gear), neutral, and reverse gear.

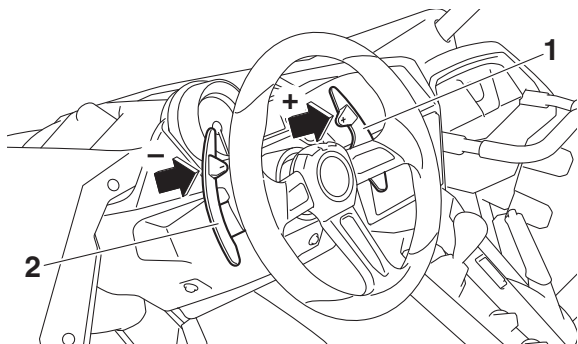

1. Shift paddle “+”
2. Shift paddle “-”

Use the shift paddles to shift through the forward gears. Pull and release the shift paddle “+” to shift up. Pull and release the shift paddle “-” to shift down.

TIP

Read “Shifting and reverse driving” for shifting instructions. (See page 7-3.)

EBU31451

Fuel tank cap

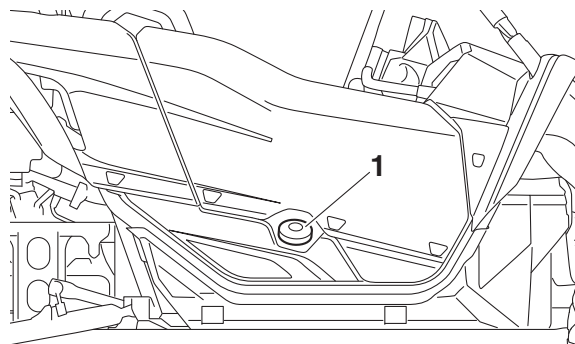

1. Fuel tank cap

Remove the fuel tank cap when refueling. To open, turn counterclockwise. When finished refueling, install the fuel tank cap by screwing it down clockwise.

EBU37390

Doors

The door handle is located on the inside of each door.

To open a door, pull the handle. To close a door, push or pull the door inward until it is securely latched. Be sure the door is **SECURELY LATCHED AFTER CLOSING IT.**

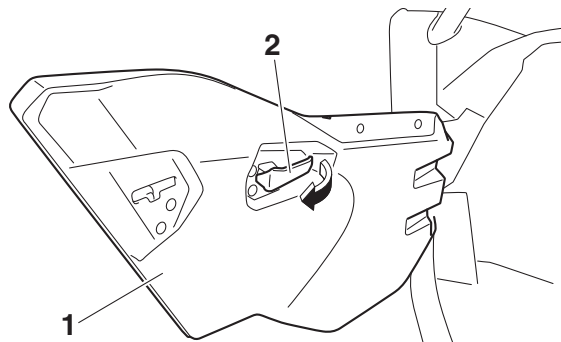

- 1. Door
- 2. Handle

EBU33461

Seats

To remove a seat cushion, lift the front of the cushion, and then pull the cushion off.



- 1. Driver seat cushion

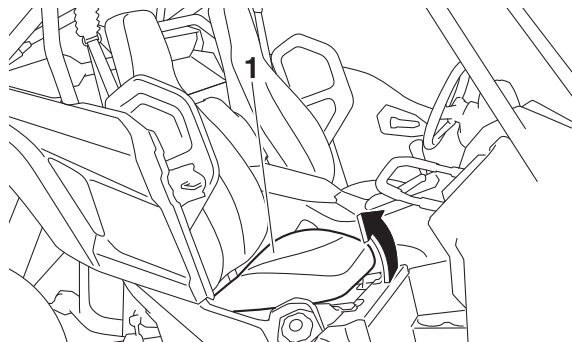

- 1. Passenger seat cushion

To install a seat cushion, insert the projections on the rear of the seat cushion under the seat frame, and then insert the projection on the front of the cushion into the grommet while pushing the cushion downward. Make sure the seats are properly secured before starting off. **WARNING! A loose seat could cause the operator to lose control, or cause the operator or passenger to fall.**

5

[EWB03510]

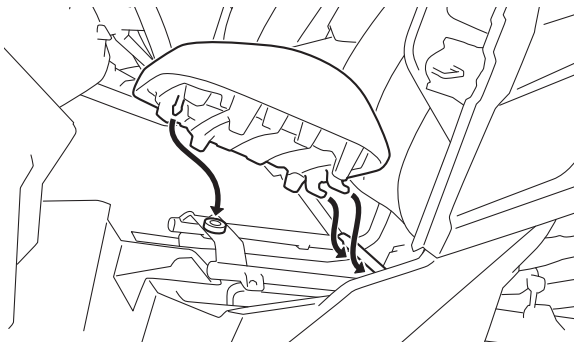

EBU34993

Adjusting the driver seat position

The driver seat position can be adjusted to suit the driver's preference. **WARNING! Never adjust the seat position while operating the vehicle, otherwise the seat may suddenly change position, which may lead to an accident.** [EWB03990]

To adjust the driver seat position, pull the driver seat position adjusting lever upward and move the seat to the desired position.

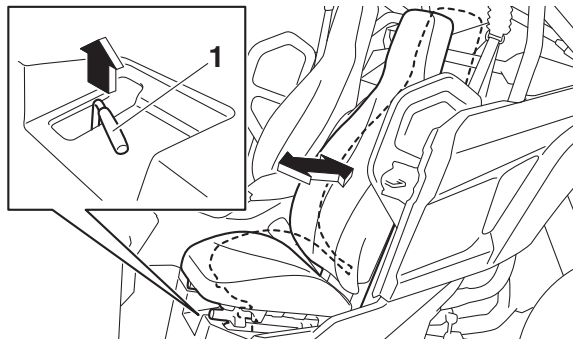

1. Driver seat position adjusting lever

TIP _____
Adjust the driver seat position and make sure it is locked in place before starting off.

EBU35002

Adjusting the steering wheel position

The steering wheel position can be adjusted to suit the driver's preference. **WARNING! Never adjust the steering wheel position while operating the vehicle, otherwise the steering wheel may suddenly change position, which may lead to an accident.** [EWB04000]

To adjust the steering wheel position, pull the steering wheel position adjusting lever and move the steering wheel to the desired position.

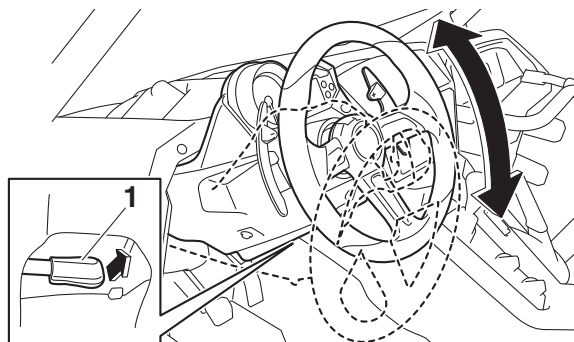

1. Steering wheel position adjusting lever

5

TIP _____
Adjust the steering wheel position before starting off.

Rearview mirror (equipped models)

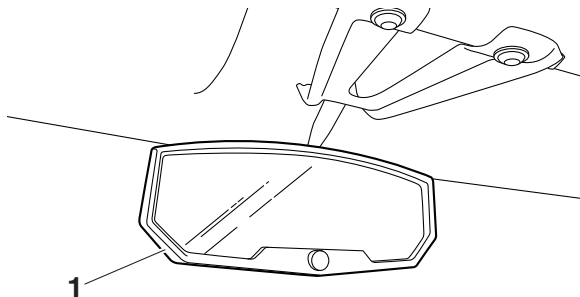

5

1. Rearview mirror (equipped models)

TIP _____
Adjust the rearview mirror before starting off.

Seat belts

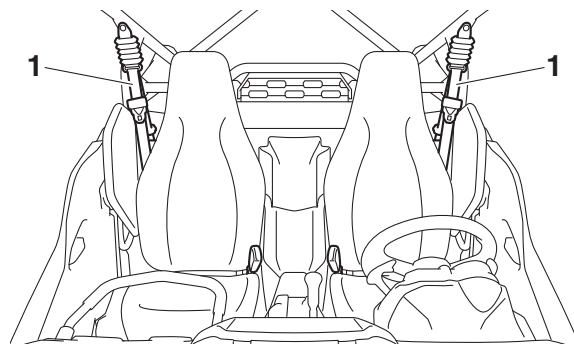

1. Seat belt

Always wear the seat belts properly while riding in the vehicle. (See page 8-5.)

TIP _____

- If the vehicle is driven without the driver seat belt fastened, a buzzer will sound.
- If the vehicle is driven without the driver seat belt fastened, engine power will be limited.

Glove compartment

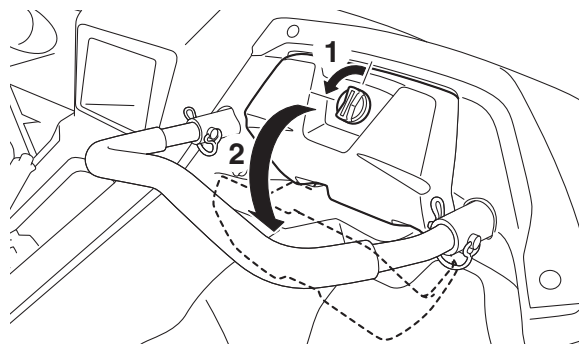

1. Unlock.
2. Open.

Store lightweight or frequently used items, such as your driving gloves or vehicle documents, in this compartment.

Glove compartment load limit: 4.5 kg (9 lb)

NOTICE

To protect from damage, do not put metal items, like tools, or sharply edged items directly in the glove compartment. If they must be stored, wrap them in appropriate cushioning material.

Storage compartments

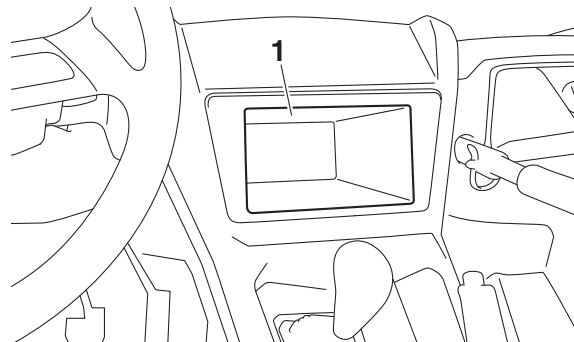

1. Storage compartment

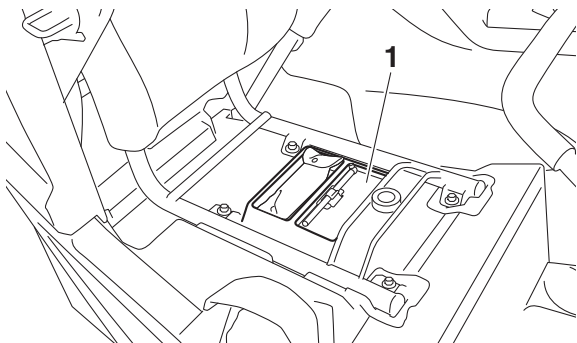

1. Storage compartment

When storing any documents in the storage compartments, be sure to wrap them in a plastic bag so that they will not get wet. When washing the vehicle, be careful not to let any water enter the storage compartments. To access the underseat storage compartment, remove the seat cushion. (See page 5-26.)

ECB02241

NOTICE

To protect from damage, do not put metal items, like tools, or sharply edged items directly in the storage compartment. If these items must be stored, wrap them in appropriate cushioning material.

EBU31520

Cup holders

Be sure to tightly close the cap of any plastic bottle before placing it in a cup holder.

Some plastic bottles may not fit into the cup holders depending on their size and shape.

EWB03240

! WARNING

- **Never ride with any open or glass containers in the cup holders; otherwise, the contents may spill and the glass containers may be thrown about and break, and possibly injure people in the vehicle during sudden braking or an accident.**

- Do not place any other items than sealable plastic containers in the cup holders; otherwise, they may be thrown about and possibly injure people in the vehicle during sudden braking or an accident.

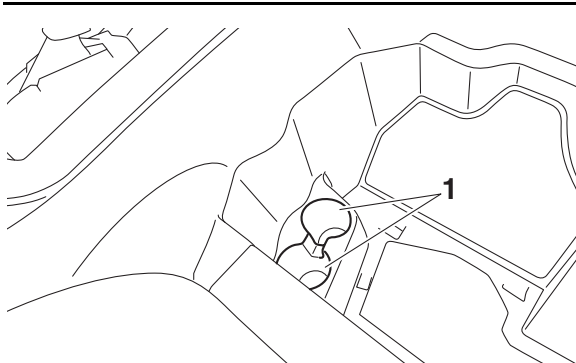

1. Cup holder

EBU35022

Cargo bed

EWB03250



WARNING

- Never carry passengers in the cargo bed.

- Do not exceed the specified maximum load limits. Heavier cargo could cause loss of control because of improper weight balance.

There are four cargo hooks in the cargo bed.

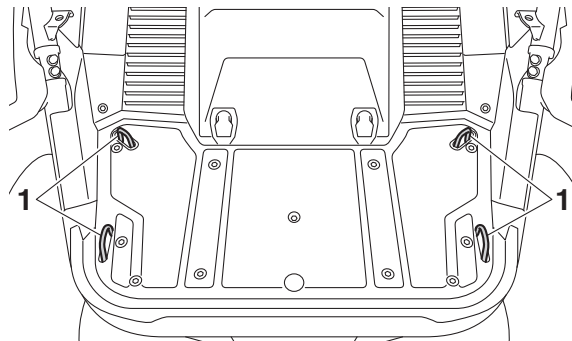

1. Cargo hook

Maximum load limit: 136.0 kg (300 lb)

For additional loading information, see page 7-12.

EBU35680

Flag pole bracket

This model is equipped with a flag pole bracket.

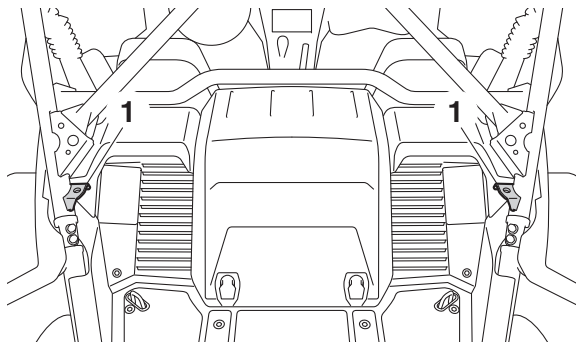

1. Flag pole bracket

ECB03010

NOTICE

Do not use the flag pole bracket as a cargo hook.

EBU40060

Front shock absorbers

The shock absorber assemblies are equipped with the following adjusters.

- Spring preload adjusting nut
- Rebound damping force adjusting screw
- High speed compression damping force adjusting bolt
- Low speed compression damping force adjusting screw
- Crossover adjusting nut

EWB04140

! WARNING

- **Suspension components become hot during operation. Never touch the compression damping force adjusting bolt and screw, the rebound damping force adjusting bolt and screw, or the oil reservoir with your bare hand or skin until suspension components have cooled.**
- **Always adjust the shock absorber assemblies on the left and right side to the same setting. Uneven adjustment can cause poor handling and loss of stability, which could lead to an accident.**

Notes on adjusting the suspension

- A special wrench and special tool can be obtained at a Yamaha dealer to make the spring preload or crossover setting adjustment.
- When adjusting the damping force settings, turn the adjuster in direction (a) until it stops, and then count the turns or clicks in direction (b).
- Although a damping force adjuster may turn or click beyond the stated minimum settings, such adjustments are ineffective and may damage the suspension.

ECB00091

NOTICE

Never turn an adjusting mechanism beyond the minimum and maximum settings.

Spring preload

1. Elevate the vehicle and place a suitable stand under the frame.
2. Loosen the locknut.

3. Turn the spring preload adjusting nut in direction (a) to increase the spring preload and thereby harden the suspension, and in direction (b) to decrease the spring preload and thereby soften the suspension.

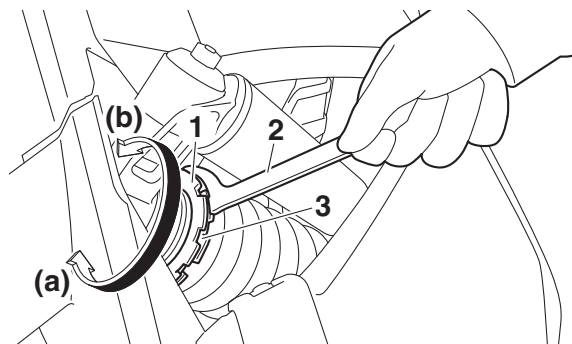

1. Locknut
2. Special wrench
3. Spring preload adjusting nut

TIP

The spring preload setting is determined by measuring distance A, shown in the illustration. The shorter distance A is, the higher the spring preload; the longer distance A is, the lower the spring preload.

5

Spring preload setting:

Minimum (soft):

Distance A =
496.6 mm (19.55 in)

Standard:

Distance A =
483.9 mm (19.05 in)

Maximum (hard):

Distance A =
471.2 mm (18.55 in)

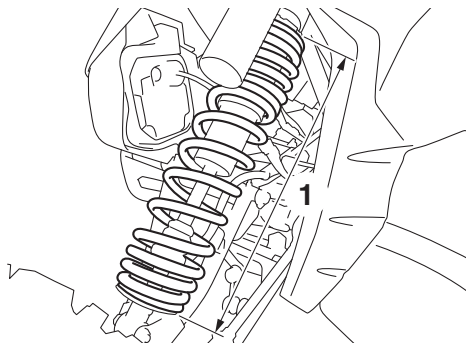

1. Distance A

4. Tighten the locknut to the specified torque. **NOTICE: Always tighten the locknut against the adjusting nut, and then tighten it to the specified torque.**

[ECB00082]

Tightening torque:

Locknut:

41 N·m (4.1 kgf·m, 30 lb·ft)

Crossover setting

The crossover setting adjusts the timing when the shock absorber transitions from the soft spring to the hard spring.

TIP

- It is recommended to adjust the crossover setting a similar distance whenever the spring preload is adjusted.
 - The crossover setting is measured from the bottom of the spring retainer to the top of the crossover locknut.
-

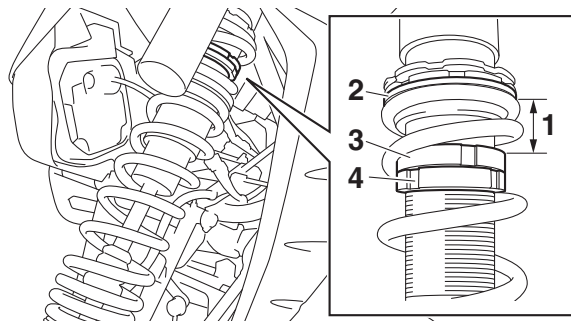

1. Distance B
2. Spring retainer
3. Crossover locknut
4. Crossover adjusting nut

1. Loosen the crossover locknut as shown.

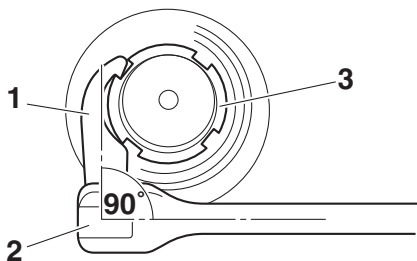

1. Special tool
2. 3/8 inch (9.5 mm) drive wrench
3. Crossover locknut

2. Turn the crossover adjusting nut in direction (a) to increase the crossover setting and in direction (b) to decrease the crossover setting.

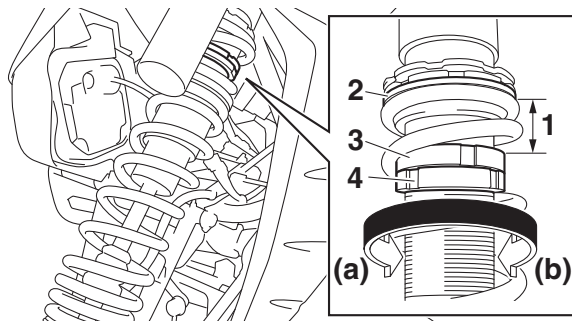

1. Distance B
2. Spring retainer
3. Crossover locknut
4. Crossover adjusting nut

Crossover setting:

Minimum (soft):

Distance B = 19.2 mm (0.76 in)

Standard (recommended):

Distance B = 26.8 mm (1.06 in)

Maximum (hard):

Distance B = 39.5 mm (1.56 in)

3. Tighten the locknut to the specified torque. **NOTICE: Always tighten the locknut against the adjusting nut, and then tighten it to the specified torque.**

[ECB00082]

Tightening torque:

Locknut:

41 N·m (4.1 kgf·m, 30 lb·ft)

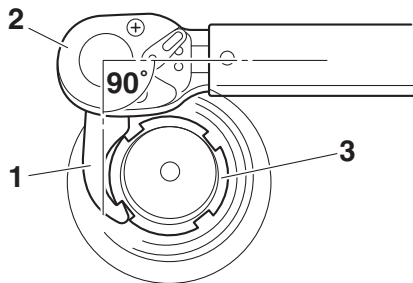

1. Special tool
2. Torque wrench
3. Crossover locknut

Rebound damping force

Turn the rebound damping force adjusting screw in direction (a) to increase the rebound damping force and thereby harden the damping, and in direction (b) to decrease the rebound damping force and thereby soften the damping.

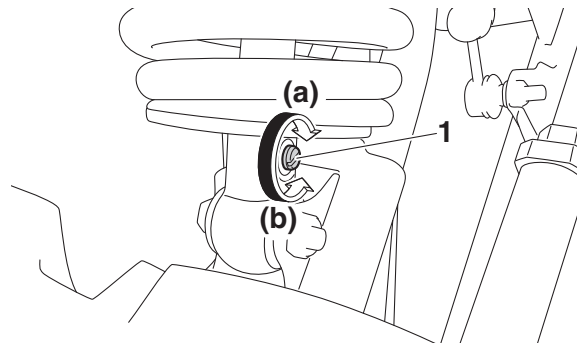

1. Rebound damping force adjusting screw

Rebound damping setting:

Minimum (soft):

26 click(s) in direction (b)

Standard:

12 click(s) in direction (b)

Maximum (hard):

1 click(s) in direction (b)

5

Compression damping force

High speed compression damping force

To increase the compression damping force and thereby harden the high speed compression damping, turn the compression damping force adjusting bolt in direction (a). To decrease the compression damping force and thereby soften the high speed compression damping, turn the adjusting bolt in direction (b).

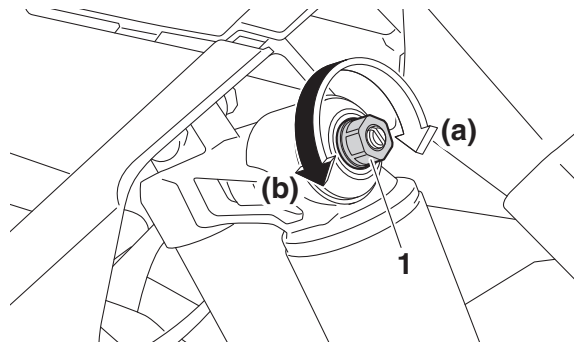

1. High speed compression damping force adjusting bolt

High speed compression damping setting

Minimum (soft):

4 turn(s) out from the fully turned in position

Standard:

2 turn(s) out from the fully turned in position

Maximum (hard):

Adjusting bolt fully turned in

Low speed compression damping force

To increase the compression damping force and thereby harden the low speed compression damping, turn the compression damping force adjusting screw in direction (a). To decrease the compression damping force and thereby soften the low speed compression damping, turn the adjusting screw in direction (b).

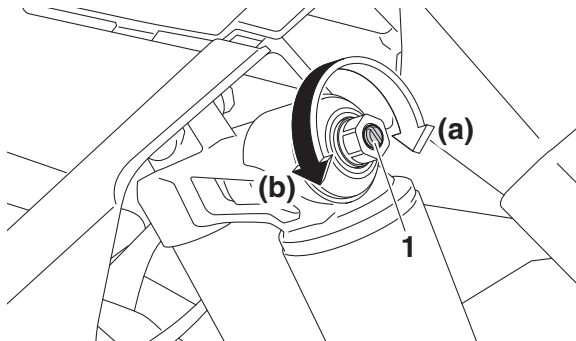

1. Low speed compression damping force adjusting screw

Low speed compression damping setting

Minimum (soft):

4 turn(s) out from the fully turned in position

Standard:

2 turn(s) out from the fully turned in position

Maximum (hard):

Adjusting screw fully turned in

EWB00411



These shock absorber assemblies contain highly pressurized nitrogen gas. Read and understand the following information before handling the shock absorber assemblies.

- **Do not tamper with or attempt to open the cylinder assemblies.**
- **Do not subject the shock absorber assemblies to an open flame or other high heat source. This may cause the unit to explode due to excessive gas pressure.**

- **Do not deform or damage the cylinders in any way. Cylinder damage will result in poor damping performance.**
 - **Do not dispose of a damaged or worn out shock absorber assembly yourself. Take the shock absorber assembly to a Yamaha dealer for any service.**
-

5

EBU40070

Rear shock absorbers

The shock absorber assemblies are equipped with the following adjusters.

- Spring preload adjusting nut
- Rebound damping force adjusting screw
- High speed compression damping force adjusting bolt
- Low speed compression damping force adjusting screw
- Crossover adjusting nut

EWB04140

! WARNING

- **Suspension components become hot during operation. Never touch the compression damping force adjusting bolt and screw, the rebound damping force adjusting bolt and screw, or the oil reservoir with your bare hand or skin until suspension components have cooled.**
 - **Always adjust the shock absorber assemblies on the left and right side to the same setting. Uneven adjustment can cause poor handling and loss of stability, which could lead to an accident.**
-

Notes on adjusting the suspension

- A special wrench and special tool can be obtained at a Yamaha dealer to make the spring preload or crossover setting adjustment.

- When adjusting the damping force settings, turn the adjuster in direction (a) until it stops, and then count the turns or clicks in direction (b).
- Although a damping force adjuster may turn or click beyond the stated minimum settings, such adjustments are ineffective and may damage the suspension.

ECB00091

NOTICE

Never turn an adjusting mechanism beyond the minimum and maximum settings.

Spring preload

1. Elevate the vehicle and place a suitable stand under the frame.
2. Loosen the locknut.
3. Turn the spring preload adjusting nut in direction (a) to increase the spring preload and thereby harden the suspension, and in direction (b) to decrease the spring preload and thereby soften the suspension.

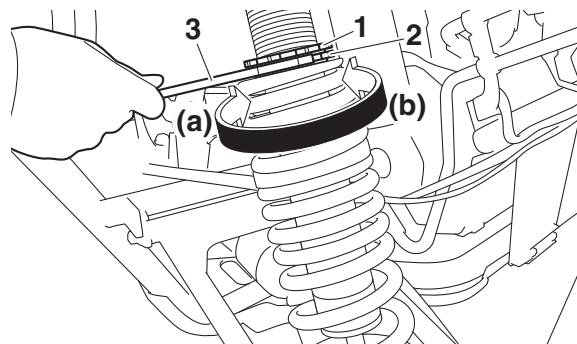

1. Locknut
2. Spring preload adjusting nut
3. Special wrench

TIP

The spring preload setting is determined by measuring distance A, shown in the illustration. The shorter distance A is, the higher the spring preload; the longer distance A is, the lower the spring preload.

Spring preload setting:

Minimum (soft):

Distance A =
610.9 mm (24.05 in)

Standard:

Distance A =
598.2 mm (23.55 in)

Maximum (hard):

Distance A =
585.5 mm (23.05 in)

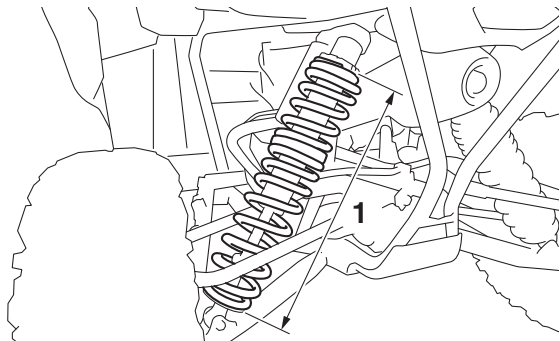

1. Distance A

4. Tighten the locknut to the specified torque. **NOTICE: Always tighten the locknut against the adjusting nut, and then tighten it to the specified torque.**

[ECB00082]

Tightening torque:

Locknut:

41 N·m (4.1 kgf·m, 30 lb·ft)

Crossover setting

The crossover setting adjusts the timing when the shock absorber transitions from the soft spring to the hard spring.

TIP

- It is recommended to adjust the crossover setting a similar distance whenever the spring preload is adjusted.
- The crossover setting is measured from the bottom of the spring retainer to the top of the crossover locknut.

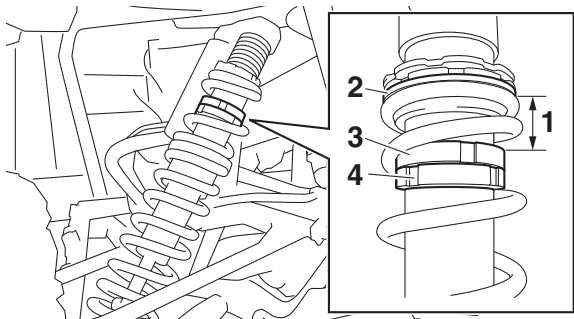

1. Distance B
2. Spring retainer
3. Crossover locknut
4. Crossover adjusting nut

1. Loosen the crossover locknut as shown.

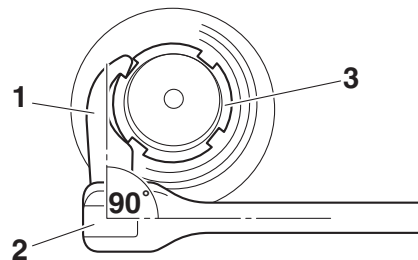

1. Special tool
2. 3/8 inch (9.5 mm) drive wrench
3. Crossover locknut

2. Turn the crossover adjusting nut in direction (a) to increase the crossover setting and in direction (b) to decrease the crossover setting.

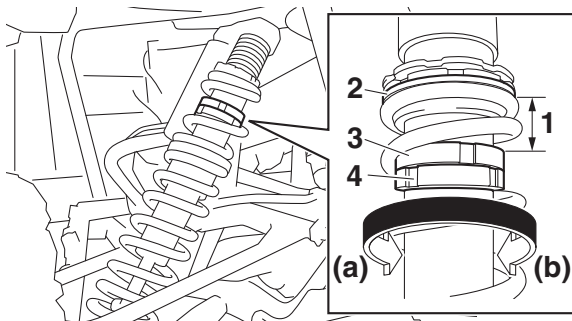

1. Distance B
2. Spring retainer
3. Crossover locknut
4. Crossover adjusting nut

Crossover setting:

Minimum (soft):

Distance B = 48.5 mm (1.91 in)

Standard (recommended):

Distance B = 61.2 mm (2.41 in)

Maximum (hard):

Distance B = 73.9 mm (2.91 in)

3. Tighten the locknut to the specified torque. **NOTICE: Always tighten the locknut against the adjusting nut, and then tighten it to the specified torque.**

[ECB00082]

Tightening torque:

Locknut:

41 N·m (4.1 kgf·m, 30 lb·ft)

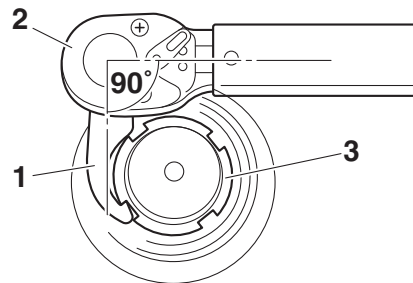

1. Special tool
2. Torque wrench
3. Crossover locknut

Rebound damping force

Turn the rebound damping force adjusting screw in direction (a) to increase the rebound damping force and thereby harden the damping, and in direction (b) to decrease the rebound damping force and thereby soften the damping.

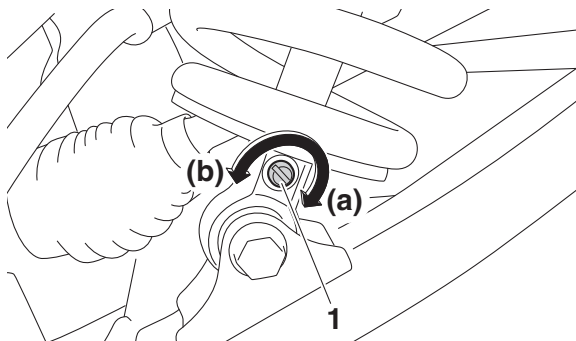

1. Rebound damping force adjusting screw

Rebound damping setting:

Minimum (soft):

26 click(s) in direction (b)

Standard:

12 click(s) in direction (b)

Maximum (hard):

1 click(s) in direction (b)

Compression damping force

High speed compression damping force

To increase the compression damping force and thereby harden the high speed compression damping, turn the compression damping force adjusting bolt in direction (a). To decrease the compression damping force and thereby soften the high speed compression damping, turn the adjusting bolt in direction (b).

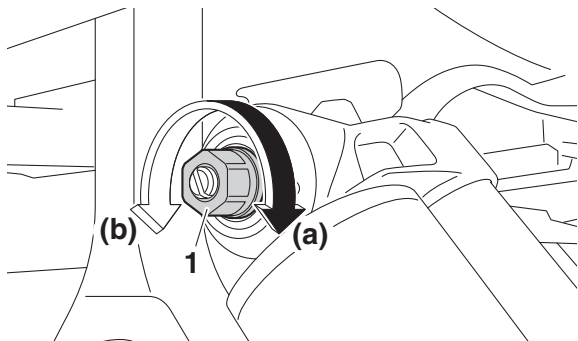

1. High speed compression damping force adjusting bolt

High speed compression damping setting

Minimum (soft):

4 turn(s) out from the fully turned in position

Standard:

2 turn(s) out from the fully turned in position

Maximum (hard):

Adjusting bolt fully turned in

Low speed compression damping force

To increase the compression damping force and thereby harden the low speed compression damping, turn the compression damping force adjusting screw in direction (a). To decrease the compression damping force and thereby soften the low speed compression damping, turn the adjusting screw in direction (b).

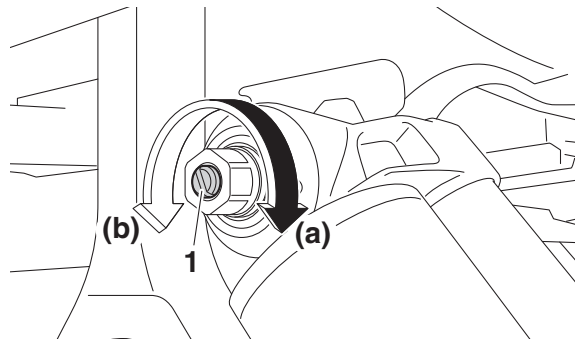

1. Low speed compression damping force adjusting screw

Low speed compression damping setting

Minimum (soft):

4 turn(s) out from the fully turned in position

Standard:

2 turn(s) out from the fully turned in position

Maximum (hard):

Adjusting screw fully turned in

- **Do not deform or damage the cylinders in any way. Cylinder damage will result in poor damping performance.**
- **Do not dispose of a damaged or worn out shock absorber assembly yourself. Take the shock absorber assembly to a Yamaha dealer for any service.**

EWB03500

⚠ WARNING

These shock absorber assemblies contain highly pressurized nitrogen gas. Read and understand the following information before handling the shock absorber assemblies.

- **Do not tamper with or attempt to open the cylinder assemblies.**
- **Do not subject the shock absorber assembly to an open flame or other high heat source. This may cause the unit to explode due to excessive gas pressure.**

EBU35057

Auxiliary DC jack

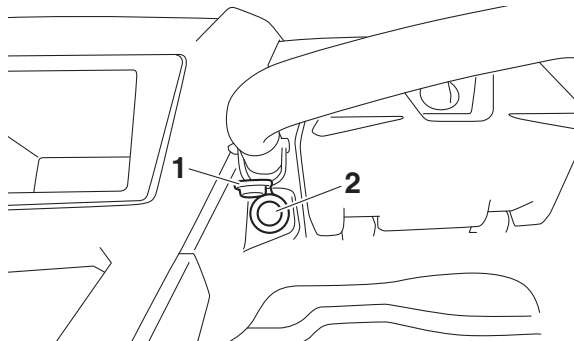

1. Auxiliary DC jack cap
2. Auxiliary DC jack

This model has an auxiliary DC jack located at the left side of the glove compartment. A 12-V accessory with the proper plug, such as a radio or smartphone charger, can be used when the engine is running and the headlights are off.

Auxiliary DC jack maximum capacity:
10.0 A (120 W)

5

1. Start the engine. (See page 7-2.)
2. Turn the headlights off. (See page 5-19.)
3. Open the auxiliary DC jack cap.
4. Make sure the accessory is off.
5. Insert the accessory power plug.
6. Turn the accessory on.

TIP

- Turn off the accessory before plugging in-to/unplugging from the jack.
- When the auxiliary DC jack is not being used, cover it with the cap.

ECB02251

NOTICE

- Do not use accessories requiring more than the stated maximum capacity. Doing so may overload the circuit and cause the fuse to blow.
- If accessories are used while the headlights are on and/or without the engine running, the battery may discharge.
- Do not use an automotive cigarette lighter or other accessories with a plug that gets hot, because the jack can be damaged.

FOR YOUR SAFETY – PRE-OPERATION CHECKS

Before starting off, inspect the vehicle to make sure it is in safe operating condition. Use the following checklist and related information as a guide. Also, follow the service intervals in the periodic maintenance chart to keep the vehicle in safe operating condition.

EWB00482



Failure to inspect or maintain the vehicle properly increases the possibility of an accident or equipment damage. Do not operate the vehicle if you find any problem. If a problem cannot be corrected by the procedures provided in this manual, have the vehicle inspected by a Yamaha dealer.

Pre-operation checklist

ITEM	ROUTINE	PAGE
Brakes	<ul style="list-style-type: none"> • Check operation, free play, fluid level, and fluid leakage. • Fill with DOT 4 brake fluid if necessary. 	6-3, 9-47, 9-53
Parking brake	<ul style="list-style-type: none"> • Check for proper operation, condition, and free play. 	9-52
Fuel	<ul style="list-style-type: none"> • Check fuel level. • Fill with the recommended fuel if necessary. 	6-3
Engine oil	<ul style="list-style-type: none"> • Check oil level. • Fill with oil to proper level if necessary. 	6-5, 9-18

ITEM	ROUTINE	PAGE
Drivetrain	<ul style="list-style-type: none"> • Check front differential, transmission case, and rear final gear for leakage. 	6-6, 6-6, 6-6, 9-29, 9-31, 9-34
Coolant	<ul style="list-style-type: none"> • Check coolant level in reservoir. • Fill with coolant if necessary. 	6-6, 9-36
Accelerator pedal	<ul style="list-style-type: none"> • Check free play and for proper operation. 	6-6
Seat belts	<ul style="list-style-type: none"> • Check for proper operation and belt wear. 	6-7
Passenger handhold	<ul style="list-style-type: none"> • Check for stability and proper fastening. 	6-7, 8-8
Steering	<ul style="list-style-type: none"> • Check for proper operation. 	6-7
Drive select lever and shift paddles	<ul style="list-style-type: none"> • Check for proper operation. 	6-7
YCC-S clutch	<ul style="list-style-type: none"> • Check operation. • Check fluid level in reservoir. • If necessary, add specified brake fluid to specified level. • Check hydraulic system for leakage. 	6-8
Fittings and fasteners	<ul style="list-style-type: none"> • Check all fittings and fasteners. 	6-8
Instruments, lights and switches	<ul style="list-style-type: none"> • Check for proper operation. 	4-3, 5-2, 6-8, 9-66, 9-67
Wheels and tires	<ul style="list-style-type: none"> • Check tire pressure and for wear and damage. 	6-8, 9-57, 9-59
Axle boots	<ul style="list-style-type: none"> • Check for damage. 	9-38

Front and rear brakes

Brake pedal

- Check that there is no free play in the brake pedal. If there is free play, have a Yamaha dealer check the brake system. (See page 9-51.)
- Check the operation of the brake pedal. It should move smoothly and there should be a firm feeling when the brakes are applied. If not, have the vehicle inspected by a Yamaha dealer.

Brake fluid level

Check the brake fluid level. Add fluid if necessary. (See page 9-48.)

Specified brake fluid: DOT 4

Brake fluid leakage

Check to see if any brake fluid is leaking out of the pipe joints or the brake fluid reservoir. Apply the brakes firmly for one minute. If there is any leakage, have the vehicle inspected by a Yamaha dealer.

Brake operation

Check the operation of the brakes at the start of every drive. Test the brakes at slow speed after starting out to make sure they are working properly. If the brakes do not provide proper braking performance, inspect the brake system. (See page 9-47.)

EBU36972

Fuel

Make sure there is sufficient fuel in the tank. Refuel if necessary.

⚠ WARNING

Gasoline and gasoline vapors are extremely flammable. To avoid fires and explosions and to reduce the risk of injury when refueling, follow these instructions.

1. Before refueling, turn off the engine and be sure that no one is sitting in the vehicle.
Never refuel while smoking, or while in the vicinity of sparks, open flames, or other sources of ignition such as the pilot lights of water heaters and clothes dryers.
2. Do not overfill the fuel tank. Because fuel expands when it heats up, heat from the engine or the sun can cause fuel to spill out of the fuel tank.
3. Wipe up any spilled fuel immediately.
4. Be sure the fuel tank cap is closed securely.

6

⚠ WARNING

Gasoline is poisonous and can cause injury or death. Handle gasoline with care. Never siphon gasoline by mouth. If you should swallow some gasoline or inhale a lot of gasoline vapor, or get some gasoline in your eyes, see your doctor immediately. If gasoline spills on your skin, wash with soap and water. If gasoline spills on your clothing, change your clothes.

Recommended fuel:

Regular unleaded gasoline (Gasohol [E10] acceptable)

Fuel tank capacity:

34 L (9.0 US gal, 7.5 Imp.gal)

Fuel reserve amount:

8.5 L (2.24 US gal, 1.87 Imp.gal)

If knocking or pinging occurs, try a different brand or higher octane gasoline. Unleaded fuel will give you longer spark plug life and reduced maintenance cost. Gasoline contain-

ing ethanol can be used if the ethanol content does not exceed 10% (E10). Gasoline containing methanol is not recommended because it can cause damage to the fuel system or vehicle performance problems.



TIP

- This mark identifies the recommended fuel for this vehicle as specified by European regulation (EN228).
 - Check that gasoline nozzle has the same identifier when fueling.
-

Portable fuel containers

If you carry a portable fuel container in the bed of your Yamaha YXZ1000ET, be sure to secure it with the cap tightened before driving the vehicle.

Always place a portable fuel container on the ground before filling it. Before removing the container cap, touch the container with the fuel dispenser nozzle. Keep fuel dispenser nozzle in contact with container inlet when filling. **WARNING! Never refill a fuel container in the bed of any vehicle. Fire may result from a build-up of static electricity. The discharge of this build-up while refueling can cause a spark and ignite the gasoline.**

[EWB03270]

EBU35680

Engine oil

Make sure the engine oil is at the specified level. Add oil as necessary. (See page 9-18.)

NOTICE

- **Do not use oils with a diesel specification of “CD” or oils of a higher quality than specified. In addition, do not use oils labeled “ENERGY CONSERVING II” or higher.**
- **Make sure that no foreign material enters the oil tank.**

6

Recommended engine oil type and quantity:
See page 11-1.

Transmission

Make sure there is no oil leaking from the transmission case.

Coolant

Check the coolant level in the reservoir and replenish if necessary. (See page 9-36.)

Final gear

Make sure there is no oil leaking from the final gear case.

Differential gear

Make sure there is no oil leaking from the differential gear case.

Accelerator pedal

Before starting the engine, confirm that the accelerator pedal operates correctly. It should depress smoothly and spring back to the idle position when released. Also check the accelerator pedal for excessive free play. If the accelerator pedal is not in correct working order, have the vehicle inspected before starting off.

EBU31800

Seat belts

Make sure that the seat belts are not frayed, torn, stretched, or damaged. The seat belts must move smoothly when pulled out and retract on its own when released. The seat belts must also lock up when quickly pulled out. The latch plate should click securely into the buckle and release when the release button is pushed firmly. Wash off any dirt or mud that could affect operation. Have a Yamaha dealer repair as necessary for proper operation.

A crash can damage the restraint systems in your vehicle. A damaged restraint system may not properly protect the person using it, resulting in serious injury or death in a crash. To help make sure your restraint systems are working properly after a crash, have them inspected and any necessary replacements made as soon as possible.

EBU31810

Passenger handhold

Check that the handhold bar and its supports are in good condition. Confirm that the locking pins are securely fastened, and then push and pull on the handhold to make sure that it is not loose.

EBU31820

Steering

Park on level ground. Turn the steering wheel right and left. Check for excessive free play, abnormal noises, or a rough feeling. Have a Yamaha dealer repair as necessary for proper operation.

EBU36691

Drive select lever and shift paddles

The drive select lever and shift paddles should move smoothly and return to their original position.

EBU36672

YCC-S clutch

Check the YCC-S clutch fluid level and correct if necessary. (See page 9-48.)

Check the operation of the drive select lever and shift paddles at the start of each drive.

TIP _____

- If the YCC-S clutch fluid level was low, be sure to check the clutch system for leakage.
- If any leakage is found, or if shifting is not smooth, have a Yamaha dealer service the vehicle.

EBU35700

Fittings and fasteners

Always check the tightness of chassis and wheel fittings and fasteners before starting off. Take the vehicle to a Yamaha dealer or refer to the Service Manual for correct tightening torque.

EBU31840

Instruments, lights and switches

Check that all instruments, lights and switches are working properly. Correct if necessary.

EBU31851

Control cables

When driving in cold weather, always make sure all control cables work smoothly before starting off. **WARNING! Control cables can freeze in cold weather and you could be unable to control the vehicle.** [EWB03280]

EBU37895

Tires

Check and adjust the tire pressure before each ride. Check tires for wear and damage.

Tire pressure

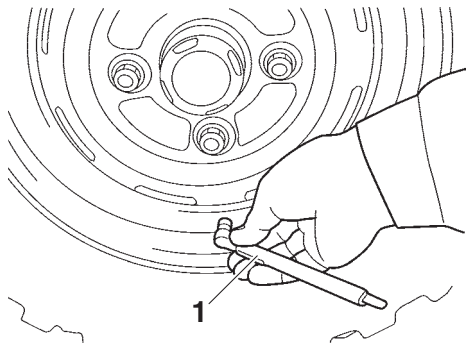

1. Tire pressure gauge

A tire pressure gauge is included as standard equipment. Make two measurements of the tire pressure and use the second reading. Dust or dirt in the gauge could cause the first reading to be incorrect.

Tire pressure must be checked and set when the tires are cold. The tire pressure should be the same on both sides, and must be adjusted according to vehicle loading conditions. Set the tire pressure as specified below.

WARNING! Operation of this vehicle with

improper tire pressure may cause severe injury or death from loss of control or roll-over. Tire pressure below the minimum specified could also cause the tire to dislodge from the rim under severe driving conditions. [EWB04120]

OPERATING TIRE PRESSURE (cold):**VEHICLE LOAD of 0.0–195.0 kg (0–430 lb)**

FRONT: (Recommended)

114.0 kPa (1.140 kgf/cm², 16.5 psi)

REAR: (Recommended)

128.0 kPa (1.280 kgf/cm², 18.5 psi)

Front: (Minimum)

110.0 kPa (1.100 kgf/cm², 16.0 psi)

Rear: (Minimum)

124.0 kPa (1.240 kgf/cm², 18.0 psi)**VEHICLE LOAD of 195.0–328.0 kg (430–723 lb)**

FRONT: (Recommended)

114.0 kPa (1.140 kgf/cm², 16.5 psi)

REAR: (Recommended)

169.0 kPa (1.690 kgf/cm², 24.5 psi)

Front: (Minimum)

110.0 kPa (1.100 kgf/cm², 16.0 psi)

Rear: (Minimum)

165.0 kPa (1.650 kgf/cm², 24.0 psi)

Vehicle load is total weight of operator, passenger, accessories, and cargo. Do not exceed maximum vehicle load of 328.0 kg (723 lb).

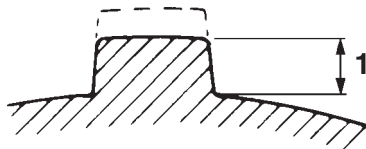
Tire inspection

1. Tire tread depth

When the tire tread depth has worn to 3 mm (0.12 in) replace the tire. If the tire has a nail or glass fragments in it, or if the sidewall is cracked, replace the tire.

OPERATION

Read the Owner's Manual carefully to become familiar with all controls. If there is a control or function you do not understand, ask your Yamaha dealer.



Failure to familiarize yourself with the controls can lead to loss of control, which could cause an accident or injury.

Engine break-in

There is never a more important period in the life of your vehicle than the period between 0 and 20 hours.

For this reason, we ask that you read the following material carefully. Because the engine is brand new, you must not put an excessive load on it for the first several hours of operation. During the first 20 hours, the various

parts in the engine wear and polish themselves to achieve the correct operating clearances.

During this period, prolonged full-throttle operation or any condition that might result in excessive engine heating must be avoided. However, momentary (2–3 seconds maximum) full-throttle operation under load does not harm the engine.

Each full-throttle acceleration sequence should be followed with a substantial rest period for the engine, by cruising at lower r/min so the engine can rid itself of the temporary build-up of heat. If any abnormality is noticed during this period, consult a Yamaha dealer.

0–10 hours:

Avoid prolonged operation above 5300 r/min. Allow a cooling-off period of 5 to 10 minutes after every hour of operation. Vary the speed of the vehicle from time to time. Do not operate it at one set throttle position.

10–20 hours:

Avoid prolonged operation above 6300 r/min.

After break-in:

The vehicle may now be operated normally.

EBU36560

Starting the engine

1. Turn the key to “ I ” (on).

ECB03340

NOTICE

The coolant temperature warning light, YCC-S system warning light, and engine trouble warning light should come on, then go off.

The EPS warning light should come on, then go off when the engine is started.

To avoid possible damage, do not operate the vehicle if a warning light does not work as described above.

2. Press the brake pedal.
3. Shift the transmission into neutral.

- When the transmission is in the neutral position, the transmission gear display shows “N” and the neutral indicator light should come on.
 - The engine can be started in any gear if the brake pedal is applied. However, it is recommended to shift into neutral before starting the engine.
4. With your foot off the accelerator pedal, start the engine by turning the key to “  ” (start).

If the engine fails to start, release the key, and then try starting it again. Wait a few seconds before the next attempt. Each attempt should be as short as possible, to preserve battery energy. **NOTICE: Do not crank the engine more than 5 seconds on each attempt, or starter damage could occur. Wait at least 5 seconds between each operation of the electric starter to let it cool.** [ECB02140]

Do not turn the key to the “  ” (start) position with the engine running; otherwise, damage to the electric starter may result.

TIP _____
For maximum engine life, never accelerate hard when the engine is cold!

EBU36723

Shifting and reverse driving

This vehicle is equipped with a 5-speed forward and 1-speed reverse manual transmission with YCC-S (see page 5-23). The transmission allows you to control the amount of power you have available at a given speed for starting off, accelerating, climbing hills, engine braking, etc.

Shift gears using the drive select lever and the shift paddles; clutch operation is automatic. Use the drive select lever to shift the transmission into forward drive (first gear), neutral, and reverse gear as shown. Use the shift paddles to shift through the forward gears as shown.

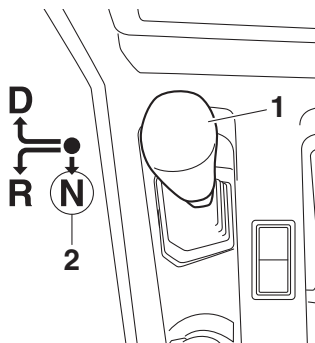

1. Drive select lever
2. Neutral position

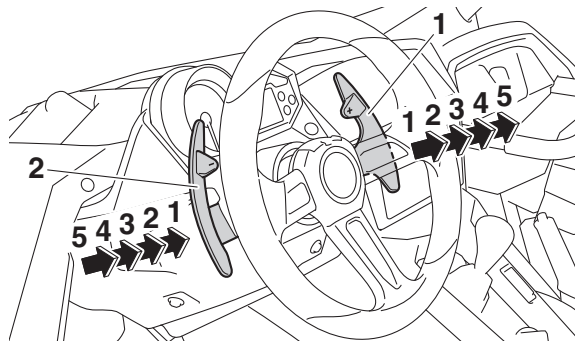

1. Shift paddle “+”
2. Shift paddle “-”

NOTICE

Even with the transmission in the neutral position, do not coast for long periods of time with the engine off. The transmission is properly lubricated only when the engine is running. Inadequate lubrication may damage the transmission.

To start out and accelerate

1. Take your foot off the accelerator pedal and apply the brake pedal. **NOTICE: Always take your foot off the accelerator pedal before operating the drive select lever, otherwise damage to the engine and drivetrain may result.** [ECB03360]
2. Release the parking brake (if applied).
3. Shift into first gear using the drive select lever (the transmission gear display should show “1”).
4. Release the brake pedal and press the accelerator pedal gradually.

TIP

- To use the drive select lever, you must be pressing the brake pedal and be stopped (be traveling less than 5 km/h [3 mph]), and the engine should be at idle speed.
- You can shift between forward (first gear) and reverse gear directly - it is not necessary to shift into neutral.
- When using the shift paddles, YCC-S may not complete the upshift if engine or vehicle speed is too low, nor complete the downshift if engine or vehicle speed is too high.
- When AUTO DOWNSHIFT is downshifting gears, do not operate the shift paddles or accelerator pedal.
- During an emergency stop or sudden braking, AUTO DOWNSHIFT will not downshift the transmission to first gear. Use the shift paddle “-” to downshift, and then apply the accelerator pedal to resume normal operation.

5. When vehicle speed has sufficiently increased, use the shift paddle “+” to shift into second gear (“2”).
6. Follow the same procedure when shifting to the next higher gear.

To decelerate

When slowing down, release the accelerator pedal and apply the brake pedal smoothly. As you slow down, shift to a lower gear. Be sure that the engine has sufficiently slowed before engaging a lower gear. Improper use of the brake pedal or shift paddles can cause the tires to lose traction, reducing control and increasing the possibility of an accident.

EWB00712



Make sure the engine has sufficiently slowed before shifting to a lower gear. Engaging a lower gear when the engine speed is too high could make the wheels stop rotating and lose traction. This could

cause loss of control, an accident and injury. It could also cause engine or drivetrain damage.

Recommended shift points

The recommended shift points during acceleration and deceleration are shown in the following table.

Shift up points:

1st → 2nd: 19 km/h (12 mi/h)

2nd → 3rd: 33 km/h (21 mi/h)

3rd → 4th: 44 km/h (27 mi/h)

4th → 5th: 53 km/h (33 mi/h)

Shift down points:

5th → 4th: 30 km/h (19 mi/h)

4th → 3rd: 17 km/h (11 mi/h)

TIP

When coming to a stop under normal conditions, AUTO DOWNSHIFT will shift the transmission into first gear automatically.

To drive in reverse

EWB03300

⚠ WARNING

Before you shift into reverse, make sure there are no obstacles or people behind you. When it is safe to proceed, go slowly. Hitting an obstacle or person could result in serious injury or death.

1. Stop the vehicle and continue to apply the brake pedal.
2. Check behind you.
3. Shift the transmission into reverse.

7

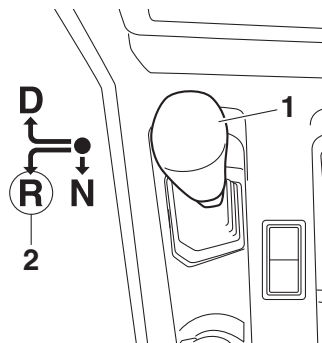

1. Drive select lever
2. Reverse gear

TIP

- To shift into reverse, the engine must be running and at idle speed.
- When in reverse, the transmission gear display should show “R” and the reverse indicator light should come on.
- The reverse buzzer will sound while the transmission is in reverse.

4. Release the parking brake (if applied).

5. Check behind you, then release the brake pedal and press the accelerator pedal gradually.
6. Continue to watch to the rear while driving in reverse.

EBU37790

Dynamic clutch engagement

When driving up a steep hill or over rocky terrain at very slow speed in 1st gear, or when stuck in a rut and extra “oomph” is needed to climb up and over the obstacle, use this feature as follows.

1. With the transmission in 1st gear, fully depress the accelerator pedal.
2. After a few moments, YCC-S will fully engage the clutch thereby transmitting full power to the drive wheels.
3. Release the accelerator pedal as needed and resume normal driving.

TIP

- Correct accelerator pedal free play is necessary for proper operation.

- Dynamic clutch engagement works in 1st gear only.
- Time to engagement will vary depending on conditions.

ECB03740

NOTICE

Do not use repeatedly in a short period of time. Otherwise, the clutch system may be damaged.

EBU36734

Launch system operation

The launch system allows you to start off at a higher engine speed, and thus have a higher initial acceleration rate than normal operation. Only use the launch system on level ground with a clear and safe path ahead of you.

TIP

The launch system will be prevented from operating if any of the following conditions are present:

- the engine is not warmed up or is overheating.
 - the driver seat belt is not latched.
 - the differential gear is locked (“DIFF. LOCK” is selected) or the differential gear lock indicator is flashing.
 - the parking brake is applied.
 - an engine or system malfunction is detected (a warning light is on).
-

To activate the launch system

7

1. Confirm that the front wheels and steering wheel are pointed straight ahead.
2. Shift the transmission into first gear.
3. While pressing the brake pedal, pull both shift paddles toward you and hold them in that position. The launch system indicator light will come on, and the launch system enters standby mode.

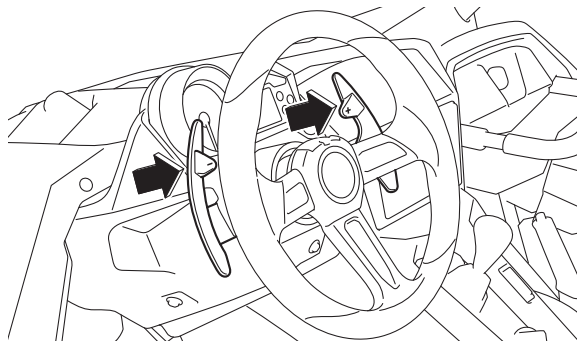

4. While checking in front of you for obstacles or anything that may cross your path, release the brake pedal, and then press the accelerator pedal to rev the engine to the desired launch engine speed.

TIP

- The engine speed at launch must be between 5000–10000 r/min.
- If you release one shift paddle, or if a system restriction is detected during standby mode, the launch system indicator light will begin to flash and the launch will be cancelled.

- If the indicator light is flashing, release the accelerator pedal and let the engine return to idle speed. When the indicator light goes off, you may start off normally or retry activating the launch system.
-

5. When ready, release both shift paddles at the same time and further press the accelerator pedal to launch the vehicle.

TIP

When the clutch has completely engaged, the launch system and the launch system indicator light will turn off.







ECB03430

NOTICE

Do not make consecutive launches without allowing the clutch to cool down. Otherwise, the clutch system may be damaged.

Selecting the drive mode

The vehicle handles differently in each of the drive modes: “2WD”, “4WD” and “DIFF. LOCK”. For example, the vehicle requires more effort to turn in “DIFF. LOCK” than in “2WD”. Always stop the vehicle before changing the position of the On-Command drive knob. The drive mode icon changes according to the selected drive mode. The drive mode icon and the “DIFF. LOCK” indicator light come on as follows:

Knob position	Indication	Drive mode
	(none) 	“2WD” (two-wheel drive): Drive power is supplied to the rear wheels only.
		“4WD” (four-wheel drive): Drive power is supplied to the front and rear wheels.
		“DIFF. LOCK” (four-wheel drive with the differential gear locked): Drive power is supplied to the front and rear wheels and the differential gear is locked. Unlike in four-wheel drive, all wheels turn at the same speed.

TIP

- When the knob is set to “DIFF. LOCK” or “4WD”, the drive mode icon and the indicator light will flash until the differential gear is completely locked or unlocked.
 - Turning the steering wheel back and forth will help the differential gear lock to engage or disengage.
 - To protect the drivetrain from damage, vehicle speed is limited until the differential gear lock has properly transitioned.
 - To protect the drivetrain from damage, maximum vehicle speed is limited to approximately 65 km/h (40 mi/h) when in “DIFF. LOCK” mode.
-

Parking

When parking, shift into first or reverse gear, stop the engine, and then apply the parking brake. See page 8-16 for when parking on a slope.

Loading

Take extra precautions when driving with a load. Turn gradually and drive more slowly than you would without a load. The more weight you carry, the slower you should go. Although conditions vary, it is good practice to keep the vehicle in a low gear when you are carrying a heavy load. Follow these instructions and always use common sense and good judgment when carrying a load.

Cargo bed

Use the hooks equipped on the cargo bed (page 5-32) to tie down loads. Make sure the load is securely fastened down, centered in the cargo bed, and not top-heavy. Never allow anyone to ride in the cargo bed.



Improper loading or any pulling or towing will increase the risk of loss of control, an overturn, or other accident:

- **Do not pull objects, other vehicles, or tow a trailer—this vehicle is not designed for such operation.**
- **Keep weight in the cargo bed centered side to side, and as low and as far forward as possible. Top-heavy loads increase the risk of overturn.**
- **Make sure that cargo is securely fastened down—a loose load could change handling unexpectedly or strike occupants.**

- Do not exceed the maximum loading limit for the cargo bed: 136.0 kg (300 lb).
 - Do not exceed the maximum loading limit for the vehicle: 328.0 kg (723 lb).
-



BASIC GUIDE FOR SAFE USE

As a YXZ1000ET owner you are responsible for the safe and proper operation of this vehicle. Read this chapter and review the safety instructions in Chapter 3 before operating the vehicle. Use these chapters and the labels on the vehicle to instruct new operators and passengers. Do not allow anyone else to operate the vehicle or ride as a passenger if you are unsure that he/she is willing and able to follow these instructions.

8



Follow these instructions to reduce your risk of an accident and to reduce the risk of serious injury or death in the event of an accident.

KNOW YOUR VEHICLE

This off-road vehicle will handle and maneuver differently from cars, ATVs, go-carts, golf-cars and grounds-keeping vehicles. The YXZ1000ET has higher ground clearance and other features to handle rugged terrain, and, as a result, can overturn in situations where some vehicles may not. This would include vehicles made primarily for pavement, roads, improved paths, or grounds-keeping. If you do not use care in maneuvering the YXZ1000ET, you can cause it to roll over even on flat, open areas.

Doing things with a YXZ1000ET that some people do for thrills in other vehicles [such as sideways sliding, skidding, fishtailing (rear-wheel sliding), or donuts] have led to side roll-overs. These rollovers can result in crushed limbs and other serious injuries or death to drivers or passengers.

As the owner/operator, it is your responsibility to protect yourself and your passenger from accidents, including rollovers. The YXZ1000ET has many features, including a protective structure and seat belts, to help protect occupants, but the best way to avoid injuries is to avoid accidents. There is a risk of injury or death in any accident, even with these safety features.

Driver requirements

- This vehicle is intended for use only by an operator 16 or older with a valid motor vehicle license. Check country laws for minimum age requirements.



- The driver must be able to place both feet flat on the floorboard while seated upright with his/her back against the backrest.
- Do not drive after using drugs or alcohol.
- Remove the ignition key when the vehicle is not in use to prevent unauthorized use of the machine.

Parents:

Many countries have implemented new motor vehicle licensing requirements for young drivers. These requirements are in response to the disproportionately high rate of crashes involving youthful drivers. As with automo-

biles, to promote safe driving behaviors, you should supervise younger drivers and consider setting rules and putting limits on how, when, and where the YXZ1000ET can be used.

Passenger requirements

This vehicle is designed for the operator and one passenger. Allowing passengers to ride improperly can lead to serious injury or death. As the operator, you are responsible for your passenger.

- Your passenger must be able to place both feet on the floorboard while seated upright with his/her back against the backrest.
- Your passenger must be able to reach and hold the passenger handhold.
- Allow only one passenger in the vehicle and only in the designated passenger seat. Do not carry any other passengers. Do not carry passengers in the cargo bed.
- Do not allow someone to ride as a passenger who has been using drugs or alcohol.

- Do not allow children who need child safety seats or booster seats in the YXZ1000ET. The seat belt is not designed to restrain automotive child safety seats.

Occupant protection system

EWB03350



Do not make changes to the occupant protection system. If you install aftermarket products or have your vehicle modified, you may put yourself and others at greater risk of serious injury or death. You are responsible for any such changes to the vehicle.

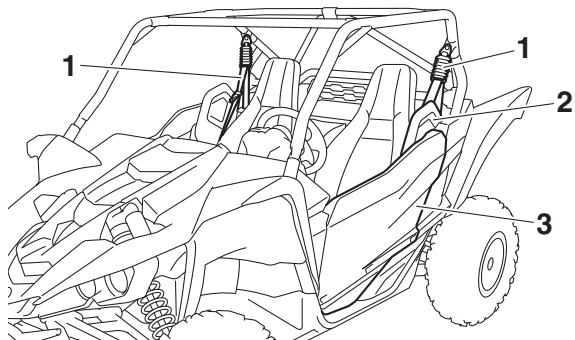

1. Seat belt
2. Shoulder bolster
3. Door

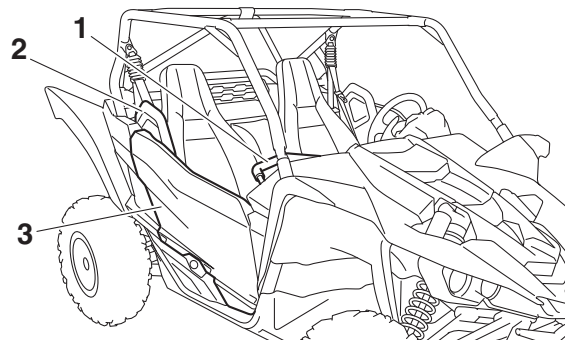

1. Passenger handhold
2. Shoulder bolster
3. Door

The YXZ1000ET comes with a variety of features to help reduce the risk of driver and passenger injury. These features work together, and when properly used, these features will help protect the occupants in the event of an accident. If these features are not used properly, they can cause injury.

Protective structure

The vehicle cage/frame provides a protective structure that helps limit intrusions by branches or other objects and may reduce your risk of injury in accidents. The protective structure will not protect occupants in all rollovers or accidents.

Body parts outside of vehicle can be struck by passing objects or crushed during vehicle rollover. Do not put your hands or feet outside of the vehicle for any reason. Do not hold onto the door, cage/frame or shoulder bolster. Wear your seat belt and helmet.

8

If you think or feel that the vehicle may tip or roll, do not put your hands or feet outside the vehicle for any reason. You will not be able to stop the vehicle from tipping over using your body. Any part of your body (arms, legs, or head) outside of the vehicle can be crushed by the vehicle cage/frame.

Seat belts

Seat belts should be worn by the driver and passenger. The driver must be sure that the passenger is belted before driving.

- Be sure the seat belt is not twisted, is close-fitting across the hips and chest, and is latched securely.
- Do not wear the seat belt across the abdomen or stomach.
- Do not put the seat belt behind the back.

Failure to use seat belts properly may lead to an increased likelihood and severity of injury. An unbelted occupant may strike the interior of the vehicle, the protective structure, or other objects in an accident or during operation. You may also fall completely out or be partially ejected from the vehicle, which may lead to being crushed between the ground and the vehicle. Wearing the seat belt helps you remain in the vehicle – the doors and passenger handhold are not a substitute for using a seat belt.

A crash can damage the restraint systems in your vehicle. A damaged restraint system may not properly protect the person using it, resulting in serious injury or death in a crash. To help make sure your restraint systems are working properly after a crash, have them inspected and any necessary replacements made as soon as possible.

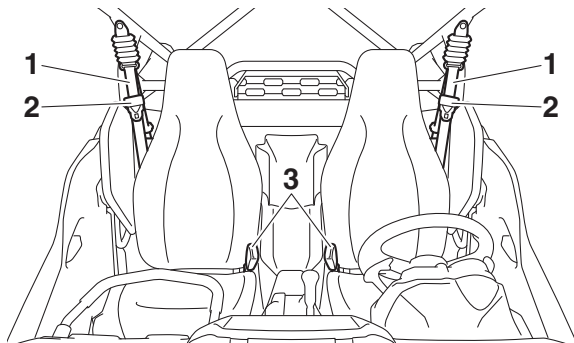

1. Seat belt
2. Latch plate
3. Buckle

To wear the seat belt properly, do the following:

1. Hold the latch plate as you pull the belt across your lap and chest. Make sure the belt is not twisted and is not caught on any portion of the vehicle, your clothing, or any equipment you are carrying.
2. If the latch plate is not positioned in the correct location along the seat belt, adjust its location up or down along the length of the belt.

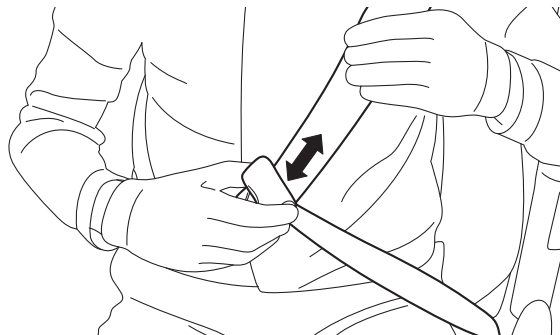

3. Push the latch plate into the buckle until it clicks. Pull up on the latch plate to make sure it is secure.

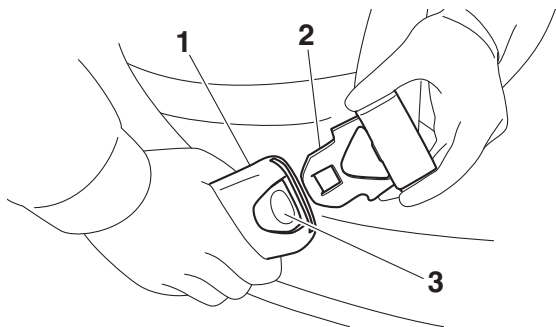

1. Buckle
2. Latch plate
3. Release button

8

4. Put the lap portion of the belt low on your hips. Pull up on the shoulder part so the belt is snug across your hips. Be sure the seat belt is not caught on the shoulder bolster or other object.
5. Position the shoulder belt over your shoulder and across your chest. The shoulder belt should fit against your chest. If it is loose, pull the belt out all the way and then let it retract.

6. Check if the seat belt shoulder position suits the size of the driver and passenger. To lower the belt, insert the belt into the seat belt height adjuster slot as shown. To raise the belt, remove the belt from the height adjuster slot.

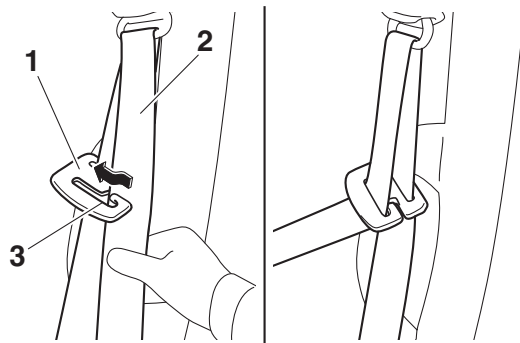

1. Seat belt height adjuster
2. Seat belt
3. Slot

7. To release the buckle, firmly press the release button.

Doors

The doors are designed to reduce the likelihood that you will stick your leg out to stop the vehicle from tipping over or for any other reason in a rollover. The doors may also reduce intrusion of objects into the occupant area. Make sure the door is securely latched before operation. Do not place your arm or hand on the door during operation. Your hand or arm may be struck by objects or crushed against outside objects or the ground during a rollover.

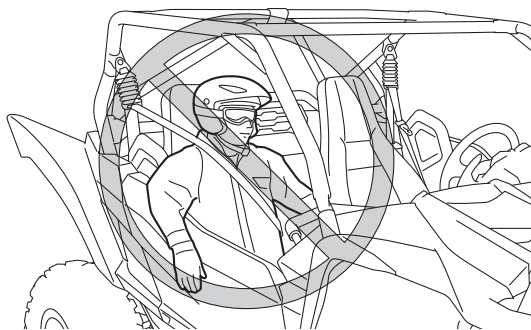

Passenger handhold

The passenger handhold is provided to grip during operation to maintain proper position and balance. Holding onto the handhold helps to reduce the likelihood that the passenger puts a hand outside the vehicle if the vehicle begins to tip.

The driver should make sure the passenger is holding onto the handhold with both hands before operating the vehicle.



Adjusting the handhold position

The handhold can be adjusted to one of three positions to suit the passenger's preference.

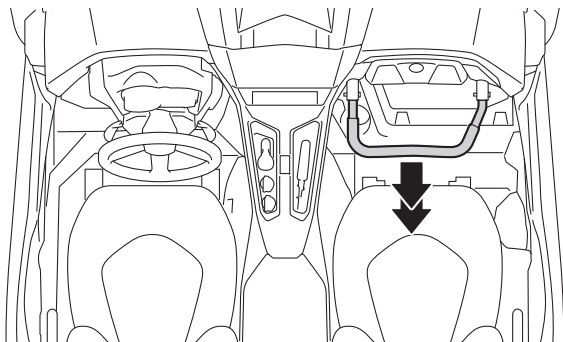

Adjust the handhold position as follows.

1. Remove the locking pins.

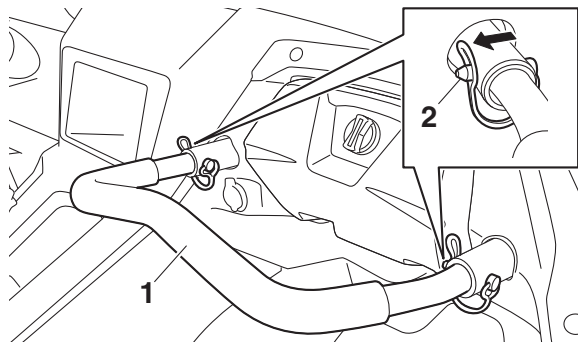

1. Passenger handhold
2. Locking pin

2. Slide the handhold to the desired position and align the holes in the handhold bar with the holes in the handhold supports.

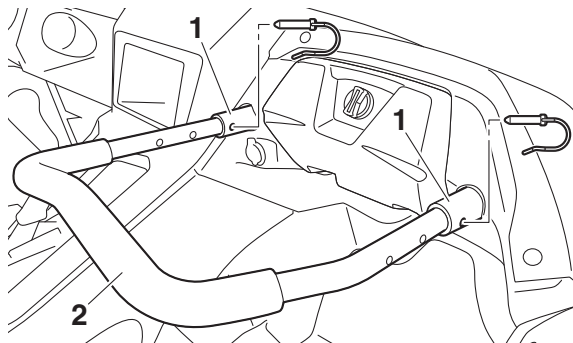

1. Handhold support
2. Handhold bar

3. Insert the pins into the holes and secure them with the wire loops. Make sure that the handhold is properly secured before starting off.

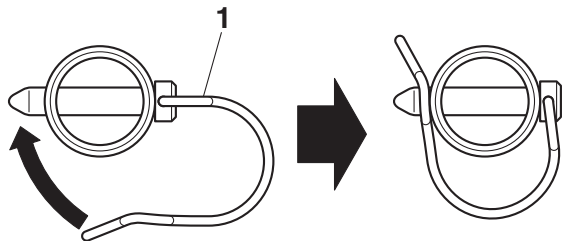

1. Wire loop

Seat and shoulder bolsters

The seats and shoulder bolsters are designed to help keep you in the vehicle. Do not put your hand or arm on or outside of the shoulder bolster during operation. Your hand or arm may be struck by objects or crushed against outside objects or the ground during a rollover.

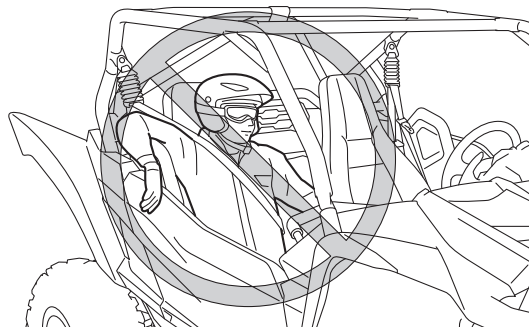

Floorboard

The floorboard allows you to brace your feet, which helps you keep your body in the vehicle in the event of an accident or rollover. Keep your feet on the floorboard during operation.

8

Steering wheel

Keep both hands on the steering wheel. Do not hold the steering wheel with your thumbs inside the rim. Keep your palms on the outside of the steering wheel. Similar to other off-road vehicles, if the YXZ1000ET hits a deep rut or large obstacle, the steering wheel could

briefly jerk in one direction or back and forth as the tires and vehicle respond to the obstacle. This quick motion could injure your thumbs or wrist if your thumbs or hand(s) are inside the steering wheel. Grip the steering wheel so that your thumbs will not be hit by the spokes. As an example, see the illustration.

8

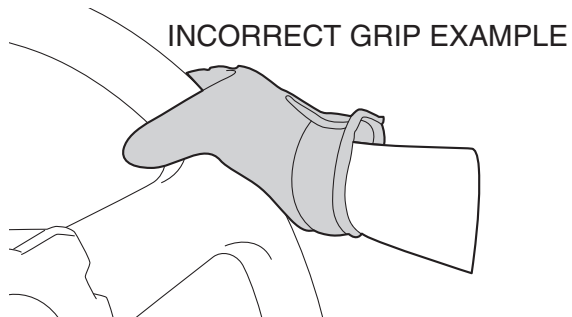
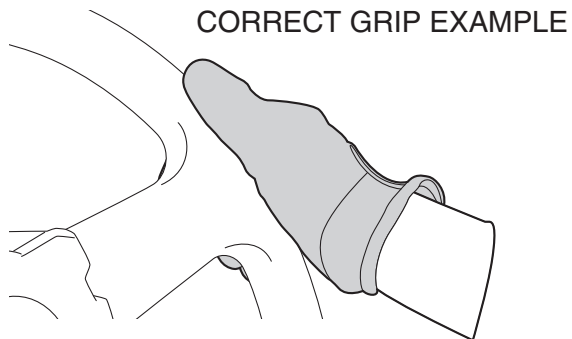

LEARNING TO OPERATE YOUR VEHICLE

Personal protective equipment

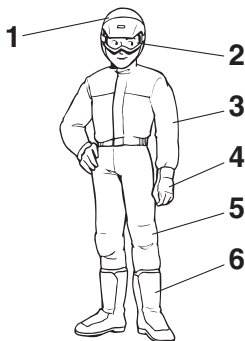

1. Approved motorcycle helmet
2. Eye protection
3. Long-sleeved shirt or jacket
4. Gloves
5. Long pants
6. Over-the-ankle boots

The driver and passenger should wear the following to reduce risk of injury in an accident:

- Approved motorcycle helmet that fits properly

- Eye protection (goggles, helmet face shield, or protective eyewear)
- Over-the-ankle boots, gloves, long-sleeved shirt or jacket, and long pants

An approved helmet and other personal protective equipment can help in a variety of ways, including:

- Reduce the severity of injuries if any part of you is outside the vehicle or protective structure during a rollover.
- Help protect you if outside objects intrude inside the vehicle during operation.
- Help protect you in the event of impact with an obstacle or other vehicle.

Wear eye protection when operating or riding in the vehicle to reduce the risk of a serious accident or injury. Eye protection, such as a face shield or goggles, may reduce the risk of foreign material getting in your eyes and help prevent loss of vision.

Practice for new Yamaha YXZ1000ET users

Become familiar with the performance characteristics of the vehicle in a large, flat area that is free of obstacles and other vehicles. Practice controlling the accelerator pedal, brakes, steering, and shift paddles. Drive at slow speeds with gradual acceleration and smooth turns. Practice applying the accelerator pedal smoothly. Practice slowing down before turning. Practice maintaining a steady amount of throttle (accelerator pedal position) through the turn. Avoid higher speeds until you are thoroughly familiar with the operation and handling of the vehicle. Remember, driving aggressively or making abrupt maneuvers even on flat, open areas can cause side roll-overs.

8

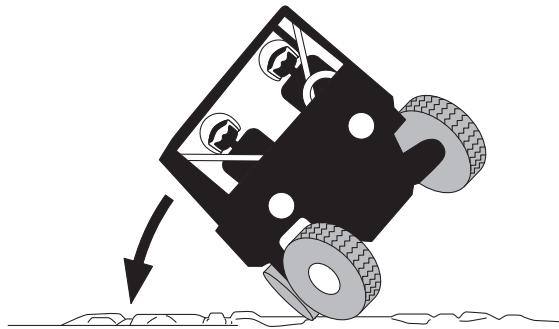

Become familiar with the way the vehicle handles in the various drive modes. Start off with two-wheel drive “2WD”, then four-wheel drive “4WD”, and finally four-wheel drive with the differential locked “DIFF. LOCK”. Steering may take more effort in four-wheel drive with the differential locked “DIFF. LOCK”. Also practice driving in reverse.

TIP

Take the time to learn basic operation of the vehicle before driving at higher speeds or attempting more difficult maneuvers.

Getting ready to ride

Perform the pre-operation checks on page 6-1. Follow the instructions on page 7-2 when starting the engine.

Turning

Use care in turns — turning the steering wheel too far or too fast can result in loss of control or a rollover. Slow down before entering turns. When making tight turns from a standstill or at slow speeds, avoid sudden or hard acceleration. Driving aggressively or making abrupt maneuvers even on flat, open areas can cause side rollovers. Avoid sideways sliding, skidding, or fishtailing (rear-wheel sliding), and never do donuts. If you feel the vehicle begin to slide sideways or the rear wheels begin to slide during a turn, steer into the direction of the slide, if possible, and gradually let off the accelerator pedal to regain directional control and avoid rollover. For example, if you feel the back of the vehicle start to slide to your right, steer to the right.

If you think or feel that the vehicle may tip or roll, keep your body completely inside the protective structure of the vehicle:

- Brace yourself by pressing your feet firmly on the floorboard and keep a firm grip on the steering wheel or passenger handhold.
- Do not put your hands or feet outside of the vehicle for any reason. Do not try to stop a tipover using your arm or leg.

Accelerating

Avoid higher speeds and sudden or hard acceleration until you are thoroughly familiar with the operation of your vehicle. Avoid sudden or hard acceleration in any turn. Never drive faster than is safe for current conditions.

Shifting

Follow the instructions on pages 7-2 and 7-3 for shifting, downshifting, and shifting into reverse until you are thoroughly familiar with each operation.

Braking

When slowing down or stopping, take your foot off the accelerator pedal and press the brake pedal smoothly. Abrupt or improper use of the brakes can cause the tires to lose traction, reducing control of the vehicle and increasing the possibility of an accident.

Braking ability is affected by type of terrain. In most cases, gradual application of the brakes is more effective than abrupt braking, particularly on loose surfaces, such as gravel. Always allow for greater braking distance on rough, loose, or slippery surfaces.

8

Engine compression braking will also help slow the vehicle down. With the transmission still in gear, take your foot off the accelerator and allow the drivetrain and engine to absorb vehicle speed. Downshift as necessary. Application of the brakes provides additional stopping power.

Leaving the vehicle

Do not get out of the vehicle while the engine is running. Take the key with you when you leave the vehicle. There is a serious risk of injury or death because:

- Children or other unauthorized persons may attempt to operate the vehicle.
- Objects tossed into the vehicle may strike the shift lever and accidentally engage the transmission.
- The parking brake may not keep the vehicle from moving.

Parking on a flat area

Even when parking on a seemingly flat area, it is good practice to leave the transmission in gear to prevent the vehicle from rolling. Therefore, shift into first or reverse gear, stop the engine and always apply the parking brake.

Parking on a slope

The parking brake is located on the rear drive shaft. When the drivetrain is in “2WD” mode, only the rear wheels will be locked. Therefore, switch the drive mode to “DIFF. LOCK” before stopping the engine to lock all four wheels when parking. In addition to the parking brake, leave the transmission in gear to help prevent the vehicle from rolling.

If you park on a hill that is too steep, the vehicle may roll out of control. Never park on hills that are so steep you cannot walk up them easily. If you must park on an incline, follow these instructions:

1. First, bring the vehicle to a stop and continue to apply the brake pedal.
2. Switch the drive mode to “DIFF. LOCK” and shift into first gear when parking uphill, or reverse gear when parking downhill.

TIP

You may need to turn the steering wheel left and right to help the differential lock into place.

3. Stop the engine (turn the key to “” [off]).
4. With the brake pedal still being applied, set the parking brake.
5. Finally, get out of the vehicle and block the front and rear wheels with rocks or other objects.

Loading

Be aware that vehicle load includes the total combined weight of the operator, passenger, any installed accessories, and any luggage or cargo brought on board or stored in the cargo bed. Make sure that the gross vehicle weight (vehicle load plus weight of the vehicle itself) never exceeds 1065 kg (2348 lb).

Vehicle loading can affect handling as well as the recommended tire pressure. (See pages 7-12, 6-9.)

EBU36682

Operation on different surfaces and terrains

Go slowly and proceed with caution when operating on an unfamiliar surface or terrain. This vehicle may handle differently in certain types of terrains or on certain surfaces. You may come upon hidden rocks, bumps, or holes without enough time to react. To avoid loss of control or rollover, always be alert to changing surfaces or terrain when operating the vehicle.

8

Your Yamaha YXZ1000ET has higher ground clearance and other features to handle rugged terrain, and as a result, can overturn in situations where some vehicles may not. Abrupt maneuvers or aggressive driving can cause loss of control, including rollovers –

even on flat, open areas. These rollovers can result in crushed limbs and other serious injuries or death to drivers or passengers.

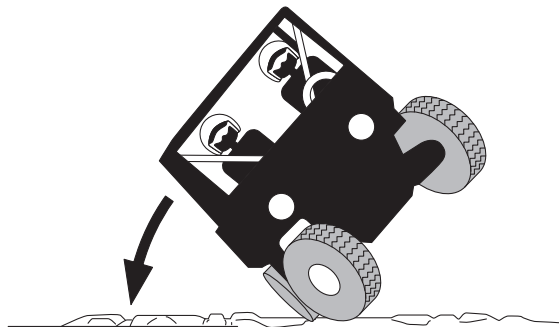

When operating the vehicle in areas which require the use of a safety flag, mount the safety flag pole on the flag pole bracket. See page 5-33.

Hills

Choose carefully which hills you attempt to climb or descend. Avoid hills with slippery surfaces or those where you will not be able to see far enough ahead of you. Use common

sense and remember that some hills are too steep for you to climb or descend. Use proper driving techniques to avoid rearward, forward, or sideways rollovers on hills and slopes.

Drive straight up and down inclines, not across them. If crossing a hill is unavoidable, drive slowly. Turn downhill immediately if you feel the vehicle may tip.

If you think or feel the vehicle may tip or roll:

- Brace yourself by pressing your feet firmly on the floorboard and keep a firm grip on the steering wheel or passenger handhold.
- Do not put your hands or feet outside of the vehicle for any reason.

Uphill

Do not attempt to climb hills until you have mastered basic maneuvers on flat ground. Drive straight up hills, and avoid crossing the side of a hill, which increases your risk of roll-

over. Practice first on gentle slopes before attempting steeper hills. Always check the terrain carefully before attempting any hill.

To climb a hill, you need traction, momentum, and steady throttle. For more traction and control for climbing steeper and/or rougher slopes, shift into low gear and select “4WD” or “DIFF. LOCK”. Travel fast enough to maintain momentum, but not so fast that you cannot react to changes in the terrain as you climb.

Slow down when you reach the crest of the hill if you cannot see clearly what is on the other side – there could be another person, an obstacle, or a sharp drop-off.

If you start to lose traction or momentum when climbing, and decide you will be unable to continue, use the brakes to stop. Do not attempt to turn the vehicle around. With your foot on the brake pedal, look behind you and plan your descent. Shift the transmission into reverse so you can use engine braking to slow your descent. Release the brake, and

then begin to coast down the hill. Use engine braking as much as possible, gently applying the brakes when necessary.

Downhill

Check the terrain carefully before going downhill. When possible, choose a path that lets you drive your vehicle straight downhill. Choose your path carefully and drive slowly enough to be able to react to obstacles that you encounter.

For more traction and control, before going down steeper and/or rougher slopes, shift into low gear and select “4WD” or “DIFF. LOCK”. Engine braking will help you go downhill slowly. Go as slowly as possible. If you begin to go too fast, apply the brakes gently. Avoid hard application of the brakes, which could cause the vehicle to slide.

If you are sliding or skidding, try to steer in the direction the vehicle is sliding, to regain control. For example, if you feel the back of the vehicle start to slide to your right, steer to the right.

If you must turn on the hill to avoid an obstacle, do so slowly and carefully. If the vehicle starts to tip, immediately steer in the downhill direction if there are no obstacles in your path. As you regain proper balance, gradually steer again in the direction you want to go.

Rough terrain

Operation over rough terrain should be done with caution.

- Look for and avoid obstacles that could cause damage to the vehicle or could lead to a rollover or accident.
- Do not drive in a way that will get the vehicle airborne, as injury, loss of control, and damage to the vehicle could occur.

Pavement

This vehicle is designed for off-road use only. Avoid paved surfaces. Turn gradually and go slowly if you must drive on pavement.

Water

If you must cross shallow, slow-moving water up to the depth of the vehicle's floorboard, choose your path carefully to avoid sharp drop-offs, large rocks, or slippery surfaces that could cause the vehicle to overturn. Never operate through water deeper than 40 cm (16 in) or fast-flowing water. Choose a path where both your entrance into and exit point from the water is a gradual incline. Determine the water depth and currents before crossing. Operating this vehicle through deep or fast-flowing water can lead to loss of control or overturn. To reduce your risk of drowning or other injuries, use care when crossing through water.

Wet brakes may have reduced effectiveness. After leaving the water, test the brakes. If necessary, apply the brakes several times to let friction dry them out.

ECB02950

NOTICE

After driving your vehicle in water, be sure to drain the trapped water by removing the check hoses at the bottom of the air filter case. Wash the vehicle in fresh water if it has been operated in salt water or muddy conditions.

Loose terrain/slippery terrain

When driving on slippery terrain, including wet, muddy, or icy conditions, as well as loose gravel, be aware that you could begin skidding or sliding. To avoid loss of control, slow down and put the vehicle in four-wheel drive before driving on a slippery surface and plan your path to avoid making abrupt maneuvers.

If you feel the vehicle begin to slide sideways or fishtail (rear-wheel sliding), steer into the direction of the slide if possible, to regain directional control. For example, if you feel the back of the vehicle start to slide to your right, steer to the right.

Brush or wooded areas

When operating in areas with brush or trees, watch carefully on both sides and above the vehicle for obstacles such as branches that the vehicle might hit, causing an accident. Watch for brush that might enter the vehicle as you pass and strike you or the passenger. Never hold onto the cage/frame. The passenger should always hold onto the passenger handhold with both hands.

The muffler and other engine parts become extremely hot during operation and remain hot after the engine has stopped. To reduce the risk of fire during operation or after leaving the vehicle, do not let brush, grass and other materials collect under the vehicle, near the

muffler or exhaust pipe, or next to other hot parts. Check under the vehicle after operating in areas where combustible materials may have collected. Do not idle or park the vehicle in long dry grass or other dry ground cover.

Encountering obstacles

If you cannot go around an obstacle, such as a fallen tree or a ditch, stop the vehicle where it is safe to do so. Set the parking brake and get out to inspect the area thoroughly. Look from both your approach side and exit side. If you believe you can continue safely, choose the path that will allow you to get over the obstacle and at as close to a right angle as possible to minimize vehicle tipping. Go only fast enough to maintain your momentum but still give yourself plenty of time to react to changes in conditions.

If there is any question about your ability to maneuver safely over the obstacle, you should turn around if the ground is flat and you have the room or back up until you find a less difficult path.

PERIODIC MAINTENANCE AND ADJUSTMENT

Periodic inspection, adjustment, and lubrication will keep your vehicle in the safest and most efficient condition possible. Safety is an obligation of the vehicle owner/operator. The most important points of vehicle inspection, adjustment, and lubrication are explained on the following pages.

WARNING

9 Failure to properly maintain the vehicle or performing maintenance activities incorrectly may increase your risk of injury or death during service or while using the vehicle. If you are not familiar with vehicle service, have a Yamaha dealer perform the service.

WARNING

Turn off the engine when performing maintenance unless otherwise specified.

- A running engine has moving parts that can catch on body parts or clothing and electrical parts that can cause shocks or fires.
 - Running the engine while servicing can lead to eye injury, burns, fire, or carbon monoxide poisoning - possibly leading to death. See page 3-6 for more information about carbon monoxide.
-

WARNING

Brake discs, calipers, drums, and linings can become very hot during use. To avoid possible burns, let brake components cool before touching them.

Owner's Manual and tool kit

You are recommended to put this manual in the vinyl bag and always carry it in the glove compartment as shown. Put the tool kit and tire pressure gauge under the passenger seat.

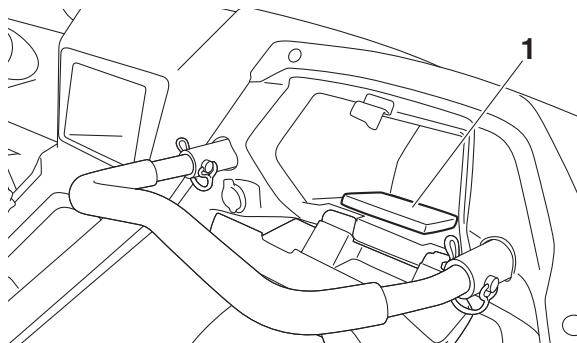

1. Owner's Manual

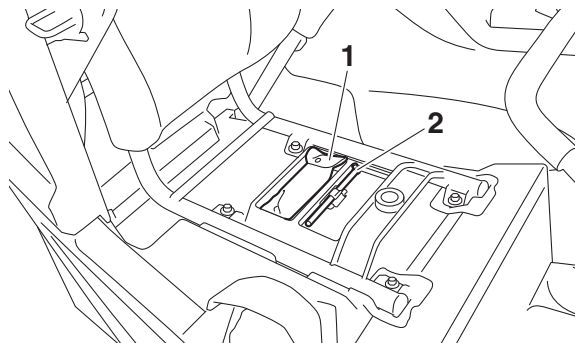

1. Tool kit
2. Tire pressure gauge

The maintenance information included in this manual is intended to provide you, the owner, with the necessary information for completing your own preventive maintenance and minor repairs.

The tools provided in the tool kit are sufficient for this purpose, and should be kept on the vehicle in case of emergency repairs.

Other tools and equipment are required for certain service items. If you do not have a torque wrench available during a service op-

eration requiring one, take your vehicle to a Yamaha dealer to check the torque settings and adjust them as necessary.

Maintenance charts

Even if the vehicle isn't driven for the stated mileage or engine hours, the month maintenance intervals should still be followed. Items marked with an asterisk should be performed by a Yamaha dealer as they require special tools, data and technical skills.

Periodic maintenance chart for the emission control system

NO.	ITEM	ROUTINE	Whichever comes first ⇒	INITIAL			EVERY		
				month	1	3	6	6	12
				km (mi)	240 (150)	1300 (800)	2500 (1600)	2500 (1600)	5000 (3200)
				hours	20	80	160	160	320
1	*	Fuel line	<ul style="list-style-type: none"> • Check fuel hose for cracks or damage. • Replace if necessary. 			√	√	√	
2	*	Valves	<ul style="list-style-type: none"> • Check valve clearance and adjust if necessary. 	Every 5000 km (3200 mi).					
3	*	Spark plugs	<ul style="list-style-type: none"> • Check condition. • Adjust gap and clean. • Replace if necessary. 	√	√	√	√	√	
4	*	Breather system	<ul style="list-style-type: none"> • Check breather hose for cracks or damage. • Replace if necessary. 			√	√	√	
5	*	Fuel injection	<ul style="list-style-type: none"> • Adjust synchronization. 	√	√	√	√	√	

NO.	ITEM	ROUTINE	Whichever comes first ⇒	INITIAL			EVERY		
				month	1	3	6	6	12
				km (mi)	240 (150)	1300 (800)	2500 (1600)	2500 (1600)	5000 (3200)
				hours	20	80	160	160	320
6	*	Exhaust system	<ul style="list-style-type: none"> • Check for leakage. • Check for looseness and tighten all screw clamps and joints if necessary. • Replace gasket(s) if necessary. 			√	√	√	
7	*	Evaporative emission control system	<ul style="list-style-type: none"> • Check control system for damage. • Replace if necessary. 			√	√	√	
8	*	Air induction system	<ul style="list-style-type: none"> • Check the air cut-off valve, reed valve, and hose for damage. • Check condition and clean or replace if necessary. 			√	√	√	
9		Spark arrester	<ul style="list-style-type: none"> • Clean. 			√	√	√	

General maintenance and lubrication chart

NO.	ITEM	ROUTINE	Whichever comes first ⇒	INITIAL			EVERY		
				month	1	3	6	6	12
				km (mi)	240 (150)	1300 (800)	2500 (1600)	2500 (1600)	5000 (3200)
hours	20	80	160	160	320				
1	*	Cooling system	<ul style="list-style-type: none"> • Check coolant leakage. • Repair if necessary. 	√	√	√	√	√	
				<ul style="list-style-type: none"> • Change coolant. 	Every 2 years				
2		Primary air filter (foam)	<ul style="list-style-type: none"> • Clean. • Replace if necessary. 	Every 300–600 km (200–400 mi) (more often in wet or dusty conditions)					
	*	Secondary air filter (paper)	<ul style="list-style-type: none"> • Replace. 	Every 2000–5000 km (1200–3000 mi) (more often in wet or dusty conditions)					
3		Engine oil	<ul style="list-style-type: none"> • Change (warm engine before draining). 	√		√	√	√	
4		Engine oil filter cartridge	<ul style="list-style-type: none"> • Replace. 	√		√		√	
5		Transmission oil	<ul style="list-style-type: none"> • Check oil level and for leakage. 	√	√	√	√	√	
			<ul style="list-style-type: none"> • Change. 	√		√	√	√	
6		Final gear oil	<ul style="list-style-type: none"> • Check oil level. 	√	√	√	√	√	
			<ul style="list-style-type: none"> • Change. 	√				√	

NO.	ITEM	ROUTINE	Whichever comes first ⇒	INITIAL			EVERY		
				month	1	3	6	6	12
				km (mi)	240 (150)	1300 (800)	2500 (1600)	2500 (1600)	5000 (3200)
				hours	20	80	160	160	320
7		Differential gear oil	<ul style="list-style-type: none"> • Check oil level. • Change. 	√	√	√	√	√	
				√				√	
8	*	YCC-S clutch	<ul style="list-style-type: none"> • Check operation and for fluid leakage. • Correct if necessary. 	√	√	√	√	√	
9	*	Brake system	<ul style="list-style-type: none"> • Check operation, brake pad wear, and for fluid leakage. • Correct if necessary, replace pads if worn to the limit. 	√	√	√	√	√	
10	*	Parking brake	<ul style="list-style-type: none"> • Check operation and free play/brake pad wear. • Correct if necessary. Replace pads if worn to the limit. 	√	√	√	√	√	
11	*	Brake fluid and internals	<ul style="list-style-type: none"> • Change the brake fluid. • Replace internal components of master cylinder and calipers. 	Every 2 years					
12	*	Brake hoses	<ul style="list-style-type: none"> • Replace. 	Every 4 years					
13	*	Accelerator pedal	<ul style="list-style-type: none"> • Check operation and free play. 	√	√	√	√	√	

NO.	ITEM	ROUTINE	Whichever comes first ⇒	INITIAL			EVERY		
				month	1	3	6	6	12
				km (mi)	240 (150)	1300 (800)	2500 (1600)	2500 (1600)	5000 (3200)
hours	20	80	160	160	320				
14	*	Wheels	<ul style="list-style-type: none"> • Check balance, runout, and for damage. • Replace if necessary. • Replace wheel if damaged or if runout is over specified limits. 	√		√	√	√	
				<ul style="list-style-type: none"> • Check and tighten the bead lock (for equipped models). 	Every 500 km (300 mi)				
15	*	Wheel bearings	<ul style="list-style-type: none"> • Check bearing assemblies for looseness/damage. • Replace if damaged. 	√		√	√	√	
16	*	Front and rear suspension	<ul style="list-style-type: none"> • Check operation and for oil leakage. • Correct if necessary. 			√		√	
17	*	Steering system	<ul style="list-style-type: none"> • Check operation and for looseness. Replace if damaged. • Check toe-in. Adjust if necessary. 	√	√	√	√	√	
18	*	Stabilizer bushes	<ul style="list-style-type: none"> • Check for cracks or other damage, and replace if necessary. 			√	√	√	
19	*	Upper and lower arm pivots	<ul style="list-style-type: none"> • Lubricate with lithium-soap-based grease. 			√	√	√	
20	*	Rear knuckle upper and lower pivots	<ul style="list-style-type: none"> • Lubricate with lithium-soap-based grease. 			√	√	√	

NO.	ITEM	ROUTINE	Whichever comes first ⇒	INITIAL			EVERY		
				month	1	3	6	6	12
				km (mi)	240 (150)	1300 (800)	2500 (1600)	2500 (1600)	5000 (3200)
				hours	20	80	160	160	320
21	* Drive shaft universal joint	• Lubricate with lithium-soap-based grease.			√	√	√		
22	* Drive shaft seal	• Check for cracks or other damage, and replace if necessary.	Every 1000 km (600 mi)						
23	* Drive shaft spline	• Lubricate with lithium-soap-based grease.	Every 1000 km (600 mi)						
24	* Engine mounts	• Check for cracks or damage. • Check bolt tightness.			√	√	√		
25	* Front and rear axle boots	• Check for cracks or other damage, and replace if necessary.	√				√		
26	* Fittings and fasteners	• Check all chassis fittings and fasteners. • Correct if necessary.	√	√	√	√	√		

EBU35070

TIP

- Inspect and service the vehicle more frequently if you drive aggressively or in severe conditions such as rain, mud, sand or unusually dusty areas.
- Service the clutch system in similar fashion and at similar intervals to the brake system.

- The service items contained herein should not be considered exhaustive, therefore:
 - have your YXZ1000ET checked and serviced by your Yamaha dealer at regular intervals.
 - replace any damaged or visibly worn part immediately.
-

Hood

To remove

Remove the bolts, and then pull the hood off as shown.

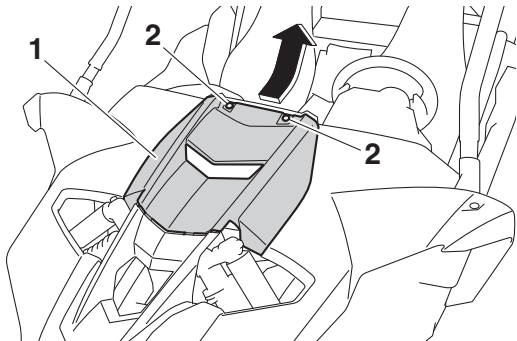

9

1. Hood
2. Bolt

To install

Place the hood in the original position, and then install the bolts.

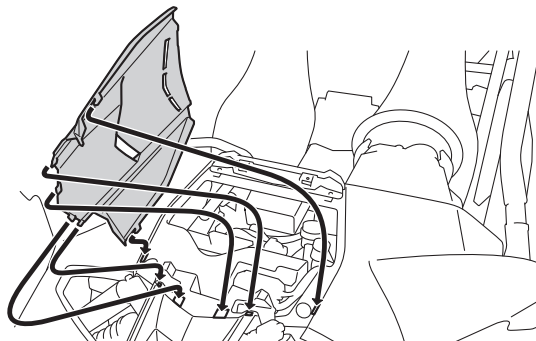

EBU36932

Panels

The panels shown need to be removed to perform some of the maintenance jobs described in this chapter. Refer to this section each time a panel needs to be removed and installed.

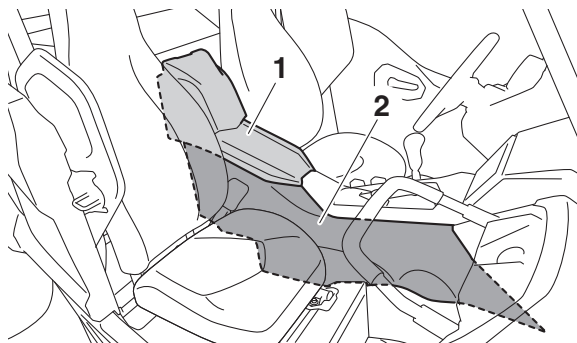

1. Panel A
2. Panel B

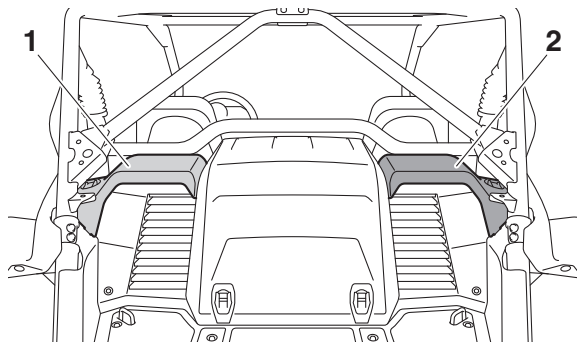

1. Panel C
2. Panel D

Panel A

To remove the panel

1. Unhook the projections as shown.

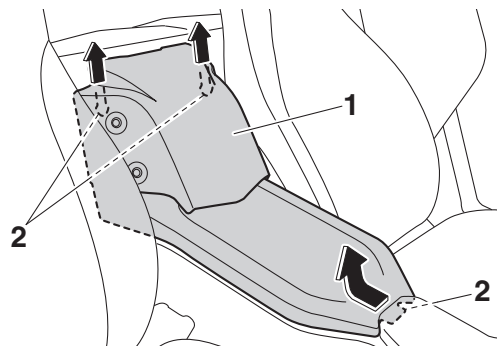

1. Panel A
2. Projection

2. Disconnect the interior light couplers (equipped models), and then remove the panel.

For interior-light-equipped models

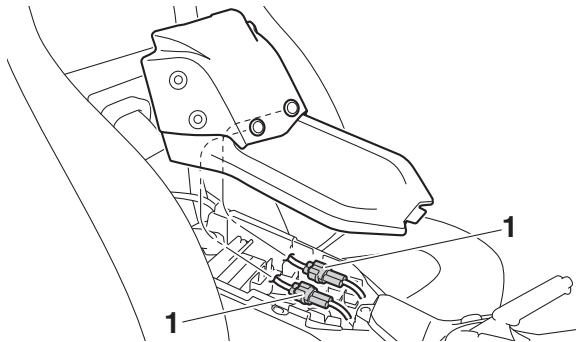

1. Interior light coupler

To install the panel

1. Connect the interior light couplers. (equipped models)
2. Place the panel in the original position.

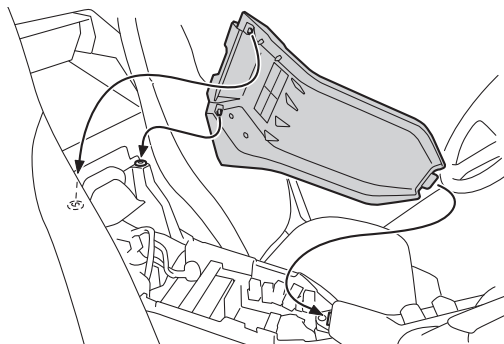

Panel B

To remove the panel

1. Remove the hood. (See page 9-11.)
2. Remove panel A.
3. Remove the top cover by removing the quick fastener screw and the bolts.

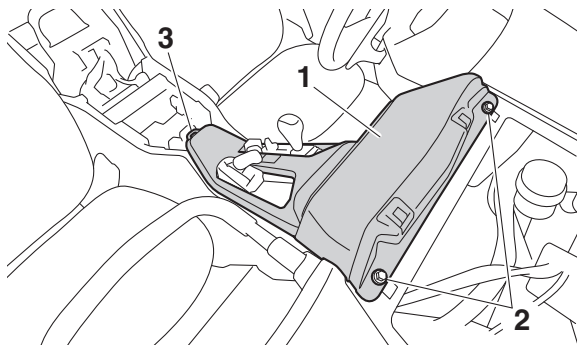

1. Top cover
2. Bolt
3. Quick fastener screw

4. Remove the passenger seat cushion.
(See page 5-26.)
5. Remove the passenger seat by removing
the bolts.

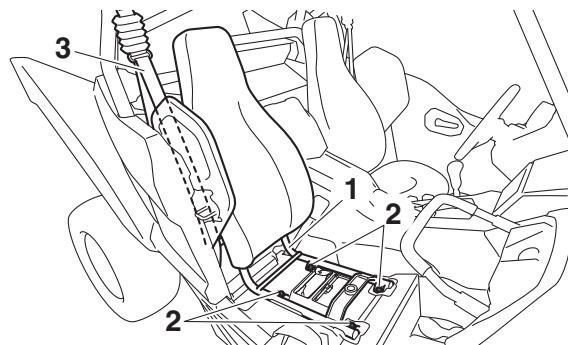

1. Passenger seat
2. Bolt
3. Seat belt

6. Remove the quick fastener screws and
the bolts, and then pull the panel off as
shown.

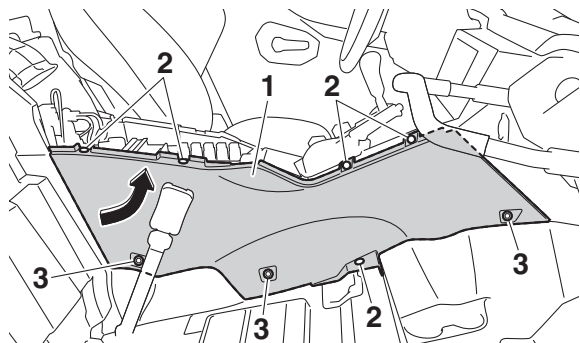

1. Panel B
2. Quick fastener screw
3. Bolt

To install the panel

1. Place the panel in the original position, and then install the bolts and the quick fastener screws.

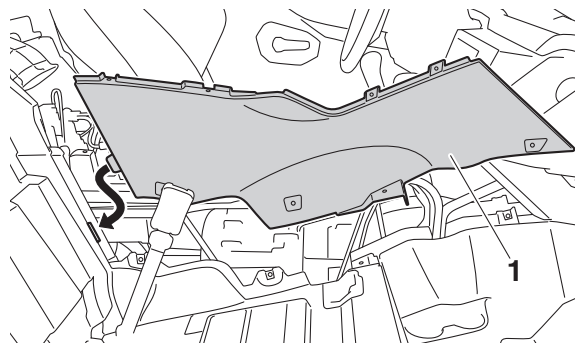

1. Panel B
2. Install the passenger seat by installing the bolts, and then tighten them to the specified torque.

Tightening torque:
 Passenger seat bolt:
 32 N·m (3.2 kgf·m, 24 lb·ft)

TIP

- Make sure that the seat frame is properly secured.

- Place the passenger seat belt in the original position.

3. Install the passenger seat cushion.
4. Install the top cover by installing the bolts and quick fastener screw.
5. Install panel A and the hood.

Panels C and D

To remove a panel

1. Pull the tab on the panel lock up, and then turn the panel lock 1/4 turn clockwise.

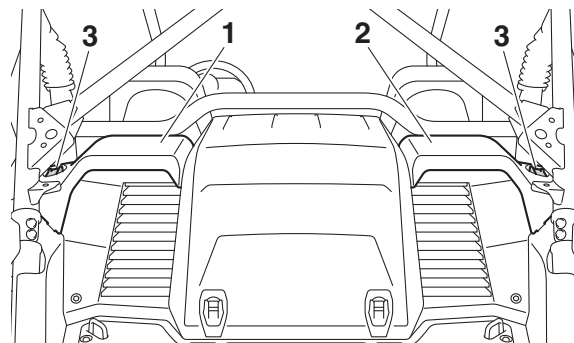

1. Panel C
2. Panel D
3. Tab

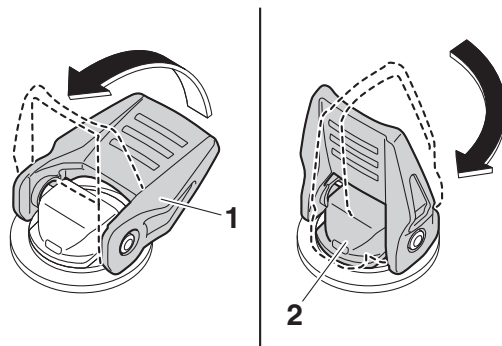

1. Tab
2. Panel lock

2. Remove the panel as shown.

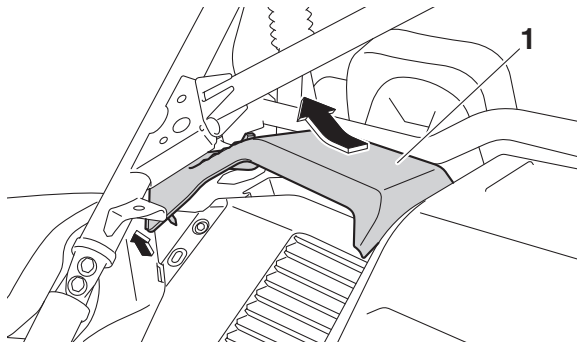

1. Panel C

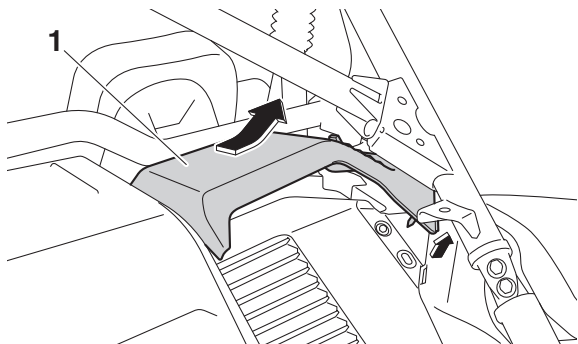

1. Panel D

To install a panel

1. Place the panel in the original position.

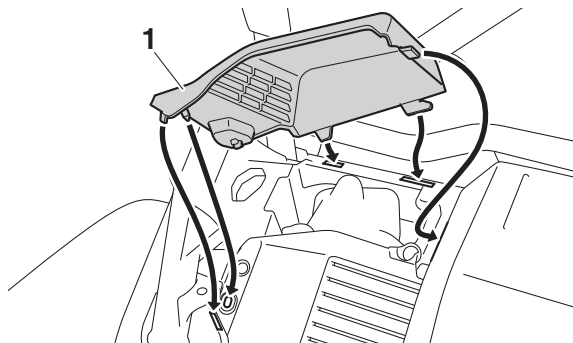

1. Panel C

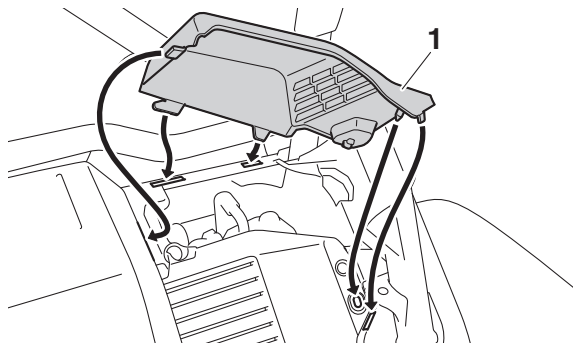

1. Panel D

2. Turn the panel lock 1/4 turn counter-clockwise, and then push the tab on the panel lock down so that it is pointing rearward.

EBU3543A

Engine oil and oil filter

Check the engine oil level before each operation. In addition, change the oil and the oil filter cartridge at the intervals specified in the periodic maintenance chart.

Recommended engine oil:

YAMALUBE

5W-30, 10W-30, 10W-40, 15W-40, 20W-40, 20W-50

Oil quantity:

Oil change only:

2.50 L (2.64 US qt, 2.20 Imp.qt)

Oil change and filter replacement:

2.70 L (2.85 US qt, 2.38 Imp.qt)

ECB03020

NOTICE

- **Do not use oils with a diesel specification of “CD” or oils of a higher quality than specified. In addition, do not use oils labeled “ENERGY CONSERVING II” or higher.**
- **Make sure that no foreign material enters the oil tank.**

To check the engine oil level

1. Park the vehicle on a level surface.
2. Remove panel D. (See page 9-11.)
3. Start the engine and warm it up to a normal operating temperature (the engine oil temperature should reach 60 °C [140 °F]), then let the engine idle for a minimum of ten seconds before turning the engine off.

TIP

If the engine is cold, take the vehicle for a short drive or let it idle for approximately ten minutes before checking the engine oil level.

4. Remove the engine oil tank filler cap and wipe the dipstick with a clean rag.

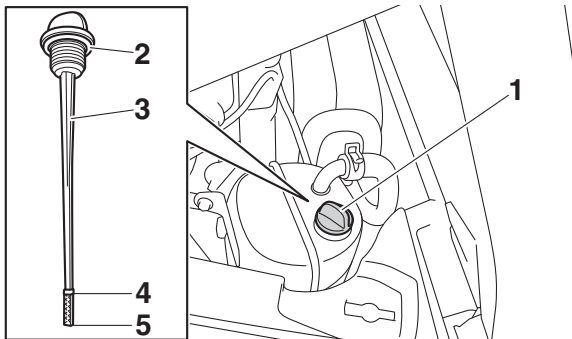

1. Engine oil tank filler cap
2. O-ring
3. Engine oil dipstick
4. Maximum level mark
5. Tip of the engine oil dipstick

5. Insert the dipstick back into the oil tank (without screwing it in), and then remove it again to check the oil level.
6. If the oil level is below the tip of the dipstick, add oil.

TIP _____
Add oil a little at a time so as not to overfill beyond the maximum level mark.

7. Check the O-ring for damage, and replace it if necessary.
8. Install the engine oil tank filler cap.
9. Install the panel.

To change the engine oil

1. Park the vehicle on a level surface.
2. Remove panel D. (See page 9-11.)
3. Remove the engine oil tank cover by removing the bolts.

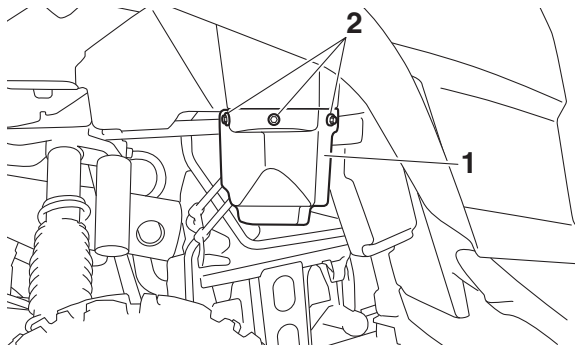

1. Engine oil tank cover
2. Bolt



1. Engine oil tank filler cap

4. Start the engine, warm it up for several minutes, and then turn it off.
5. Remove the engine oil tank filler cap and the cylinder head cap.

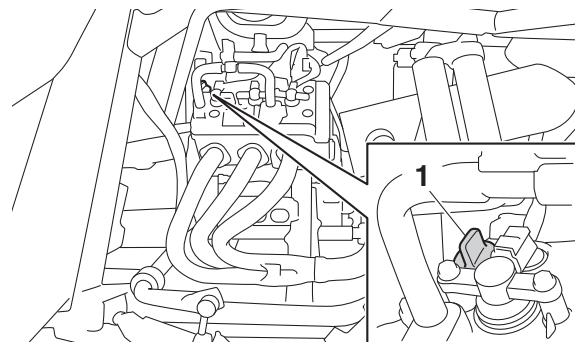

1. Cylinder head cap

6. Place an oil pan under the oil tank to collect the used engine oil.

7. Remove the oil tank drain bolt and used gasket.

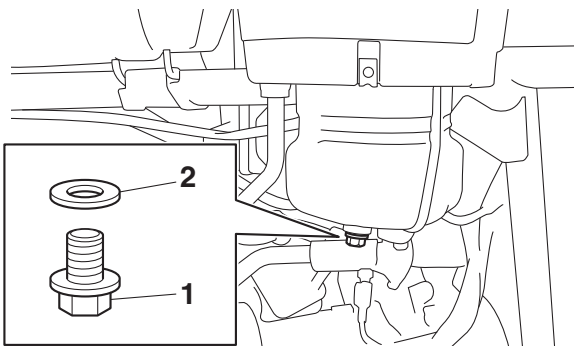

1. Engine oil tank drain bolt
2. Gasket

8. Place an oil pan under the engine to collect the used engine oil.
9. Remove the engine oil drain bolt and used gasket.

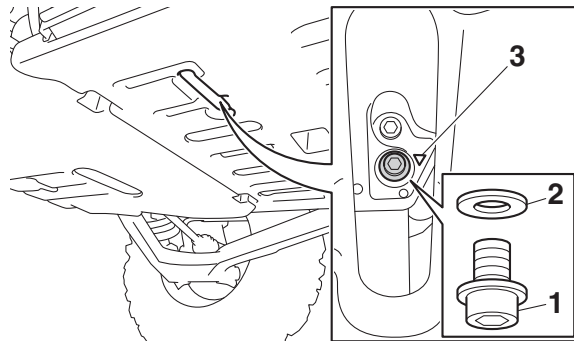

1. Engine oil drain bolt
2. Gasket
3. "▽" mark

TIP

A "▽" mark is stamped on the crankcase near the engine oil drain bolt.

10. Install the engine oil drain bolt with new gasket, the oil tank drain bolt with new gasket, and then tighten the bolts to the specified torques.

Tightening torques:

Engine oil drain bolt:

10 N·m (1.0 kgf·m, 7.4 lb·ft)

Engine oil tank drain bolt:

16 N·m (1.6 kgf·m, 12 lb·ft)

11. Add 2.00 L (2.11 US qt, 1.76 Imp.qt) of the recommended engine oil to the oil tank.

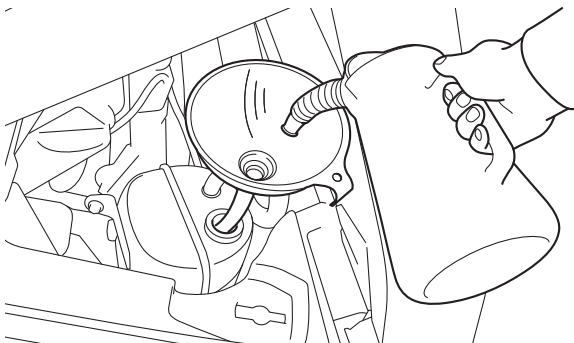

12. Check the O-ring for damage, and replace it if necessary.

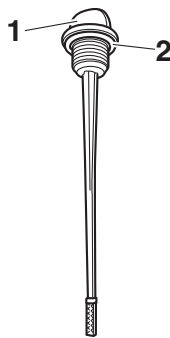

1. Engine oil tank filler cap
2. O-ring
3. Cylinder head cap

13. Install and tighten the engine oil tank filler cap and the cylinder head cap.
14. Start the engine, warm it up for several minutes, and then turn it off.
15. Remove the engine oil tank filler cap, and then add sufficient oil of the recommended type to raise it to the maximum level mark on the dipstick.

TIP

Be sure to wipe off spilled oil on any parts after the engine and exhaust system have cooled down.

16. Install and tighten the engine oil tank filler cap.
17. Start the engine and let it idle for several minutes. During this time, check for oil leakage. If any oil leaks are found, stop the engine and check for the cause.
18. Stop the engine, wait at least ten minutes, and then check the oil level one last time.
19. Install the engine oil tank cover by installing the bolts.
20. Install the panel.

9

To change the engine oil and oil filter

1. Park the vehicle on a level surface.
2. Loosen the left and right side panels by removing the bolt as shown.

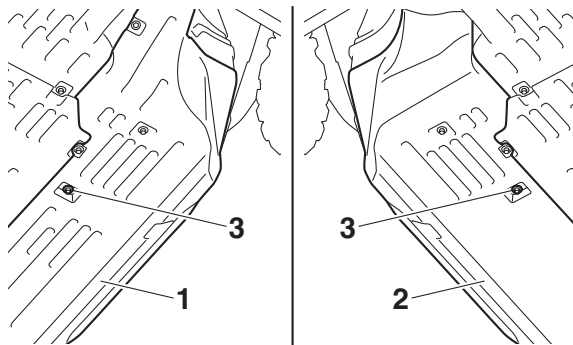

1. Left side panel
2. Right side panel
3. Bolt

3. Remove the rear bottom panel by removing the bolts.

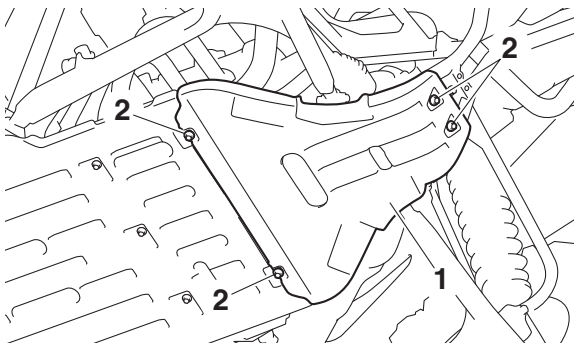

- 1. Rear bottom panel
- 2. Bolt

4. Remove the bolts, and then slide the center bottom panel rearward to remove it.

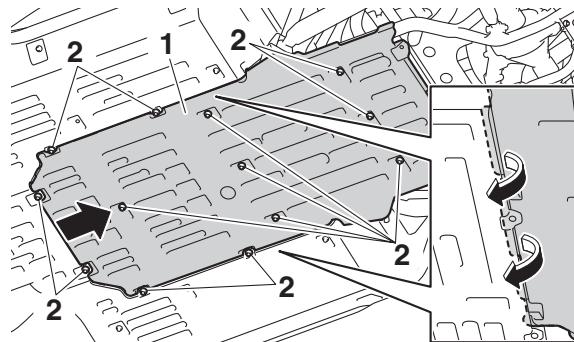

- 1. Center bottom panel
- 2. Bolt

5. Follow steps 2–9 of the “To change the engine oil” section for the oil draining procedure.
6. Remove the oil filter cartridge with an oil filter wrench. Make sure the O-ring is removed together with the oil filter cartridge. If the O-ring remains attached to the crankcase, oil leakage may occur.

TIP _____
An oil filter wrench is available from a Yamaha dealer.

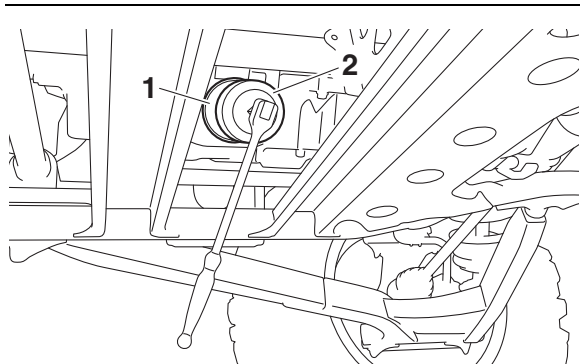

1. Oil filter cartridge
2. Oil filter wrench

9

7. Apply a light coat of clean engine oil to the O-ring of the new oil filter cartridge.

TIP _____
Make sure that the O-ring is properly seated.

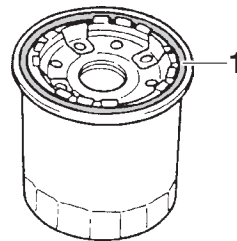

1. O-ring

8. Install the new oil filter cartridge, and then tighten to the specified torque.

Tightening torque:
Oil filter cartridge:
17 N·m (1.7 kgf·m, 13 lb·ft)

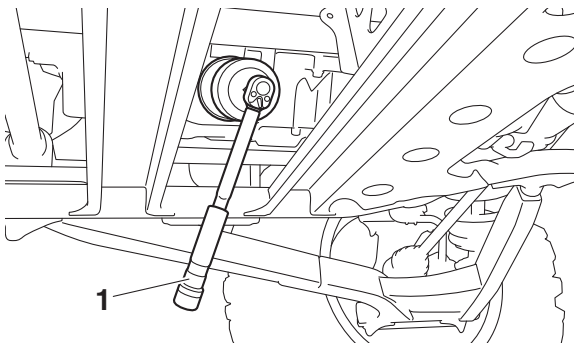

1. Torque wrench

9. Follow steps 10–20 of the “To change the engine oil” section for the oil filling procedure.
10. Slide the front portion of the center bottom panel into place as shown, and then hook the left and right sides of the center bottom panel into place.

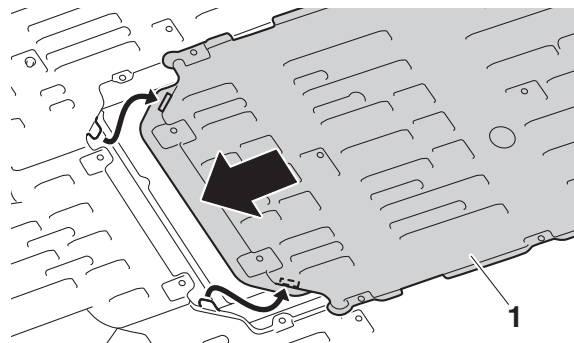

1. Center bottom panel

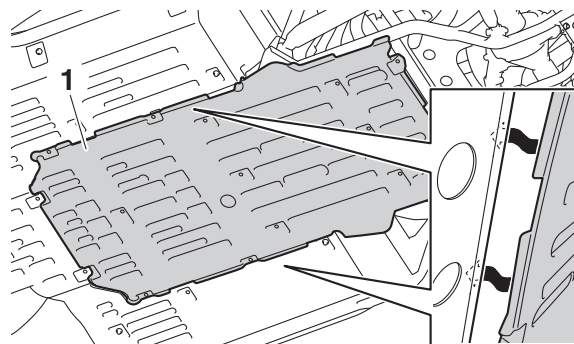

1. Center bottom panel

11. Install the center bottom panel bolts, and then tighten them to the specified torque.

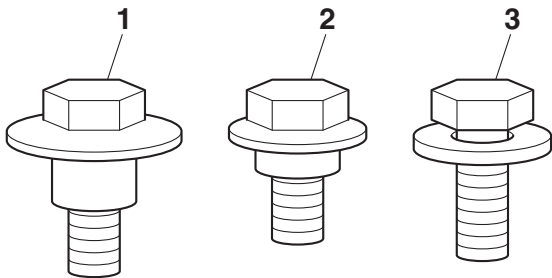

- 1. Bolt A
- 2. Bolt B
- 3. Bolt C

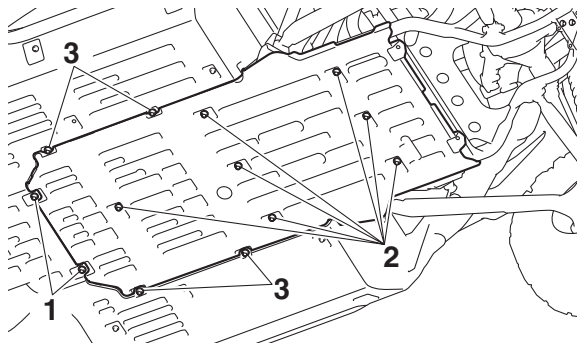

- 1. Bolt A
- 2. Bolt B
- 3. Bolt C

Tightening torques:

Bolt A:

7 N·m (0.7 kgf·m, 5.2 lb·ft)

Bolt B:

7 N·m (0.7 kgf·m, 5.2 lb·ft)

Bolt C:

7 N·m (0.7 kgf·m, 5.2 lb·ft)

- 12. Install the rear bottom panel by installing the bolts, and then tightening them to the specified torque.

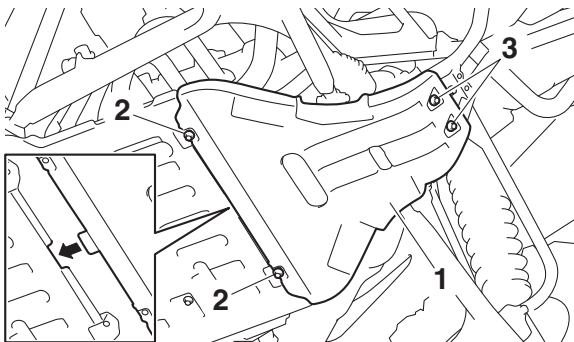

- 1. Rear bottom panel
- 2. Bolt A
- 3. Bolt B

Tightening torques:

Bolt A:

7 N·m (0.7 kgf·m, 5.2 lb·ft)

Bolt B:

7 N·m (0.7 kgf·m, 5.2 lb·ft)

- 13. Install the side panel bolts, and then tighten them to the specified torque.

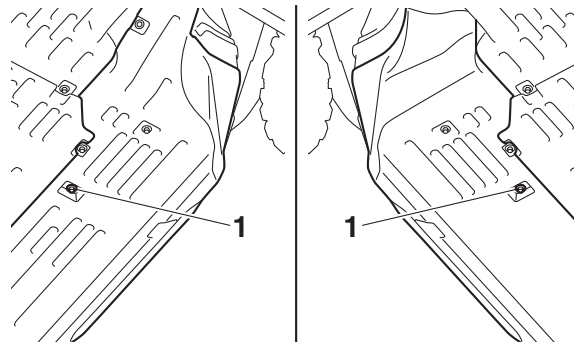

- 1. Bolt B

Tightening torque:

Bolt B:

7 N·m (0.7 kgf·m, 5.2 lb·ft)

EBU38630

Why Yamalube

YAMALUBE oil is a Genuine YAMAHA Part born of the engineers' passion and belief that engine oil is an important liquid engine component. We form teams of specialists in the fields of mechanical engineering, chemistry, electronics and track testing, and have them develop the engine together with the oil it will

use. Yamalube oils take full advantage of the base oil's qualities and blend in the ideal balance of additives to make sure the final oil clears our performance standards. Thus, Yamalube mineral, semisynthetic and synthetic oils have their own distinct characters and value. Yamaha's experience gained over many years of research and development into oil since the 1960's helps make Yamalube the best choice for your Yamaha engine.



9

EBU35108

Transmission oil

Check the oil level and change the transmission oil at the intervals specified in the periodic maintenance chart.

ECB02910

NOTICE

When checking or changing the transmission oil, make sure that no foreign material enters the transmission. If necessary, clean the filler cap and surrounding area.

Recommended oil:

YAMALUBE

SAE 5W-30, 10W-30, 10W-40, 15W-40,
20W-40 or 20W-50

Oil quantity:

1.50 L (1.59 US qt, 1.32 Imp.qt)

To check the transmission oil level

1. Park the vehicle on a level surface.
2. Remove panel B. (See page 9-11.)
3. Remove the transmission oil filler cap, wipe the dipstick clean, insert it back into the transmission case (without screwing it in), and then remove it again.

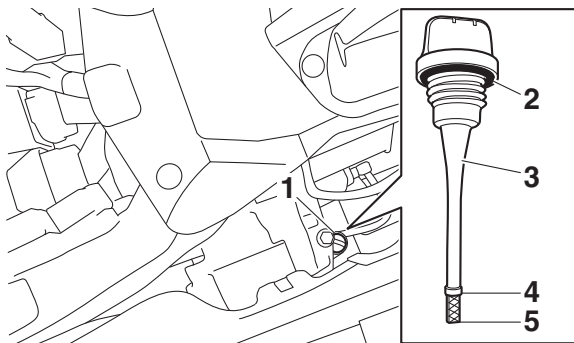

1. Transmission oil filler cap
2. O-ring
3. Dipstick
4. Maximum level mark
5. Tip of the dipstick

TIP

The transmission oil level should be between the tip of the dipstick and the maximum level mark.

4. If the oil level is at or below the tip of the dipstick, add oil.

TIP

Add a sufficient amount to raise to the maximum level mark, but do not overfill.

5. Check the O-ring for damage, and replace it if necessary.
6. Install the transmission oil filler cap.
7. Install the panel.

To change the transmission oil

1. Place an oil pan under the transmission case to collect the used oil.
2. Remove the transmission oil filler cap.
3. Remove the transmission oil drain bolt and gasket.

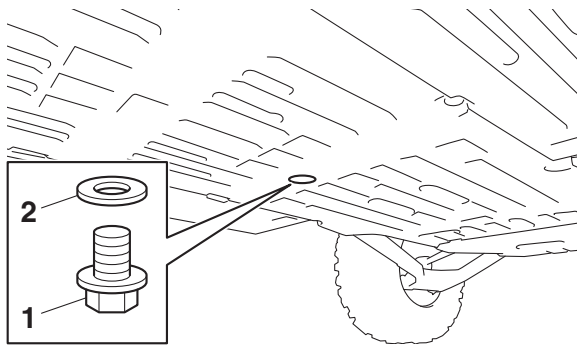

1. Transmission oil drain bolt
2. Gasket

TIP _____
Oil will flow out immediately when the drain bolt is loosened. Take care not to lose the bolt.

4. After draining the oil, install the transmission oil drain bolt with a new gasket.
5. Tighten the drain bolt to the specified torque.

Tightening torque:
Transmission oil drain bolt:
20 N·m (2.0 kgf·m, 15 lb·ft)

6. Check the O-ring for damage, and replace it if necessary.
7. Refill the transmission with the specified amount of the recommended oil.
8. Install the transmission oil filler cap.
9. Start the engine and let it idle while checking for oil leakage.
10. Stop the engine and check the oil level one last time.

EBU36055

Final gear oil

Check the oil level and change the final gear oil at the intervals specified in the periodic maintenance chart.

NOTICE

When checking or changing the final gear oil, make sure that no foreign material enters the final gear case. If necessary, clean the final gear oil filler bolt and surrounding area.

Recommended oil:

YAMALUBE

SAE 80W-90 API GL-5 Hypoid gear oil

Oil quantity:

0.47 L (0.50 US qt, 0.41 Imp.qt)

Checking the final gear oil level

1. Park the vehicle on a level surface.
2. Remove the final gear oil filler bolt and its gasket, and then check the oil level in the final gear case. The oil level should be at the brim of the filler hole.

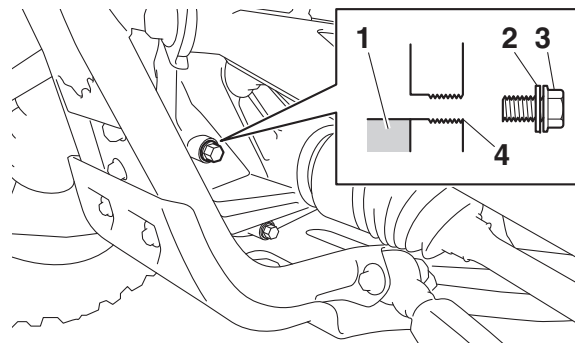

1. Final gear oil
2. Gasket
3. Final gear oil filler bolt
4. Correct oil level

3. If the oil is below the brim of the filler hole, add sufficient oil of the recommended type to raise it to the correct level.
4. Check the gasket for damage, and replace it if necessary.
5. Install the oil filler bolt and its gasket, and then tighten the bolt to the specified torque.

Tightening torque:

Final gear oil filler bolt:

22 N·m (2.2 kgf·m, 16 lb·ft)

Changing the final gear oil

1. Park the vehicle on a level surface.
2. Place an oil pan under the final gear case to collect the used oil.
3. Remove the final gear oil filler bolt, the final gear oil drain bolt and their gasket to drain the oil.

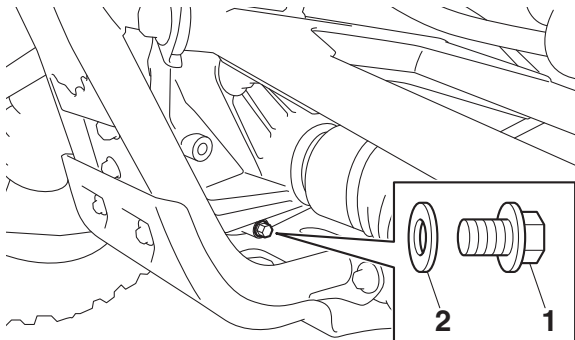

1. Final gear oil drain bolt

2. Gasket

4. Install the drain bolt and its new gasket, and then tighten the bolt to the specified torque.

Tightening torque:

Final gear oil drain bolt:

22 N·m (2.2 kgf·m, 16 lb·ft)

5. Refill with the recommended final gear oil up to the brim of the filler hole.
6. Check the oil filler bolt gasket for damage, and replace it if necessary.
7. Install the oil filler bolt and its gasket, and then tighten the bolt to the specified torque.

Tightening torque:

Final gear oil filler bolt:

22 N·m (2.2 kgf·m, 16 lb·ft)

8. Check for oil leakage. If oil leakage is found, check for the cause.

Differential gear oil

Check the oil level and change the differential gear oil at the intervals specified in the periodic maintenance chart.

NOTICE

When checking or changing the differential gear oil, make sure that no foreign material enters the differential gear case. If necessary, clean the differential gear oil filler bolt and surrounding area.

Recommended oil:

YAMALUBE

SAE 80W-90 API GL-5 Hypoid gear oil

Oil quantity:

0.18 L (0.19 US qt, 0.16 Imp.qt)

Checking the differential gear oil level

1. Park the vehicle on a level surface.

2. Remove the differential gear oil filler bolt and its gasket, and then check the oil level. It should be up to the brim of the filler hole.

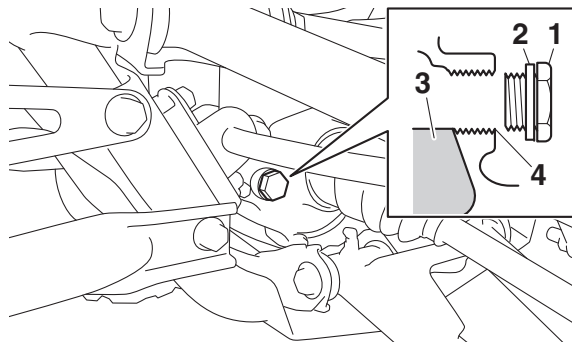

1. Differential gear oil filler bolt
2. Gasket
3. Differential gear oil
4. Correct oil level

3. If the level is low, add sufficient oil of the recommended type to raise it to the specified level.
4. Check the gasket for damage, and replace it if necessary.

5. Install the differential gear oil filler bolt and its gasket, and then tighten the bolt to the specified torque.

Tightening torque:

Differential gear oil filler bolt:
23 N·m (2.3 kgf·m, 17 lb·ft)

Changing the differential gear oil

1. Park the vehicle on a level surface.
2. Place an oil pan under the differential gear case to collect the used oil.
3. Remove the differential gear oil filler bolt, the differential gear oil drain bolt and their gasket to drain the oil.

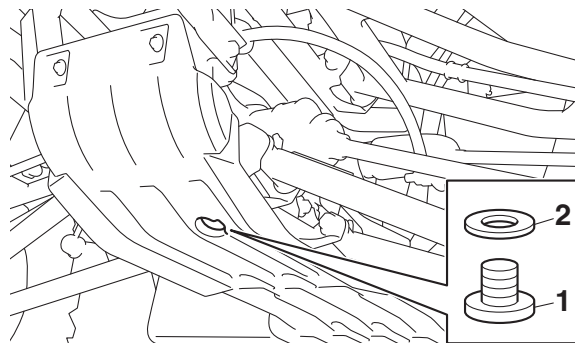

1. Differential gear oil drain bolt
2. Gasket

4. Install the differential gear oil drain bolt and its new gasket, and then tighten the bolt to the specified torque.

Tightening torque:

Differential gear oil drain bolt:
9.8 N·m (0.98 kgf·m, 7.2 lb·ft)

5. Refill the differential gear case with the recommended oil.
6. Check the oil filler bolt gasket for damage, and replace it if necessary.

7. Install the differential gear oil filler bolt and its gasket, and then tighten the bolt to the specified torque.

Tightening torque:

Differential gear oil filler bolt:
23 N·m (2.3 kgf·m, 17 lb·ft)

8. Check for oil leakage. If oil leakage is found, check for the cause.

EBU35112

Coolant

The coolant level should be checked regularly. In addition, the coolant must be changed at the intervals specified in the periodic maintenance chart.

Recommended coolant:

YAMALUBE coolant

Coolant quantity:

Coolant reservoir (up to full level):
0.56 L (0.59 US qt, 0.49 Imp.qt)

Radiator (including all routes):
3.78 L (4.00 US qt, 3.33 Imp.qt)

TIP

If genuine Yamaha coolant is not available, use an ethylene glycol antifreeze containing corrosion inhibitors for aluminum engines and mix with distilled water at a 1:1 ratio.

ECB02190

NOTICE

Mix antifreeze with distilled water only. However, if distilled water is not available, soft water may be used for refilling. Do not use hard water or salt water since they are harmful to the engine.

To check the coolant level

1. Park the vehicle on a level surface.
2. Wait for the engine to cool for an accurate reading.
3. Look at the coolant level in the coolant reservoir.

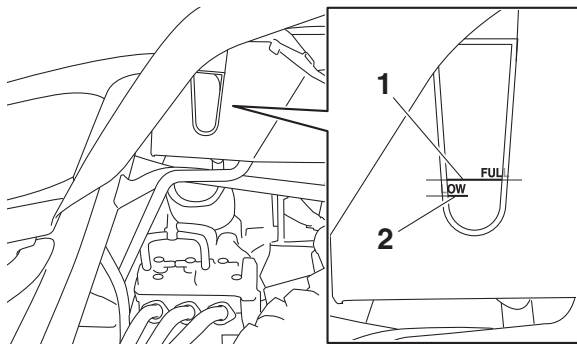

1. Maximum level mark
2. Minimum level mark

4. If the coolant is at or below the minimum level mark, remove panel C. (See page 9-11.)

9

5. Remove the coolant reservoir cap, add coolant up to the maximum level mark, and then install the cap. **NOTICE: If coolant is not available, use distilled water or soft tap water instead. Do not use hard water or salt water since they are harmful to the engine. If water has been used instead of coolant, replace**

it with coolant as soon as possible, otherwise the cooling system will not be protected against frost and corrosion. If water has been added to the coolant, have a Yamaha dealer check the antifreeze content of the coolant as soon as possible, otherwise the effectiveness of the coolant will be reduced. [ECB01012]

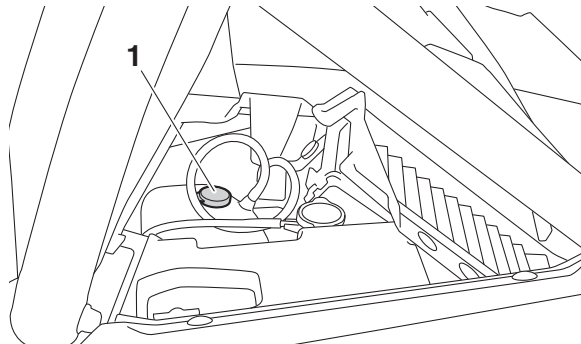

1. Coolant reservoir cap

6. Install the panel when finished servicing the vehicle.

To change the coolant

The coolant must be changed at the intervals specified in the periodic maintenance chart. Have a Yamaha dealer change the coolant.

WARNING! Never attempt to remove the radiator cap when the engine is hot. [EWB04250]

EBU32400

Axle boots

Check the axle boots for holes or tears.

If any damage is found, have them replaced by a Yamaha dealer.

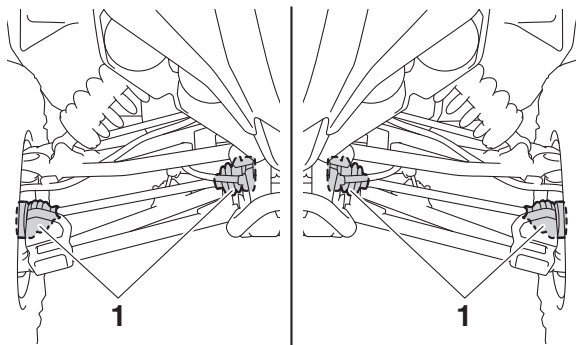

1. Front axle boot

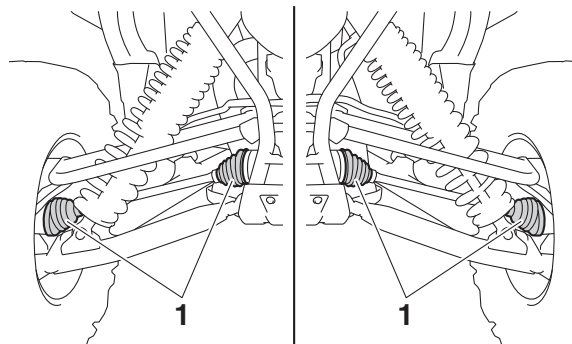

1. Rear axle boot

EBU35121

Checking the spark plugs

The spark plug is an important engine component which should be periodically checked, preferably by a Yamaha dealer. Since heat and deposits will cause any spark plug to slowly erode, the spark plugs should be removed and checked in accordance with the periodic maintenance chart for the emission control system. In addition, the condition of the spark plugs can reveal the condition of the engine.

The porcelain insulator around the center electrode of each spark plug should be a medium-to-light tan color (the ideal color when the vehicle is ridden normally), and all spark plugs installed in the engine should have a similar color. If any spark plug shows a distinctly different color, the engine could be operating improperly. Do not attempt to diagnose such problems yourself. Instead, have a Yamaha dealer check the vehicle.

If a spark plug shows signs of electrode erosion and excessive carbon or other deposits, it should be replaced.

9

Specified spark plug:
NGK/CR9EB

Before installing a spark plug, the spark plug gap should be measured with a wire thickness gauge and, if necessary, adjusted to specification.

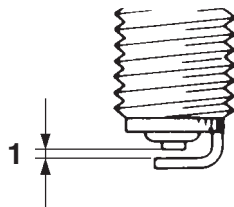

1. Spark plug gap

Spark plug gap:
0.7–0.8 mm (0.028–0.031 in)

Clean the surface of the spark plug gasket and its mating surface, and then wipe off any grime from the spark plug threads.

Tightening torque:
Spark plug:
13 N·m (1.3 kgf·m, 9.6 lb·ft)

TIP

If a torque wrench is not available when installing the spark plug, a good estimate of the correct torque is 1/4–1/2 turn past finger tight. However, the spark plug should be tightened to the specified torque as soon as possible.

ECB02900

NOTICE

Do not use any tools to remove or install the spark plug cap, otherwise the ignition coil coupler may be damaged. The spark plug cap may be difficult to remove because the rubber seal on the end of the cap fits tightly. To remove the spark plug cap, simply twist it back and forth while pulling it out; to install it, twist it back and forth while pushing it in.

EBU38320

Air filter maintenance

This model is equipped with two air filter elements, a primary foam-type air filter and a secondary paper-type air filter.

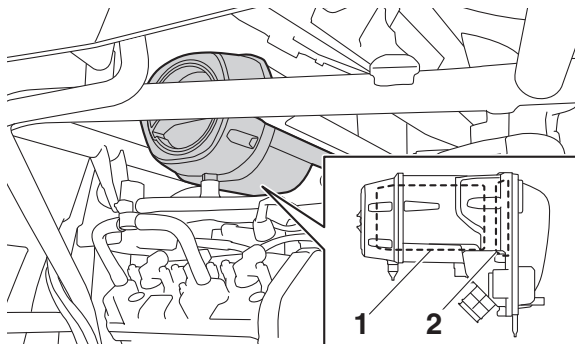

1. Primary air filter
2. Secondary air filter

The primary air filter is easily accessed and should be cleaned and oiled every 300–600 km (200–400 mi).

The secondary air filter is more difficult to access, cannot be cleaned, and should be replaced by a Yamaha dealer every 2000–5000 km (1200–3000 mi).

TIP _____
Service the air filters more frequently when operating in wet or dusty environments.

Whenever air filter maintenance is performed:

- check the air inlet for obstructions and the air filter case for dirt and foreign matter.
- check the air filter case check hoses for dirt or water and clean as necessary.
- check the air filter case joints and the rubber joints to and from the throttle body for proper fit and sealing.
- tighten all fittings securely to avoid the possibility of unfiltered air entering the engine.

ECB02270

9

NOTICE _____
Never operate the engine with the air filter element removed. Doing so would allow unfiltered air to enter, causing rapid engine wear and possible engine damage.

Additionally, the fuel injection system would be affected, resulting in poor engine performance and possible overheating.

Clean the primary air filter as follows.

1. Remove the air filter case cover by turning the air filter case cover lock counter-clockwise.

TIP _____
Make sure that the match mark on the cover lock is aligned with the open match mark on the air filter case cover.

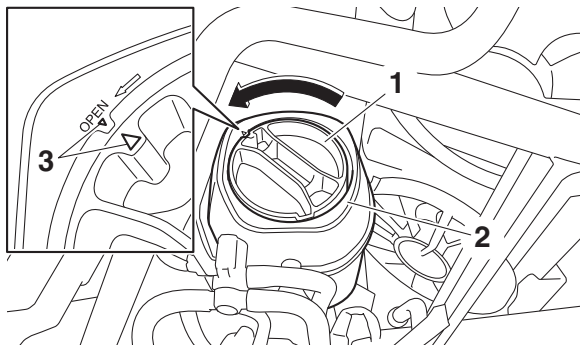

1. Air filter case cover lock
2. Air filter case cover
3. Match mark

2. Remove the foam air filter.

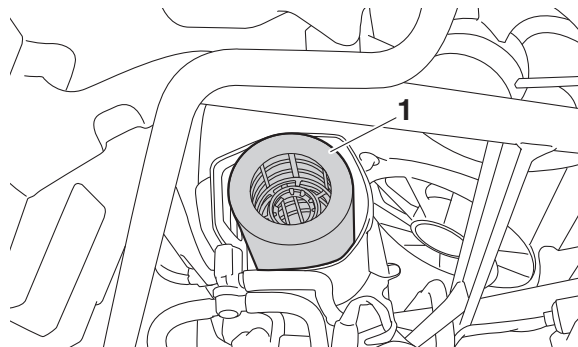

1. Foam air filter

3. Remove the foam air filter element from the air filter frame.

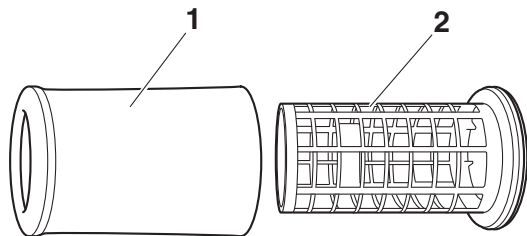

1. Foam air filter element
2. Air filter frame

4. Wash the foam material gently but thoroughly in parts cleaning solvent. **WARNING! Using gasoline or other flammable solvents to clean the air filter element can cause a fire or explosion, which could lead to serious injury.** [EWB03360]
5. Squeeze out the excess solvent. **NOTICE: Do not twist the foam material when squeezing it.** [ECB02970]

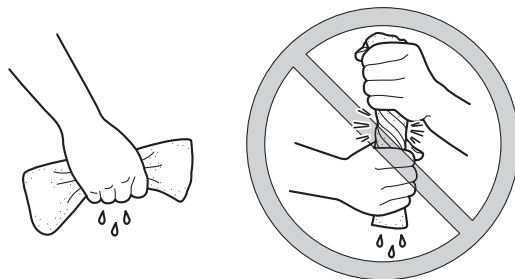

6. Wash the foam material in warm soapy water to remove remaining solvent, then rinse thoroughly with plain warm water.
7. Squeeze out the excess water. **NOTICE: Do not twist the foam material when squeezing it.** [ECB02970]
8. Allow the foam air filter to dry thoroughly. Inspect for wear and tear and replace if damaged or heavily worn.

9. Thoroughly apply Yamalube foam air filter oil (or other quality liquid foam air filter—do not use a spray-type product) to the foam material. The foam air filter element should be wet but not dripping.
10. Pull the foam air filter element over its frame.
11. Install the air filter.
12. Install the air filter case cover and lock it into place by turning the air filter case cover lock clockwise.

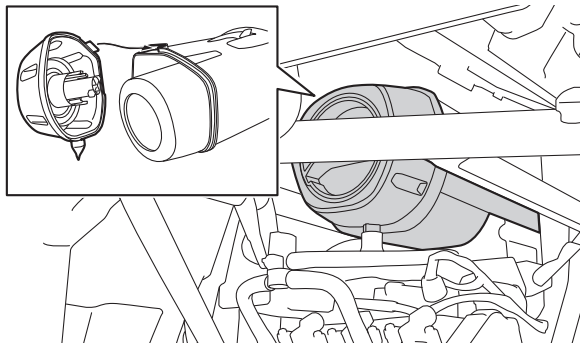

TIP

Make sure that the match mark on the cover lock is aligned with the close match mark on the air filter case cover.

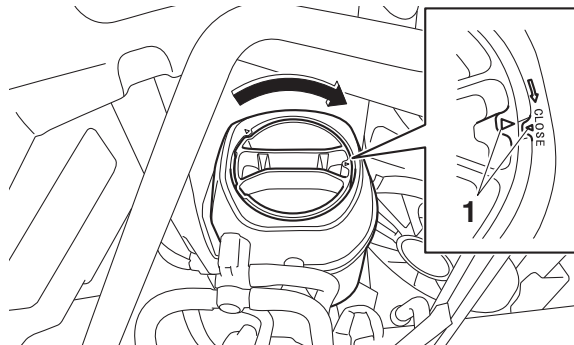

1. Match mark

EBU35130

Cleaning the air filter case check hoses

There is a check hose on each side of the air filter case. If dust or water collects in a check hose, empty the hose and clean the air filter element and air filter case.

Cleaning the spark arrester



Hot exhaust system may cause burns. To avoid burns or fires, make sure that the engine is stopped and the exhaust system is cool before cleaning the spark arrester. Do not start the engine while cleaning the exhaust system.

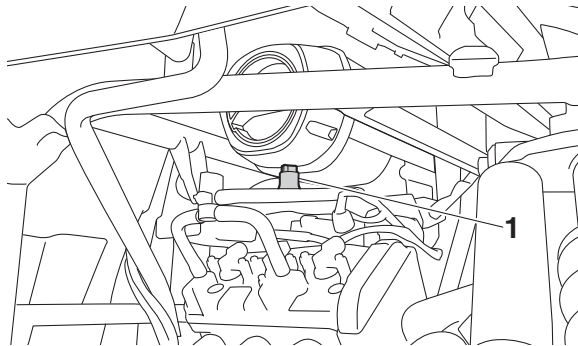

1. Air filter case check hose

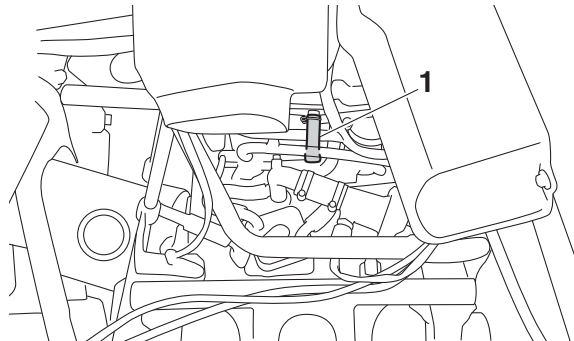

1. Air filter case check hose

1. Remove the tailpipe cover by removing the tailpipe cover bolts.

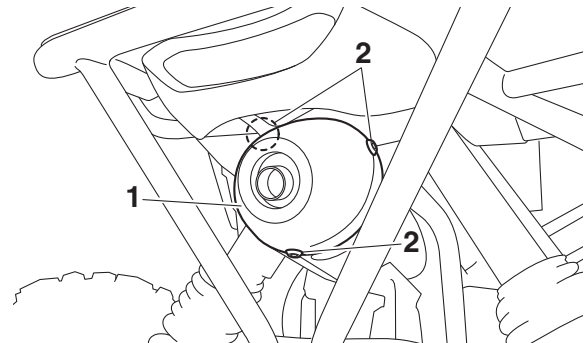

1. Tailpipe cover
2. Tailpipe cover bolt

2. Remove the tailpipe bolts.

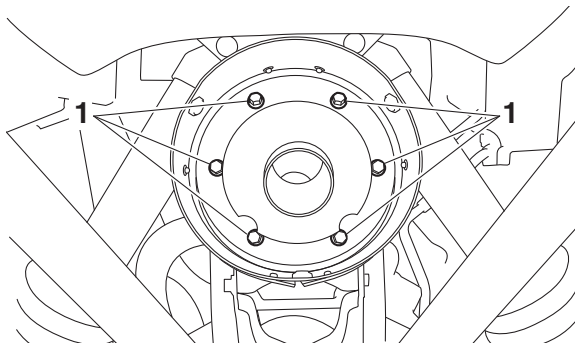

1. Tailpipe bolt

3. Remove the tailpipe by pulling it out of the muffler, and then remove the gasket.
4. Tap the tailpipe lightly, and then use a wire brush to remove any carbon deposits from the spark arrester portion of the tailpipe and inside of the tailpipe housing.

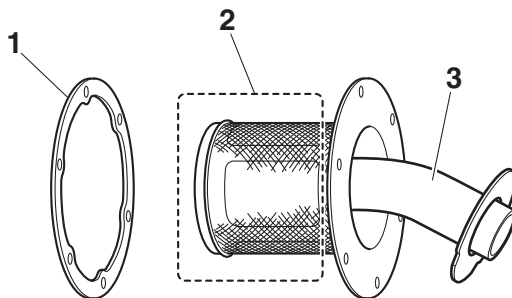

1. Gasket
2. Spark arrester
3. Tailpipe
5. Install the gasket, and then insert the tailpipe into the muffler and align the bolt holes.
6. Install the tailpipe bolts and tighten them to the specified torque.

Tightening torque:
Tailpipe bolt:
10 N·m (1.0 kgf·m, 7.4 lb·ft)

7. Install the tailpipe cover.

8. Install the tailpipe cover bolts and tighten them to the specified torque.

Tightening torque:

Tailpipe cover bolt:

8 N·m (0.8 kgf·m, 5.9 lb·ft)

EBU32460

Valve clearance

The correct valve clearance changes with use, resulting in improper fuel/air supply or engine noise. To prevent this, the valve clearance must be adjusted regularly. This adjustment however, should be left to a professional Yamaha service technician.

9

EBU32470

Brakes

Replacement of brake components requires professional knowledge. Brake service should be performed by a Yamaha dealer.

EWB02572



Operating with improperly serviced or adjusted brakes could lead to a loss in braking ability and an accident.

EBU35150

Checking the front and rear brake pads

Check each brake pad for damage and measure the lining thickness. If a brake pad is damaged or if the lining thickness is less than 1.0 mm (0.04 in), have a Yamaha dealer replace the brake pads as a set.

The wheels need to be removed to check the brake pads. (See pages 9-57, 9-59 for wheel removal and installation procedures.)

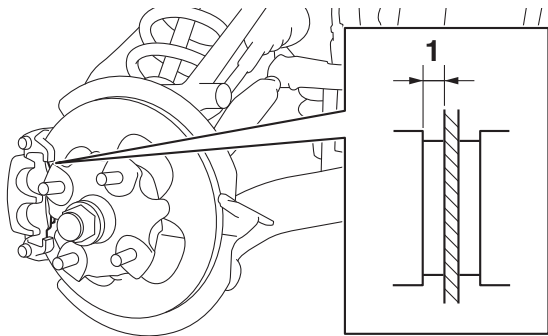

1. Lining thickness

EBU32490

Checking the parking brake pads

Each brake pad is provided with a wear indicator groove, which allows you to check the brake pad wear without having to disassemble the brake. If a brake pad has worn to the point that the wear indicator groove has almost disappeared, have a Yamaha dealer replace the brake pads as a set.

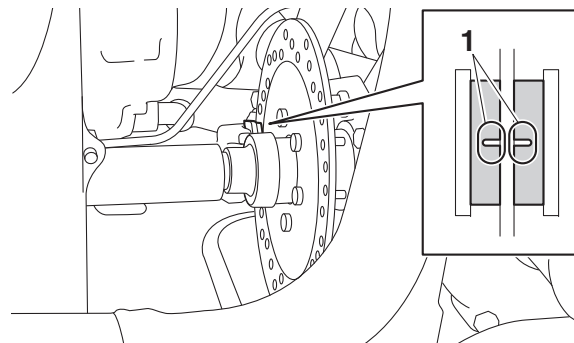

1. Parking brake pad wear indicator groove

EBU36610

Checking the brake and YCC-S clutch fluid levels

Before starting off, check that the brake and YCC-S clutch fluids are above the minimum level marks. Replenish the brake and YCC-S clutch fluids if necessary.

! WARNING

Improper maintenance can result in loss of braking ability or YCC-S clutch operation.

Observe these precautions:

- Insufficient brake or YCC-S clutch fluid may allow air to enter the brake or YCC-S clutch system, reducing braking or YCC-S clutch performance.
- Clean the filler caps before removing. Use only DOT 4 brake fluid from a sealed container.
- Use only the specified brake fluid; otherwise, the rubber seals may deteriorate, causing leakage.
- Refill with the same type of brake fluid. Adding a brake fluid other than DOT 4 may result in a harmful chemical reaction.

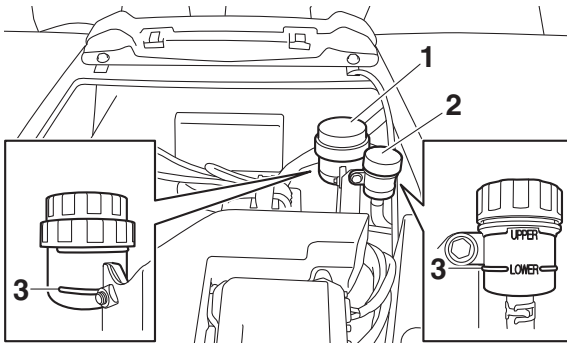

1. Brake fluid reservoir
2. YCC-S clutch fluid reservoir
3. Minimum level mark

TIP

- The brake and YCC-S clutch fluid reservoirs are located under the hood (page 9-11).
- For an accurate reading, make sure the vehicle is parked on a level surface.

Specified fluid for brake and YCC-S clutch systems:
DOT 4 brake fluid

- **Be careful that water or dust does not enter the brake or YCC-S clutch fluid reservoir when refilling. Water will significantly lower the boiling point of the fluid and may result in vapor lock.**

ECB01161

NOTICE

Brake fluid may damage painted surfaces or plastic parts. Always clean up spilled fluid immediately.

As the brake pads wear, it is normal for the brake fluid level to gradually go down. A low brake fluid level may indicate worn brake pads or brake system leakage; therefore, be sure to check the brake pads for wear and the brake system for leakage. A low YCC-S clutch fluid level may indicate YCC-S clutch system leakage; therefore, be sure to check the YCC-S clutch system for leakage. If the brake or YCC-S clutch fluid level goes down

suddenly, have a Yamaha dealer check and repair the vehicle before any further operation.

EBU36550

Brake and YCC-S clutch fluid replacement

Complete fluid replacement should be done only by trained Yamaha service personnel. Have a Yamaha dealer replace the following components during periodic maintenance or when they are damaged or leaking.

- Replace the oil seals every two years.
- Replace the brake and YCC-S clutch hoses every four years.

EBU36540

YCC-S clutch

This model is equipped with a hydraulic clutch, therefore, it is necessary to check the YCC-S clutch fluid level and check the hydraulic system for leakage before each drive. If the YCC-S clutch plates wear out, shifting becomes rough or clutch slippage will occur,

causing poor acceleration. If any of the above occurs, have a Yamaha dealer check the YCC-S clutch.

EBU32531

Checking the brake pedal

Have a Yamaha dealer check the brakes at the intervals specified in the periodic maintenance chart. There should be no free play in the brake pedal. The brakes should operate smoothly and there should be no brake drag. If the brakes feel soft or spongy, this could indicate air in the brake system. Have a Yamaha dealer check the brake system if necessary.

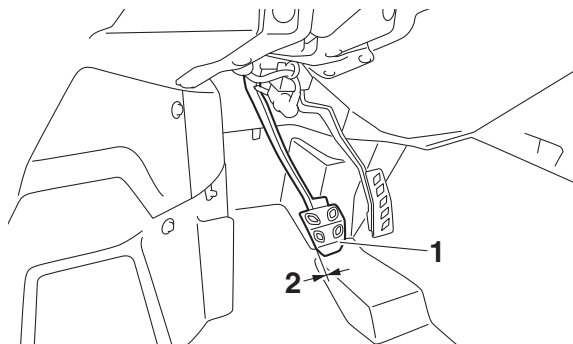

1. Brake pedal
2. No brake pedal free play

EBU35821

Checking the accelerator pedal

The accelerator pedal should operate smoothly and spring back to position when released. If the pedal free play is out of specification, have a Yamaha dealer adjust or replace the throttle wire.

Accelerator pedal free play:
10.0-25.0 mm (0.39-0.98 in)

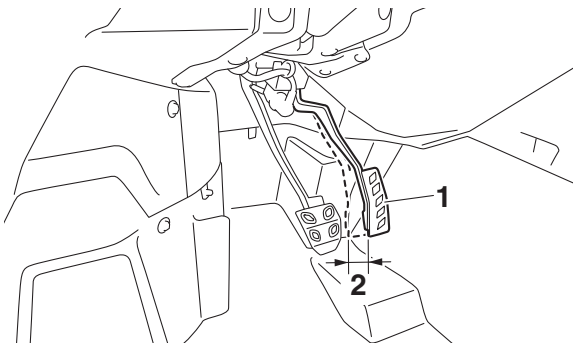

1. Accelerator pedal
2. Accelerator pedal free play

EBU35194

Parking brake lever free play adjustment

Periodically check the parking brake lever free play and adjust it if necessary.

1. Shift the transmission into first gear.
2. Check the parking brake lever free play.
The maximum free play is equal to one click of the parking brake lever. If necessary, adjust the free play as follows.

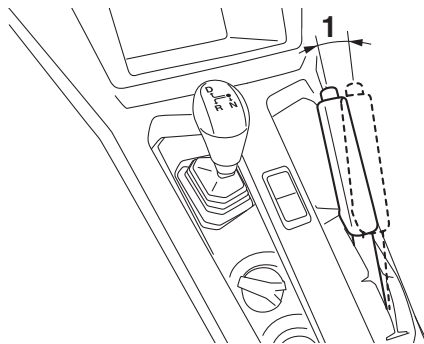

1. Parking brake lever free play
3. Remove panel B. (See page 9-11.)
4. Release the parking brake lever.
5. Slide the rubber cover back on the parking brake cable.
6. Loosen the locknut.

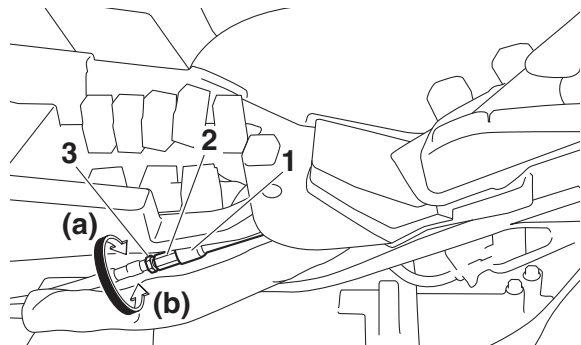

1. Rubber cover
2. Adjusting nut
3. Locknut

7. Turn the adjusting nut in direction (a) to increase the free play or in direction (b) to decrease the free play.
8. Tighten the locknut, and then slide the rubber cover to its original position.
9. Install the panel.

EBU36620

Brake light switch

The brake light, which is activated by the brake pedal, should come on just before braking takes effect. Since the brake light switch is a component of the YCC-S system, it must be adjusted by a Yamaha dealer, who has the necessary professional knowledge and experience.

EBU35930

Cable inspection and lubrication

EWB03380



Damaged cables could restrict operation, which may cause an accident or injury. Inspect control cables frequently and replace damaged cables. Corrosion can result when the outer covering of control cables becomes damaged. Cables can also become frayed or kinked.

Lubricate the cable ends. If the cables do not operate smoothly, ask a Yamaha dealer to replace them.

Recommended lubricant:
Yamalube LubezAll (synthetic lubricant spray with PTFE)

EBU36760

Pedal lubrication

The pivoting parts of the brake and accelerator pedals should be lubricated periodically to prevent rust and ensure smooth operation.

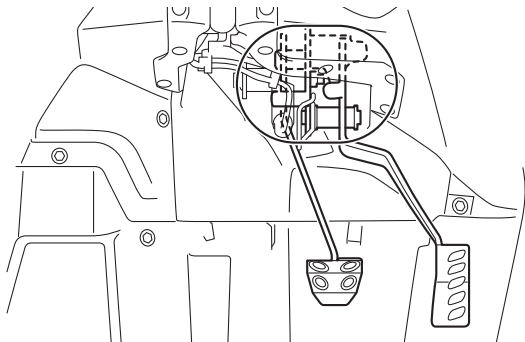

Recommended lubricant:
Lithium-soap-based grease

EBU32583

Checking the stabilizer bushes

The stabilizer bushes must be checked for cracks or damage at the intervals specified in the periodic maintenance chart. Have a Yamaha dealer replace the stabilizer bushes if necessary.

Front

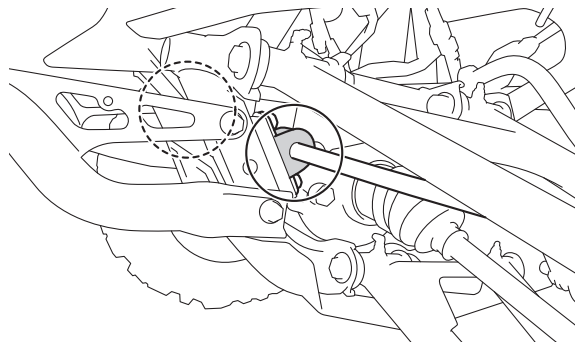

Rear

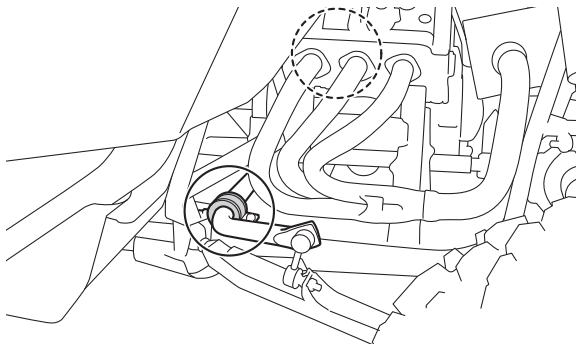

EBU35211

Upper and lower arm pivot lubrication (left and right)

Lubricate the upper and lower arm pivots with
a grease gun.

9

Front

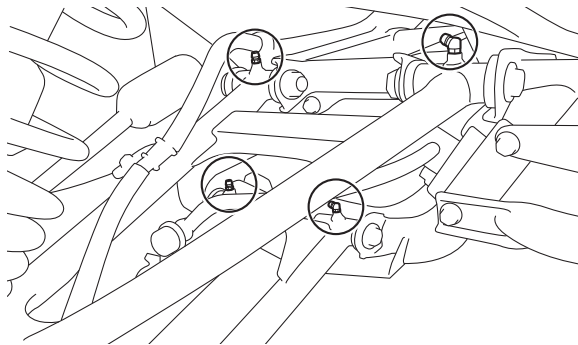

Rear

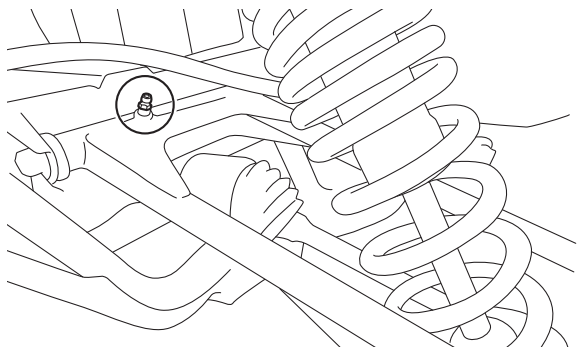

Recommended lubricant:
Lithium-soap-based grease

EBU32590

Rear knuckle upper and lower pivot lubrication (left and right)

Lubricate the knuckle upper and lower pivots with a grease gun.

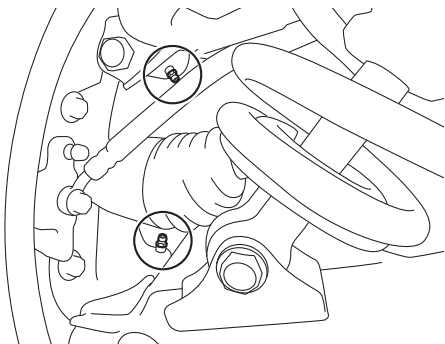

Recommended lubricant:
Lithium-soap-based grease

EBU35220

Drive shaft universal joint lubrication

Lubricate the drive shaft universal joint with a grease gun.

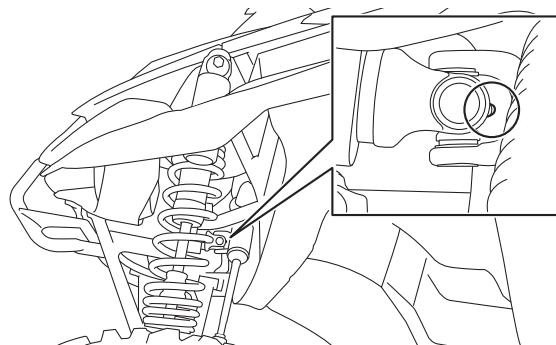

Recommended lubricant:
Lithium-soap-based grease

EBU32600

Steering shaft lubrication

Lubricate the pivot points.

Recommended lubricant:
Lithium-soap-based grease

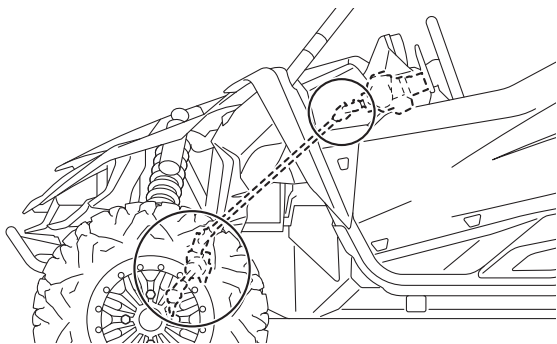

EBU32610

Wheel removal

1. Loosen the wheel nuts.
2. Elevate the vehicle and place a suitable stand under the frame.
3. Remove the nuts from the wheel.
4. Remove the wheel.

9

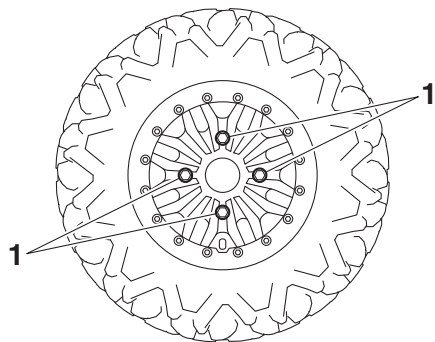

1. Wheel nut

EBU35833

Checking and tightening the bead lock (equipped models)

Check the bead lock at the intervals specified in the periodic maintenance chart and whenever the tires have been replaced.

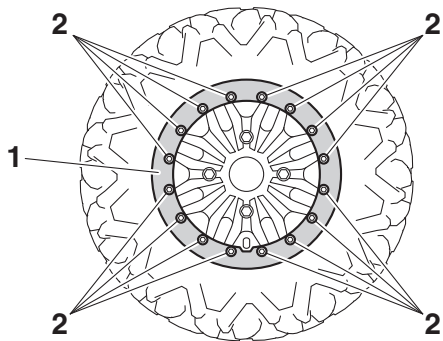

1. Bead lock
2. Bolt

Tighten the bead lock bolts to the specified torque in a crisscross pattern.

Tightening torque:
Bead lock bolts:
37 N·m (3.7 kgf·m, 27 lb·ft)

EBU32620

Tire replacement

Always use the same size and type of tires recommended in this owner's manual. The tires that came with your Yamaha

YXZ1000ET were designed to match the performance capabilities and to provide the best combination of handling, braking, and comfort. It is best to replace all four tires at the same time. If that is not possible, you must replace the tires in pairs (front or rear) with tires of the same size and type as the originals. Never replace just one tire.

EWB03390



WARNING

Installing improper tires on your Yamaha YXZ1000ET can affect handling and stability. This can cause a loss of control.

The tires listed below have been approved by Yamaha Motor Manufacturing Corporation of America for this model.

Front tire:

Size:

29 x 9.00R-14NHS

Manufacturer/model:

MAXXIS/M917 / BIGHORN

Rear tire:

Size:

29 x 11.00R-14NHS

Manufacturer/model:

MAXXIS/M918 / BIGHORN

Tightening torques:

Front wheel nut:

95 N·m (9.5 kgf·m, 70 lb·ft)

Rear wheel nut:

95 N·m (9.5 kgf·m, 70 lb·ft)

EBU35232

Battery

This model is equipped with a 12-volt VRLA (valve-regulated lead-acid) battery. There is no need to check the electrolyte or to add distilled water. However, the battery lead connections need to be checked and tightened, and the battery terminals cleaned if corroded. If the battery seems to have discharged, recharge it as soon as possible.

EWB03410



Avoid battery contact with skin, eyes, or clothing. Shield eyes when working near batteries. Keep out of reach of children. You could be poisoned or severely burned

EBU33090

Wheel installation

1. Install the wheel and the nuts.
2. Lower the vehicle so that the wheel is on the ground.
3. Tighten the wheel nuts in a crisscross pattern to the specified torque.

EWB03400



Do not reverse the rims on your Yamaha YXZ1000ET to widen the track width. Installing wheels improperly increases the risk of wheel failure and accidents.

by the sulfuric acid in battery electrolyte. In case of accidental contact with battery electrolyte:

EXTERNAL: Flush with water.

INTERNAL: Drink large quantities of water or milk. Follow with milk of magnesia, beaten egg, or vegetable oil. Get prompt medical attention.

EYES: Flush with water for 15 minutes and get prompt medical attention.

EWB03420

⚠ WARNING

Batteries may produce explosive gases. Ventilate when charging or using in a closed space. Keep batteries away from sparks, flames, cigarettes, or other sources of ignition.

To remove the battery

1. Turn the key to “⊙” (off).
2. Remove panel A. (See page 9-11.)

3. Remove the battery holding plate by removing the bolts.

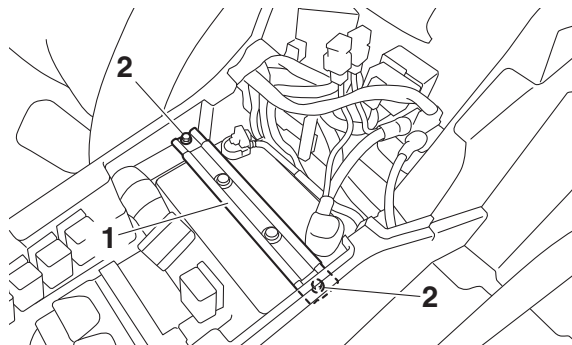

1. Battery holding plate

2. Bolt

4. Disconnect the negative battery lead first, then the positive battery lead by removing their bolt. **NOTICE: When removing the battery, the main switch must be off, and the negative lead must be disconnected before the positive lead.**

[ECB01002]

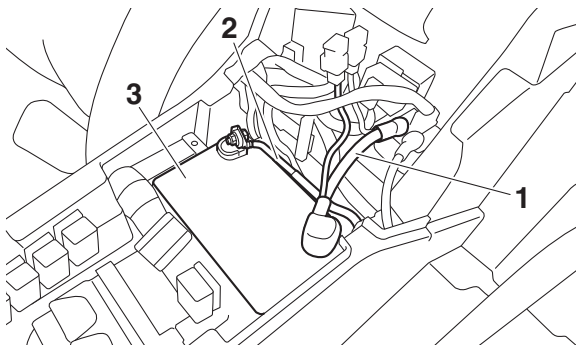

1. Positive battery lead (red)
2. Negative battery lead (black)
3. Battery

5. Pull the battery out of its compartment.

To charge the battery

9

- Remove it from vehicle and confirm the recommended charging rate as specified on the battery itself.
- Select a suitable charger and follow the manufacturer's instructions, or have a Yamaha dealer charge it for you.

- Keep in mind that the battery tends to discharge more quickly if the vehicle is equipped with optional electrical accessories.

ECB00933

NOTICE

To charge a VRLA (valve-regulated lead-acid) battery, a special battery charger is required. Using a conventional battery charger will damage the battery.

To store the battery

- If the vehicle will not be used for more than one month, remove the battery, fully charge it, and then place it in a cool, dry place.
- If the battery will be stored for more than two months, check it at least once a month and fully charge it if necessary.

NOTICE

- Always keep the battery charged. Storing the battery in a discharged state for an extended period of time will cause permanent battery damage.
- Do not store the battery in an excessively cold or warm place [below freezing or above 30 °C (90 °F)].

To install the battery**TIP**

Be sure the battery is fully charged.

1. Place the battery in its compartment.
2. Connect the positive battery lead first, then the negative battery lead by installing their bolt. **NOTICE: When installing the battery, the main switch must be off, and the positive lead must be connected before the negative lead.** [ECB01111]

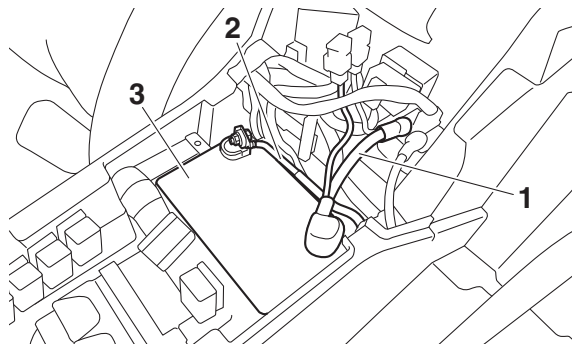

1. Positive battery lead (red)
2. Negative battery lead (black)
3. Battery

3. Install the battery holding plate by installing the bolts.
4. Install the panel.

TIP

- Make sure the battery leads are installed as shown.
- Fully charge the battery before installing it.

Jump-starting

Jump-starting the vehicle should be avoided. The battery should be removed and charged instead.

EWB03430

⚠ WARNING

To avoid battery explosion and/or serious damage to the electrical system:

- **Do not connect the negative lead of the jumper cable to the negative terminal of the battery.**
- **Do not touch the positive lead of the jumper cable to the negative lead.**
- **Do not reverse the polarity of the jumper cables when connecting to the batteries.**

9

However, if the vehicle must be jump-started, proceed as follows.

1. Turn the key to “○” (off).
2. Remove panel A. (See page 9-11.)
3. Remove the passenger seat cushion. (See page 5-26.)

4. Using a charged 12-volt battery, connect the positive lead of the jumper cable to the positive terminal of the battery in the YXZ1000ET and the other end of the positive lead to the positive terminal of the charged battery.

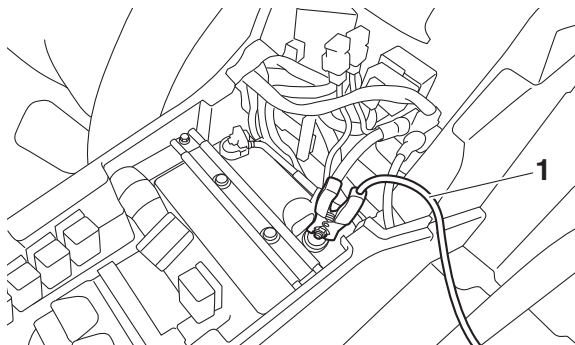

1. Jumper cable positive lead

5. Connect the negative lead of the jumper cable to the negative terminal of the charged battery and the other end of the negative lead to an unpainted metal surface of the passenger seat frame near the center console in the YXZ1000ET.

Fuse replacement

The main fuse, the fuel injection system fuse, the EPS fuse, and the fuse box are located under panel A. (See page 9-11.)

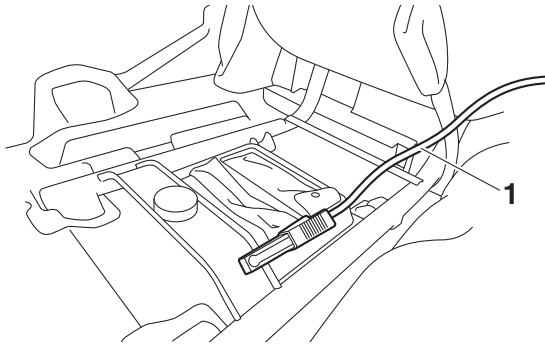

1. Jumper cable negative lead

6. Start the engine. (See page 7-2.)
7. After the engine starts, disconnect the negative lead of the jumper cable from the seat frame and charged battery, and then disconnect the positive lead of the jumper cable from the charged battery and the battery in the YXZ1000ET.
8. Install the seat cushion and the panel.

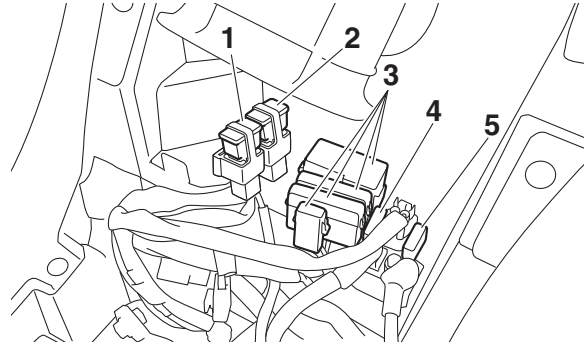

1. Main fuse
2. EPS fuse
3. Fuse box
4. Fuel injection system fuse
5. Fuel injection system spare fuse

NOTICE

To prevent accidental short-circuiting, turn off the main switch when checking or replacing a fuse.

2. Remove panel A. (See page 9-11.)
3. Remove the blown fuse, and then install a new fuse of the specified amperage.

WARNING! Always use a fuse of the specified amperage. Never use any material in place of the proper fuse. Using an improper fuse can cause damage to the electrical system and may lead to a fire. [EWB03440]

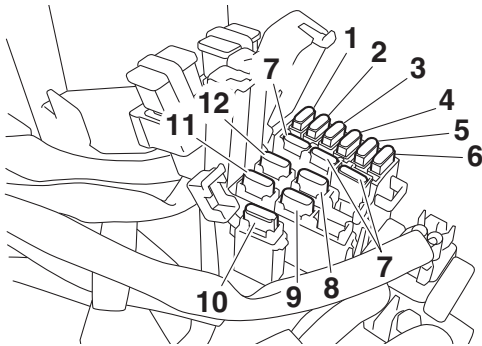

1. Headlight fuse "HEAD"
2. Signaling system fuse "SIGNAL"
3. Four-wheel-drive motor fuse "DIFF"
4. Ignition fuse "IGNITION"
5. Backup fuse "BACK UP" (for clock)
6. Radiator fan motor fuse "FAN"
7. Spare fuse
8. Accessory fuse "ACC"
9. YCC-S motor control fuse 2 "MOTOR_CONT_2"
10. Sub radiator fan motor fuse "FAN_2"
11. YCC-S motor control fuse 1 "MOTOR_CONT_1"
12. Auxiliary DC jack fuse "TERMINAL"

If a fuse is blown, replace it as follows.

1. Turn the key to "⊙" (off) and turn off the electrical circuit in question.

Specified fuses:

Main fuse:

50.0 A

Fuel injection system fuse:

15.0 A

Headlight fuse:

15.0 A

Ignition fuse:

15.0 A

Auxiliary DC jack fuse:

10.0 A

Signaling system fuse:

10.0 A

Four-wheel-drive motor fuse:

10.0 A

Sub radiator fan motor fuse:

30.0 A

Radiator fan motor fuse:

30.0 A

Backup fuse:

10.0 A

EPS fuse:

40.0 A

Accessory fuse:

15.0 A

YCC-S motor control fuse:

30.0 A

YCC-S motor control fuse_2:

30.0 A

4. Turn the key to “ I ” (on) and turn on the electrical circuit in question to check if the device operates. If the fuse blows again immediately, have a Yamaha dealer check the electrical system.
5. Install the panel.

EBU35261

Headlights

This model is equipped with LED headlights. There are no user replaceable bulbs. If one or more headlights do not come on, check for a loose connection, check the headlight fuse, and then have a Yamaha dealer check the vehicle.

TIP

- When the headlights are set to low beam, only the top half of each lamp will illuminate.

- When the headlights are set to high beam, both halves of each lamp will illuminate.

EBU32681

Headlight beam adjustment

ECB00691

NOTICE

It is advisable to have a Yamaha dealer make this adjustment.

To raise the beam, turn the headlight beam adjusting screw in direction (a).

To lower the beam, turn the headlight beam adjusting screw in direction (b).

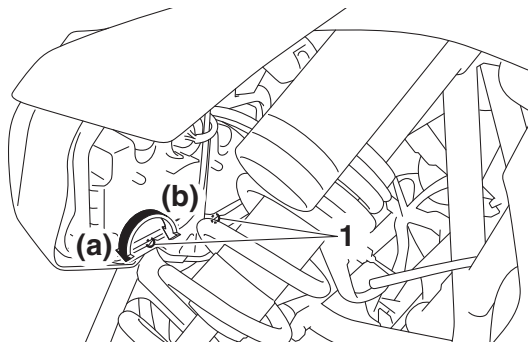

1. Headlight beam adjusting screw

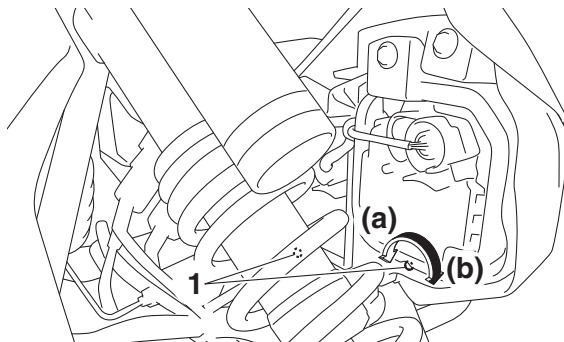

1. Headlight beam adjusting screw

EBU37910

Brake/tail light

This model is equipped with an LED brake/tail light, there are no replaceable bulbs.

If the brake/tail light does not come on, check for a loose connection, check the fuses, and then have a Yamaha dealer check the vehicle.

EBU36961

Interior lights (equipped models)

This model is equipped with LED interior lights. There are no user replaceable bulbs.

If one or more interior lights do not come on, check for a loose connection, check the fuses, and then have a Yamaha dealer check the vehicle.

EBU32700

Troubleshooting

Although Yamaha vehicles receive an inspection before shipment from the factory, trouble may occur during operation. Any problem in the fuel, compression, or ignition systems can cause poor starting and loss of power. The troubleshooting chart describes a quick, easy

procedure for making checks. If your vehicle requires any repair, take it to a Yamaha dealer.

The skilled technicians at a Yamaha dealership have the tools, experience, and know-how to properly service your vehicle. Use only genuine Yamaha parts on your vehicle. Imitation parts may look like Yamaha parts, but they are often inferior. Consequently, they have a shorter service life and can lead to expensive repair bills.

EWB03450



When checking the fuel system, do not smoke and make sure there are no open flames or sparks in the area, including pilot lights from water heaters or furnaces. Gasoline or gasoline vapors can ignite or explode, causing severe injury or property damage.

Troubleshooting charts

Starting problems or poor engine performance

1. Fuel

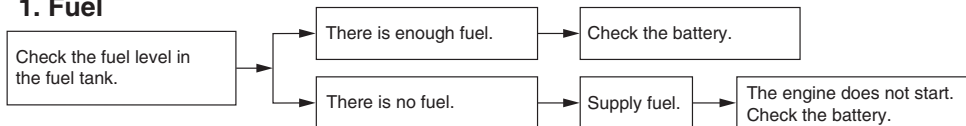

2. Battery

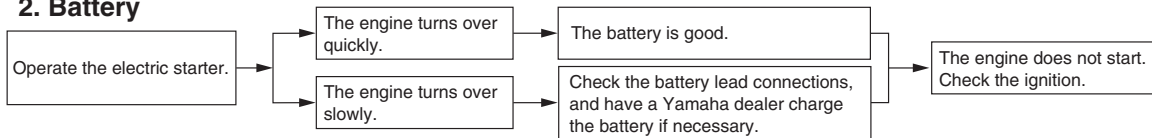

3. Ignition

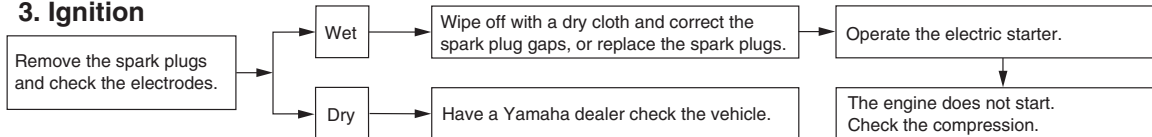

4. Compression

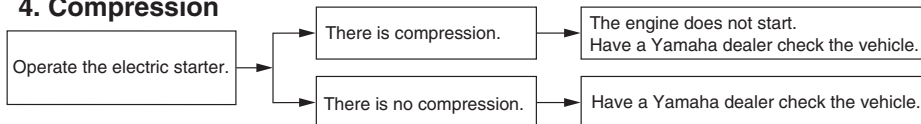

Engine overheating

Wait for the engine to cool before removing the radiator cap. **WARNING! If the engine is not cool when removing the radiator cap, hot fluid and steam could blow out under pressure and burn you.** [EWB03460] Place a thick rag over the cap and remove the cap slowly to allow any remaining pressure to escape.

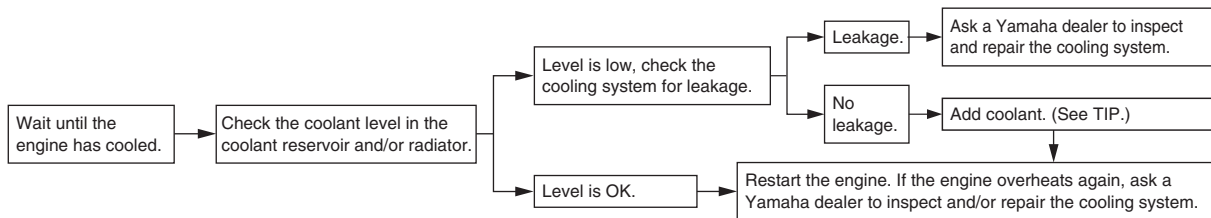

TIP

- Tap water can be used in an emergency. Change to the recommended coolant as soon as possible.
- The engine will tend to overheat if the radiator is caked with mud, or if air was not properly bled from the cooling system.

CLEANING AND STORAGE

Cleaning

Frequent, thorough cleaning of your vehicle will not only enhance its appearance but will improve its general performance and extend the useful life of many components.

1. Before cleaning the vehicle:
 - a. Block off the end of the exhaust pipe to prevent water entry. A plastic bag and strong rubber band may be used.
 - b. Make sure the spark plugs and all filler caps are properly installed.
2. If the engine case is excessively greasy, apply degreaser with a paint brush. Do not apply degreaser to the wheel axles.
3. Rinse the dirt and degreaser off with a garden hose. Use only enough pressure to do the job. **WARNING! Test the brakes after washing. Apply the brakes several times at slow speeds to let friction dry the brakes. Wet brakes**

may have reduced stopping ability, increasing the chance of an accident.

[EWB03471] **NOTICE: Excessive water pressure may cause water seepage and deterioration of wheel bearings, brakes, transmission seals and electrical devices. Many expensive repair bills have resulted from improper high-pressure detergent applications such as those available in coin-operated car washers.** [ECB00712]

4. Once the majority of the dirt has been hosed off, wash all surfaces with warm water and mild, detergent-type soap. An old toothbrush or bottle brush is handy for hard-to-get-at places.
5. Rinse the vehicle off immediately with clean water and dry all surfaces with a clean chamois towel or soft, absorbent cloth.
6. Clean the seats with a vinyl upholstery cleaner to keep the covers pliable and glossy.

7. Automotive-type wax may be applied to all painted and chrome-plated surfaces. Avoid combination cleaner-waxes. Many contain abrasives which may scratch the paint or protective finish. When finished, start the engine and let it idle for several minutes.

EBU32741

Storage

Long term storage (60 days or more) of your vehicle will require some preventive procedures to guard against deterioration. Make any necessary repairs before storing the vehicle.

After thoroughly cleaning the vehicle, prepare for storage as follows:

1. Fill the fuel tank with fresh fuel and add the specified amount of Fuel Med Rx or another high-quality fuel stabilizer product. Follow the instructions on the prod-

uct label. Operate the vehicle for at least 5 minutes to distribute treated fuel through the fuel system.

Specified amount:

1 oz of stabilizer to each gallon of fuel (or
7.5 ml of stabilizer to each liter of fuel)

2. Remove the spark plugs and pour one tablespoon of fresh engine oil into each cylinder and then re-install the spark plugs. Remove the spark plug wires and ground them. Operate the electric starter to turn the engine over several times and coat the cylinder walls with oil.
3. Lubricate all control cables.
4. Put the frame on stands or blocks to raise all wheels off the ground.
5. Tie a plastic bag over the exhaust pipe outlet to prevent moisture from entering.

6. If storing in a humid or salt-air atmosphere, coat all exposed metal surfaces with a light film of oil. Do not apply oil to any rubber parts or the seat covers.
7. Remove the battery and charge it. Store it in a dry place and recharge it once a month. Do not store the battery in an excessively warm or cold place [less than 0 °C (30 °F) or more than 30 °C (90 °F)].

Use of fuel stabilizer eliminates the need to drain the fuel system. Consult a Yamaha dealer if the fuel system needs to be drained.

SPECIFICATIONS

Dimensions:

- Overall length:
3147 mm (123.9 in)
- Overall width:
1626 mm (64.0 in)
- Overall height:
1751 mm (68.9 in)
- Wheelbase:
2300 mm (90.6 in)
- Ground clearance:
342 mm (13.5 in)
- Minimum turning radius:
6.0 m (19.69 ft)
- Maximum water depth:
40 cm (16 in)

Weight:

- Technical permissible mass (Maximum load + curb weight):
1065.0 kg (2348 lb)
- Curb weight:
691.0 kg (1523 lb) (BASFB)
709.0 kg (1563 lb) (BASCB)

Loading:

- Maximum load:
328.0 kg (723 lb)

(Total weight of operator, passenger, cargo, and accessories)

Noise and vibration level:

- Noise level (77/311/EEC):
83.0 dB(A) at 4250 r/min
- Uncertainty of measurement:
3.0 dB(A)
- A-weighted sound power level:
100.0 dB(A) at 4250 r/min
- Uncertainty of measurement:
3.0 dB(A)
- Vibration on seat (EN1032, ISO5008):
Will not exceed 0.5 m/s²
- Uncertainty of measurement:
0.1 m/s²
- Vibration on handle (EN1032, ISO5008):
Will not exceed 2.5 m/s²
- Uncertainty of measurement:
0.5 m/s²

Engine:

- Combustion cycle:
4-stroke
- Cooling system:
Liquid cooled
- Valve train:
DOHC
- Cylinder arrangement:
Inline

Number of cylinders:

3-cylinder

Displacement:

998 cm³

Bore × stroke:

80.0 × 66.2 mm (3.15 × 2.61 in)

Compression ratio:

11.3 : 1

Starting system:

Electric starter

Lubrication system:

Dry sump

Engine oil:

Recommended brand:



SAE viscosity grades:

5W-30, 10W-30, 10W-40, 15W-40, 20W-40, 20W-50

Recommended engine oil grade:

API service SG type or higher, JASO standard MA

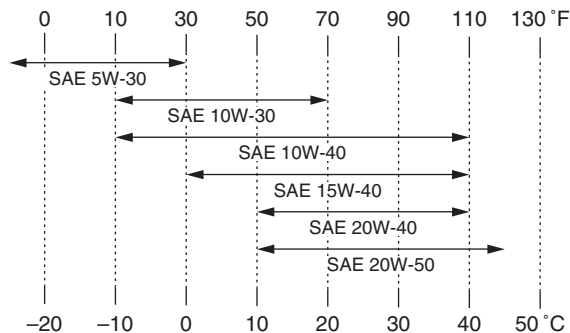

Quantity:

Oil change:

2.50 L (2.64 US qt, 2.20 Imp.qt)

With oil filter removal:

2.70 L (2.85 US qt, 2.38 Imp.qt)

Transmission oil:

Type:

SAE 5W-30, 10W-30, 10W-40, 15W-40, 20W-40 or 20W-50

Recommended transmission oil grade:

API service SE, SF, SG type or higher, JASO standard MA

Quantity:

1.50 L (1.59 US qt, 1.32 Imp.qt)

Final gear oil:

Type:

SAE 80W-90 API GL-5 Hypoid gear oil

Quantity:

0.47 L (0.50 US qt, 0.41 Imp.qt)

Differential gear oil:

Type:

SAE 80W-90 API GL-5 Hypoid gear oil

Quantity:

0.18 L (0.19 US qt, 0.16 Imp.qt)

Coolant quantity:

Coolant reservoir (up to the maximum level mark):

0.56 L (0.59 US qt, 0.49 Imp.qt)

Radiator (including all routes):

3.78 L (4.00 US qt, 3.33 Imp.qt)

Air filter:

Air filter element:

Wet element

Air filter oil grade:

Foam air-filter oil

Secondary air filter element:

Oil-coated paper element

Fuel:

Recommended fuel:

Regular unleaded gasoline (Gasohol [E10] acceptable)

Minimum research octane:

91

Fuel tank capacity:

34 L (9.0 US gal, 7.5 Imp.gal)

Fuel reserve amount:

8.5 L (2.24 US gal, 1.87 Imp.gal)

Throttle body:

ID mark:

B5H1

Spark plug (s):

Manufacturer/model:

NGK/CR9EB

Spark plug gap:

0.7–0.8 mm (0.028–0.031 in)

Drivetrain:

Primary reduction ratio:

1.660 (88/53)

Secondary reduction ratio:

7.333 (46/23 x 33/9)

Final drive:

Shaft

Clutch type:

Wet, multiple-disc

Transmission type:

5-speed with reverse

Gear ratio:

1st:

2.400 (36/15)

2nd:

1.545 (34/22)

3rd:

1.192 (31/26)

4th:

0.962 (25/26)

5th:

0.806 (25/31)

Reverse gear:

2.467 (28/15 x 37/28)

Front tire:

Size:

29 x 9.00R-14NHS

Manufacturer/model:

MAXXIS/M917 / BIGHORN

Rear tire:

Size:

29 x 11.00R-14NHS

Manufacturer/model:

MAXXIS/M918 / BIGHORN

Tire air pressure (measured on cold tires):

Vehicle load:

0.0–195.0 kg (0–430 lb)

Recommended:

Front:

114.0 kPa (1.140 kgf/cm², 16.5 psi)

Rear:

128.0 kPa (1.280 kgf/cm², 18.5 psi)

Minimum:

Front:

110.0 kPa (1.100 kgf/cm², 16.0 psi)

Rear:

124.0 kPa (1.240 kgf/cm², 18.0 psi)

Vehicle load:

195.0–328.0 kg (430–723 lb)

Recommended:

Front:

114.0 kPa (1.140 kgf/cm², 16.5 psi)

Rear:

169.0 kPa (1.690 kgf/cm², 24.5 psi)

Minimum:

Front:

110.0 kPa (1.100 kgf/cm², 16.0 psi)

Rear:

165.0 kPa (1.650 kgf/cm², 24.0 psi)**Front wheel:**

Rim size:

14 x 6.5 AT

Rear wheel:

Rim size:

14 x 8.0 AT

Front brake:

Type:

Hydraulic disc brake

Rear brake:

Type:

Hydraulic disc brake

Brake fluid:

Specified brake fluid:

DOT 4

Front suspension:

Type:

Double wishbone

Spring:

Coil spring

Shock absorber:

Gas-hydraulic damper

Wheel travel:

412 mm (16.3 in)

Rear suspension:

- Type:
 - Double wishbone
- Spring:
 - Coil spring
- Shock absorber:
 - Gas-hydraulic damper
- Wheel travel:
 - 432 mm (17.0 in)

Electrical system:

- System voltage:
 - 12 V
- Ignition system:
 - TCI
- Charging system:
 - AC magneto

Battery:

- Model:
 - U1-H11L
- Voltage, capacity:
 - 12 V, 28.0 Ah

Lights:

- Headlight:
 - LED
- Brake/tail light:
 - LED
- Interior light:
 - LED (BASC)
- Meter lighting:
 - LED

- Neutral indicator light:
 - LED
- High beam indicator light:
 - LED
- Reverse indicator light:
 - LED
- Coolant temperature warning light:
 - LED
- Parking brake indicator light:
 - LED
- Engine trouble warning light:
 - LED
- Differential gear lock indicator light:
 - LED
- EPS warning light:
 - LED
- Helmet reminder light:
 - 0.8 W
- Seat belt reminder light:
 - 0.8 W
- Shift timing indicator light:
 - LED
- Half clutch indicator light:
 - LED
- Launch system indicator light:
 - LED
- YCC-S system warning light:
 - LED

Fuses:

- Main fuse:
 - 50.0 A

Fuel injection system fuse:
15.0 A

EPS fuse:
40.0 A

Headlight fuse:
15.0 A

Signaling system fuse:
10.0 A

Ignition fuse:
15.0 A

Auxiliary DC jack fuse:
10.0 A

Accessory fuse:
15.0 A

YCC-S motor control fuse:
30.0 A

YCC-S motor control fuse_2:
30.0 A

Backup fuse:
10.0 A

Four-wheel-drive motor fuse:
10.0 A

Radiator fan motor fuse:
30.0 A

Sub radiator fan motor fuse:
30.0 A

The figures quoted are emission levels and are not necessarily safe working levels. Whilst there is a correlation between the emission and exposure levels, this cannot be used reliably to determine whether or not further precautions are required. Factors that influence the actual level of exposure of work-force include the characteristics of the work room, the other sources of noise, etc. i.e. the number of machines and other adjacent processes, and the length of time for which an operator is exposed to the noise. Also the permissible exposure level can vary from country. This information, however, will enable the user of the machine to make a better evaluation of the hazard and risk.

CONSUMER INFORMATION

EBU38330

Vehicle data recording

This model's control unit(s) store certain vehicle data to assist in the diagnosis of malfunctions and for research, statistical analysis and development purposes.

Although the sensors and recorded data will vary by model, the main data points are:

- Vehicle status and engine performance data
- Fuel-injection and emission-related data

This data will be uploaded only when a special Yamaha diagnostic tool is attached to the vehicle, such as when maintenance checks or service procedures are performed.

Vehicle data uploaded will be handled appropriately according to the following Privacy Policy.

Privacy Policy

<https://www.yamaha-motor.eu/eu/privacy/privacy-policy.aspx>

Yamaha will not disclose this data to a third party except in the following cases. In addition, Yamaha may provide vehicle data to a contractor in order to outsource services related to the handling of vehicle data. Even in this case, Yamaha will require the contractor to properly handle the vehicle data we provided and Yamaha will appropriately manage the data.

- With the consent of the vehicle owner
- Where obligated by law
- For use by Yamaha in litigation
- When the data is not related to an individual vehicle nor owner

INDEX

A

Accelerator pedal	5-22
Accelerator pedal, checking	9-51
Accelerator pedal, Pre-operation check	6-6
Air filter	9-40
Air filter case hoses, cleaning	9-44
Auxiliary DC jack	5-48
Axle boots	9-38

B

Basic guide for safe use	8-1
Battery, Periodic maintenance	9-59
Bead lock, checking and tightening (equipped models)	9-57
Brake and YCC-S clutch fluid levels, checking	9-48
Brake fluid, replacing	9-50
Brake light switch	9-53
Brake pedal	5-22
Brake pedal, checking	9-51
Brakes, Periodic maintenance	9-47
Brakes, Pre-operation check	6-3
Brake/tail light	9-68

C

Cable, inspecting and lubrication	9-53
Cargo bed	5-32
Cleaning	10-1
Control cables, Pre-operation check	6-8
Coolant, Periodic maintenance	9-36
Coolant, Pre-operation check	6-6
Coolant temperature warning light	5-4

Cup holders	5-31
-------------------	------

D

Data recording, vehicle	12-1
Differential gear lock indicator light	5-3
Differential gear oil, Periodic maintenance	9-34
Differential gear, Pre-operation check	6-6
Doors	5-25
Drive mode, selecting	7-10
Driver seat position	5-27
Drive select lever and shift paddles	5-24
Drive select lever and shift paddles, Pre-operation check	6-7
Drive shaft universal joint, lubrication	9-56
Drivetrain icon	5-3
Dynamic clutch engagement	7-7

E

Engine break-in	7-1
Engine oil and oil filter, Periodic maintenance	9-18
Engine oil, Pre-operation check	6-5
Engine trouble warning light	5-5
EPS warning light	5-5

F

Final gear oil, Periodic maintenance	9-31
Final gear, Pre-operation check	6-6
Fittings and fasteners, Pre-operation check	6-8
Flag pole bracket	5-33
Four-wheel drive knob (On-Command 4WD)	5-21
Front and rear brake pads, checking	9-47
Fuel, Pre-operation check	6-3
Fuel tank cap	5-25
Fuse, replacing	9-64

G	Glove compartment	5-30
H	Half clutch indicator light	5-6
	Headlight beam, adjusting	9-67
	Headlights	9-66
	Helmet reminder light	5-9
	High beam indicator light	5-3
	Hood	9-11
I	Identification numbers	1-1
	Indicator lights and warning lights	5-2
	Instruments, lights and switches, Pre-operation check	6-8
	Interior lights (equipped models)	9-68
	Interior light switch (equipped models)	5-20
J	Jump-starting	9-63
L	Label locations	2-1
	Launch system indicator light	5-7
	Launch system operation	7-7
	Light switch	5-19
	Loading	7-12
M	Main switch	5-1
	Maintenance and lubrication chart	9-6
	Maintenance chart, emission control system	9-4
	Maintenance charts	9-4
	Model label	1-1
	Multi-function meter unit	5-10
N	Neutral indicator light	5-2
O	Owner's Manual and tool kit	9-2
P	Panels	9-11
	Parking	7-12
	Parking brake indicator light	5-3
	Parking brake lever	5-23
	Parking brake lever free play, adjusting	9-52
	Parking brake pads, checking	9-48
	Passenger handhold, Pre-operation check	6-7
	Pedal, lubrication	9-54
R	Rear knuckle upper and lower pivot, lubrication	9-56
	Rearview mirror (equipped models)	5-29
	Reverse indicator light	5-2
S	Safety information	3-1
	Seat belt reminder light	5-9
	Seat belts	5-29
	Seat belts, Pre-operation check	6-7
	Seats	5-26
	Shifting and reverse driving	7-3
	Shift light	5-4
	Shock absorbers, front	5-33
	Shock absorbers, rear	5-41
	Spark arrester, cleaning	9-45
	Spark plugs, checking	9-38
	Specifications	11-1
	Stabilizer bushes, checking	9-54

Starting the engine	7-2
Steering, Pre-operation check	6-7
Steering shaft, lubrication	9-56
Steering wheel position	5-28
Storage	10-2
Storage compartments	5-30
T	
Tire, replacing	9-58
Tires, Pre-operation check	6-8
Transmission oil	9-29
Transmission, Pre-operation check	6-6
Troubleshooting	9-68
Troubleshooting charts	9-69
U	
Upper and lower arm pivot, lubrication	9-55
V	
Valve clearance	9-47
Vehicle identification number	1-1
W	
Wheel installation	9-59
Wheel removal	9-57
Y	
Yamalube	9-28
YCC-S clutch	9-50
YCC-S clutch, Pre-operation check	6-8
YCC-S system	5-23
YCC-S system warning light	5-7

Original instructions



PRINTED IN USA
2020.11-0.3x1 CR (E)